



Main

Range of Product	Modicon M340 automation platform
Product or Component Type	Counter module
Number of Channels	8
Maximum counting frequency	10000 Hz
Number of inputs	2 single mode) 3 special dual phase mode)
Input compatibility	19.2...30 V 2-wire/3-wire proximity sensor Incremental encoder with push-pull outputs, 10...30 V totem pole
Input voltage	24 V DC type 3

Complementary

Counter functions	Up/Down counter 32-bit counter counting Frequency meter Loop (modulo) counting Count events Down counting
Cycle time	5 ms
Isolation voltage	1500 V 60 s
Input type	High speed
Input voltage limits	30 V
Input current	2 mA at 11 V
Voltage state 1 guaranteed	11...30 V
Current state 1 guaranteed	>= 6 mA
Voltage state 0 guaranteed	< 5 V
Current state 0 guaranteed	<= 1.5 mA
Electrical connection	1 connector 20 pins
Current consumption	200 mA 3.3 V DC bus 80 mA 24 V DC sensor
Module format	Standard
Net Weight	0.25 lb(US) (0.113 kg)

Environment

Ambient Air Temperature for Operation	32...140 °F (0...60 °C)
Relative Humidity	10...95 % without condensation
IP Degree of Protection	IP20
Directives	2014/35/EU - low voltage directive 2014/30/EU - electromagnetic compatibility
Protective treatment	TC

Ordering and shipping details

Category	18160-MODICON M340
Discount Schedule	PC34
GTIN	3595863910131
Returnability	Yes
Country of origin	FR

Packing Units

Unit Type of Package 1	PCE
Number of Units in Package 1	1
Package 1 Height	2.05 in (5.2 cm)
Package 1 Width	4.33 in (11.0 cm)
Package 1 Length	4.65 in (11.8 cm)
Package 1 Weight	5.04 oz (143.0 g)
Unit Type of Package 2	S02
Number of Units in Package 2	15
Package 2 Height	5.91 in (15.0 cm)
Package 2 Width	11.81 in (30.0 cm)
Package 2 Length	15.75 in (40.0 cm)
Package 2 Weight	5.27 lb(US) (2.39 kg)

Offer Sustainability

California proposition 65	WARNING: This product can expose you to chemicals including: Lead and lead compounds, which is known to the State of California to cause cancer and birth defects or other reproductive harm. For more information go to www.P65Warnings.ca.gov
REACH Regulation	REACH Declaration
EU RoHS Directive	Pro-active compliance (Product out of EU RoHS legal scope)
Mercury free	Yes
China RoHS Regulation	China RoHS Declaration
RoHS exemption information	Yes
WEEE	The product must be disposed on European Union markets following specific waste collection and never end up in rubbish bins.

Contractual warranty

Warranty	18 months
----------	-----------

Modules Mounted on Racks

Dimensions



(1) With removable terminal block (cage, screw or spring).

(2) With FCN connector.

(3) On AM1 ED rail: 35 mm wide, 15 mm deep. Only possible with BMXXBP0400/0400H/0600/0600H/0800/0800H rack.

Rack references	a in mm	a in in.
BMXXBP0400 and BMXXBP0400H	242.4	09.54
BMXXBP0600 and BMXXBP0600H	307.6	12.11
BMXXBP0800 and BMXXBP0800H	372.8	14.68
BMXXBP1200 and BMXXBP1200H	503.2	19.81

Counting Module Wiring

Pin Assignments

IN_A input for channel 0	2	1	IN_AUX input for channel 0
IN_A input for channel 1 or IN_B input for channel 0	4	3	IN_AUX input for channel 1
IN_A input for channel 2	6	5	IN_AUX input for channel 2
IN_A input for channel 3 or IN_B input for channel 2	8	7	IN_AUX input for channel 3
IN_A input for channel 4	10	9	IN_AUX input for channel 4
IN_A input for channel 5 or IN_B input for channel 4	12	11	IN_AUX input for channel 5
IN_A input for channel 6	14	13	IN_AUX input for channel 6
IN_A input for channel 7 or IN_B input for channel 6	16	15	IN_AUX input for channel 7
VDC + power supply for sensors	18	17	Return + 24 V power supply for sensors
Functional earth, for shield continuation	20	19	Functional earth, for shield continuation

Sensor Connection Example

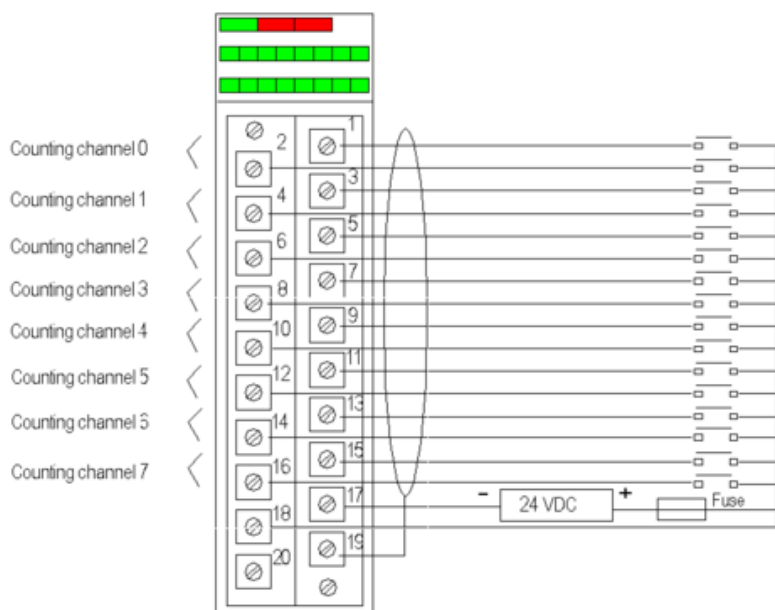

Incremental Encoder Connection Example for Axis Control

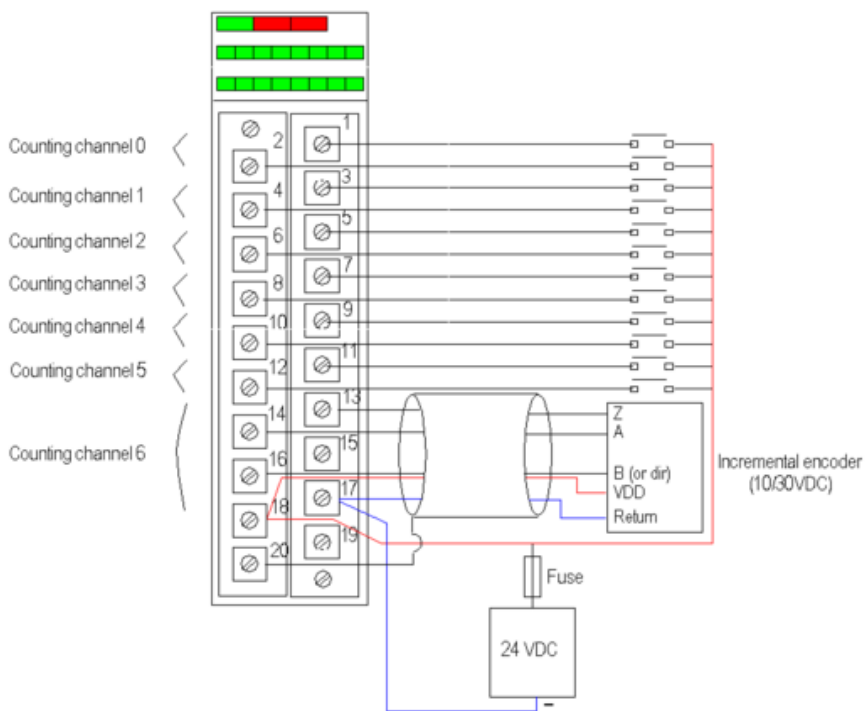

Channels 0 to 5 are still used in single mode.
 Channel 7 is no longer available.

Recommended Circuit for a Highly Disturbed Environment Using BMXXSP... Electromagnetic Protection Kit

