

XB5S2B2L2

Biometric switch monostable, Harmony XB5S, plastic, 22mm, connection by 2m cable, 24V AC DC



Main

Product or Component Type	Biometric switch
Product Specific Application	Industrial machines Materials handling
Device short name	XB5S
Bezel material	Dark grey plastic
Mounting diameter	0.87 in (22 mm)
Output Type	PNP
Sale per indivisible quantity	1
IP degree of protection	IP20 EN/IEC 60529 rear face) IP65 EN/IEC 60529 front face)
Type of operator	Momentary
Operator profile	Fingerprint reader
Connections - terminals	1 pre-wired cable, 3 x 0.34 mm ²
Memory usage	200 users with up to 2 fingerprints per user

Complementary

Enclosure Material	Polyamide PA66
Cable insulation material	PvR
Operating position	Flat surface installation Horizontal position Vertical surface installation
Function of module	Monostable
Net Weight	0.37 lb(US) (0.17 kg)
Marking	CE
Local signalling	For output state indicator 1 LED (green) For administrator's registration mode 1 LED (orange) For operator's registration mode 1 LED (orange) For error 1 LED (red) For reset 1 LED (red)
Short-circuit protection	250 mA external fuse gG
[Us] rated supply voltage	24 V DC
Electrical connection	Free wire ends 3 6.56 ft (2 m)
Supply voltage limits	20...30 V DC
Protection Type	Overload protection Short-circuit Reverse polarity
Maximum switching current	200 mA
[Ures] residual voltage	1 V closed state
Current consumption	<= 70 mA no-load
Maximum delay first up	3 s + 0.5 ms per user registered
Maximum delay recovery	1.5 s
Maximum delay response	1.5 s

The information provided in this documentation contains general descriptions and/or technical characteristics of the performance of the products contained herein. This documentation is not intended as a substitute for and is not to be used for determining suitability or reliability of these products for specific user applications. It is the duty of any such user or integrator to perform the appropriate and complete risk analysis, evaluation and testing of the products with respect to the relevant specific application or use thereof. Neither Schneider Electric Industries SAS nor any of its affiliates or subsidiaries shall be responsible or liable for misuse of the information contained herein.

Environment

Range of Product	Harmony XB5S
Ambient Air Temperature for Storage	-13...158 °F (-25...70 °C)
Ambient Air Temperature for Operation	23...122 °F (-5...50 °C)
NEMA degree of protection	NEMA 12
Standards	IEC 61000-6-4 IEC 61000-6-2
Product Certifications	UL[RETURN]CSA
Vibration resistance	+/- 3 mm 5...9 Hz)IEC 60068-2-6 1 gn 9...500 Hz)IEC 60068-2-6
Shock resistance	50 gn 11 ms IEC 60068-2-27

Ordering and shipping details

Category	22471-BIOMETRIC PUSHBUTTON DO NOT NEGOT.
Discount Schedule	I
GTIN	3606480061417
Returnability	Yes
Country of origin	FR

Packing Units

Unit Type of Package 1	PCE
Number of Units in Package 1	1
Package 1 Height	2.68 in (6.8 cm)
Package 1 Width	3.74 in (9.5 cm)
Package 1 Length	7.28 in (18.5 cm)
Package 1 Weight	7.09 oz (201.0 g)
Unit Type of Package 2	S03
Number of Units in Package 2	24
Package 2 Height	11.81 in (30.0 cm)
Package 2 Width	11.81 in (30.0 cm)
Package 2 Length	15.75 in (40.0 cm)
Package 2 Weight	11.70 lb(US) (5.306 kg)

Offer Sustainability

California proposition 65	WARNING: This product can expose you to chemicals including: Lead and lead compounds, which is known to the State of California to cause cancer and birth defects or other reproductive harm. For more information go to www.P65Warnings.ca.gov
REACH Regulation	REACH Declaration
EU RoHS Directive	Pro-active compliance (Product out of EU RoHS legal scope)
Mercury free	Yes
China RoHS Regulation	China RoHS Declaration
RoHS exemption information	Yes
Environmental Disclosure	Product Environmental Profile
WEEE	The product must be disposed on European Union markets following specific waste collection and never end up in rubbish bins.

Contractual warranty

Warranty	18 months
----------	-----------

Dimensions of Biometric Switches

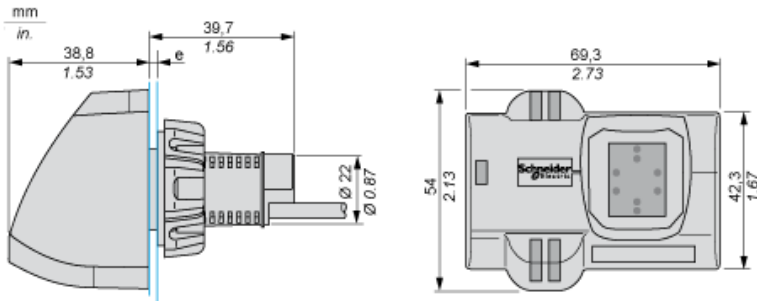

e: 1 to 6 mm / 0.04 to 0.24 in.

Cable with PNP Output

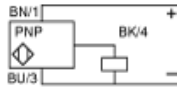

BU: Blue
BN: Brown
BK: Black