

# TM7BAM4VLA

Analog I/O expansion block, Modicon TM7,  
IP67, 2 AI/2AO, +/-10 V, M12 connector



## Main

Range of Product	Modicon TM7
Product or Component Type	Analog I/O expansion block
Range Compatibility	Modicon M258 Modicon LMC058
Enclosure Material	Plastic
Bus type	TM7 bus
[Ue] rated operational voltage	24 V DC
Input/output number	4
Input/output number of block	2 I + 2 O

## Complementary

Analogue input number	2
Analogue input type	Voltage
Analogue input range	+/- 10 V
Analogue input resolution	11 bits + sign
Analogue output number	2
Analogue output type	Voltage
Analogue output range	+/- 10 V
Sensor power supply	24 V, 500 mA for all channels overload, short-circuit and reverse polarity protection
Analogue output resolution	11 bits + sign
Electrical connection	1 male connector M12 - B coding - 4 ways bus IN 1 female connector M12 - B coding - 4 ways bus OUT 1 male connector M8 - 4 ways power IN 1 female connector M8 - 4 ways power OUT 4 female connectors M12 - A coding - 5 ways actuator
Local signalling	For bus diagnostic 2 LEDs For sensor/actuator power supply status 2 LEDs
Operating position	Any position
Fixing Mode	By 2 screws
Net Weight	0.44 lb(US) (0.2 kg)

## Environment

Standards	IEC 61131-2
Product Certifications	cURus[RETURN]GOST-R[RETURN]C-tick[RETURN]ATEX II 3g EEx nA II T5
Marking	CE
Ambient Air Temperature for Operation	14...140 °F (-10...60 °C)
Ambient Air Temperature for Storage	-13...185 °F (-25...85 °C)
Relative humidity	5...95 % without condensation or dripping water
Pollution degree	2 IEC 60664
IP degree of protection	IP67 conforming to IEC 61131-2
Operating altitude	0...6561.68 ft (0...2000 m)
Storage altitude	0.00...9842.52 ft (0...3000 m)
Vibration resistance	7.5 mm constant amplitude 2...8 Hz)IEC 60721-3-5 Class 5M3 2 gn constant acceleration 8...200 Hz)IEC 60721-3-5 Class 5M3 4 gn constant acceleration 200...500 Hz)IEC 60721-3-5 Class 5M3
Shock resistance	30 gn 11 ms IEC 60721-3-5 Class 5M3

Resistance to electrostatic discharge	6 KV in contact IEC 61000-4-2 8 kV in air IEC 61000-4-2
Resistance to electromagnetic fields	9.14 V/M (10 V/m) 0.08...2 Hz IEC 61000-4-3 0.91 V/m (1 V/m) 2...2.7 Hz IEC 61000-4-3
Resistance to fast transients	2 KV IEC 61000-4-4 (power supply) 1 KV IEC 61000-4-4 (input/output) 1 kV IEC 61000-4-4 (shielded cable)
Surge withstand for DC 24 V circuit	1 KV power supply (common mode) IEC 61000-4-5 0.5 KV power supply (differential mode) IEC 61000-4-5 1 KV unshielded links (common mode) IEC 61000-4-5 0.5 KV unshielded links (differential mode) IEC 61000-4-5 1 KV shielded links (common mode) IEC 61000-4-5 0.5 kV shielded links (differential mode) IEC 61000-4-5
Electromagnetic compatibility	EN/IEC 61000-4-6
Disturbance radiated/conducted	CISPR 11

## Ordering and shipping details

Category	22532-M258 PLC
Discount Schedule	PC12
GTIN	3595864093215
Returnability	No
Country of origin	AT

## Packing Units

Unit Type of Package 1	PCE
Number of Units in Package 1	1
Package 1 Height	1.97 in (5.000 cm)
Package 1 Width	2.36 in (6.000 cm)
Package 1 Length	4.33 in (11.000 cm)
Package 1 Weight	7.80 oz (221.000 g)
Unit Type of Package 2	S02
Number of Units in Package 2	24
Package 2 Height	5.91 in (15.000 cm)
Package 2 Width	11.81 in (30.000 cm)
Package 2 Length	15.75 in (40.000 cm)
Package 2 Weight	12.54 lb(US) (5.687 kg)

## Contractual warranty

Warranty	18 months
----------	-----------

Analog Mixed Block

Description

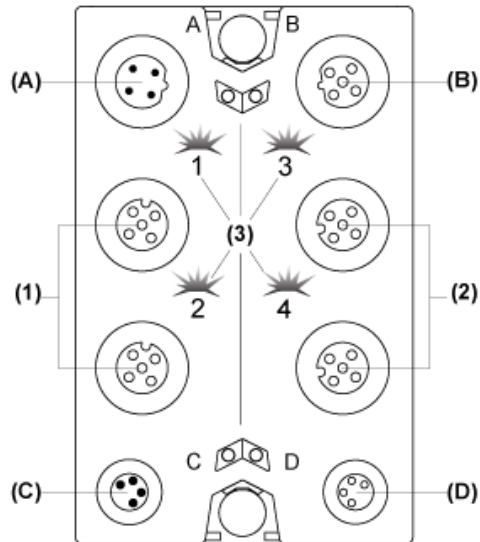

- (A) TM7 bus IN connector
- (B) TM7 bus OUT connector
- (C) 24 Vdc power IN connector
- (D) 24 Vdc power OUT connector
- (1) Input connectors
- (2) Output connectors
- (3) Status LEDs

Connector and Channel Assignments

I/O connectors	Channel type	Channels
1	Input	I0
2	Input	I1
3	Output	Q0
4	Output	Q1

## TM7 Block, Size 1

### Dimensions

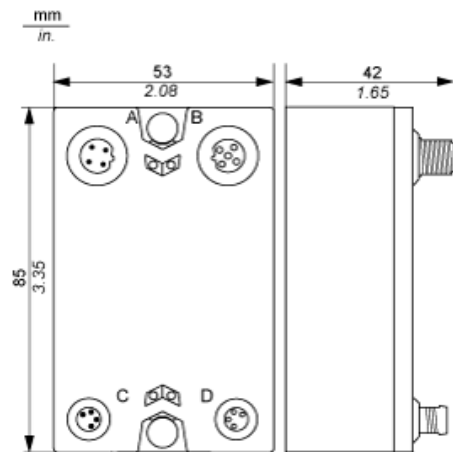

Spacing Requirements

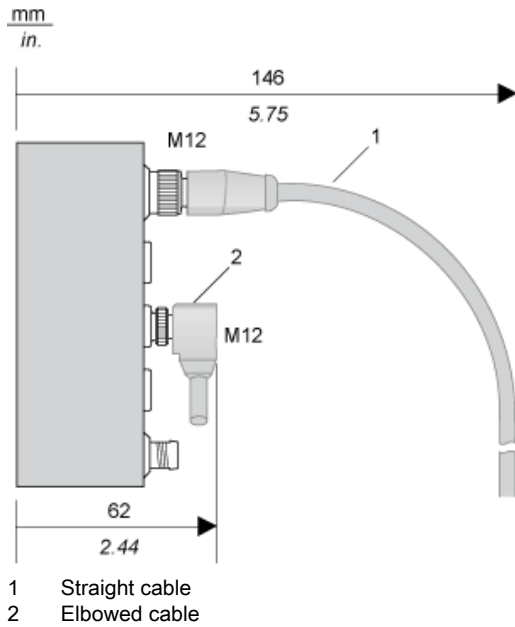

Installation Guidelines

TM7 Block on an Aluminium Frame

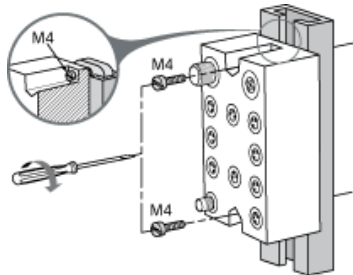

NOTE: Maximum torque to fasten the required M4 screws is 0.6 N.m (5.3 lbf-in).

TM7 Block on a DIN Rail

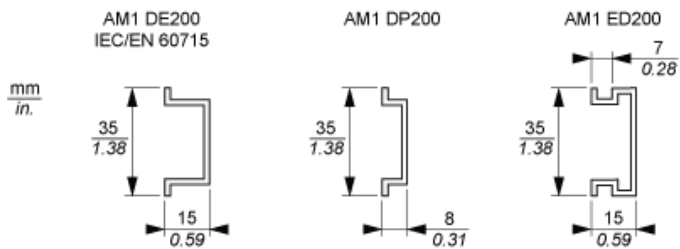

NOTE: Only size 1 (smallest) blocks can be installed on DIN rail with the TM7ACMP mounting plate.

## TM7 Block Directly on the Machine

Drilling template of the block:

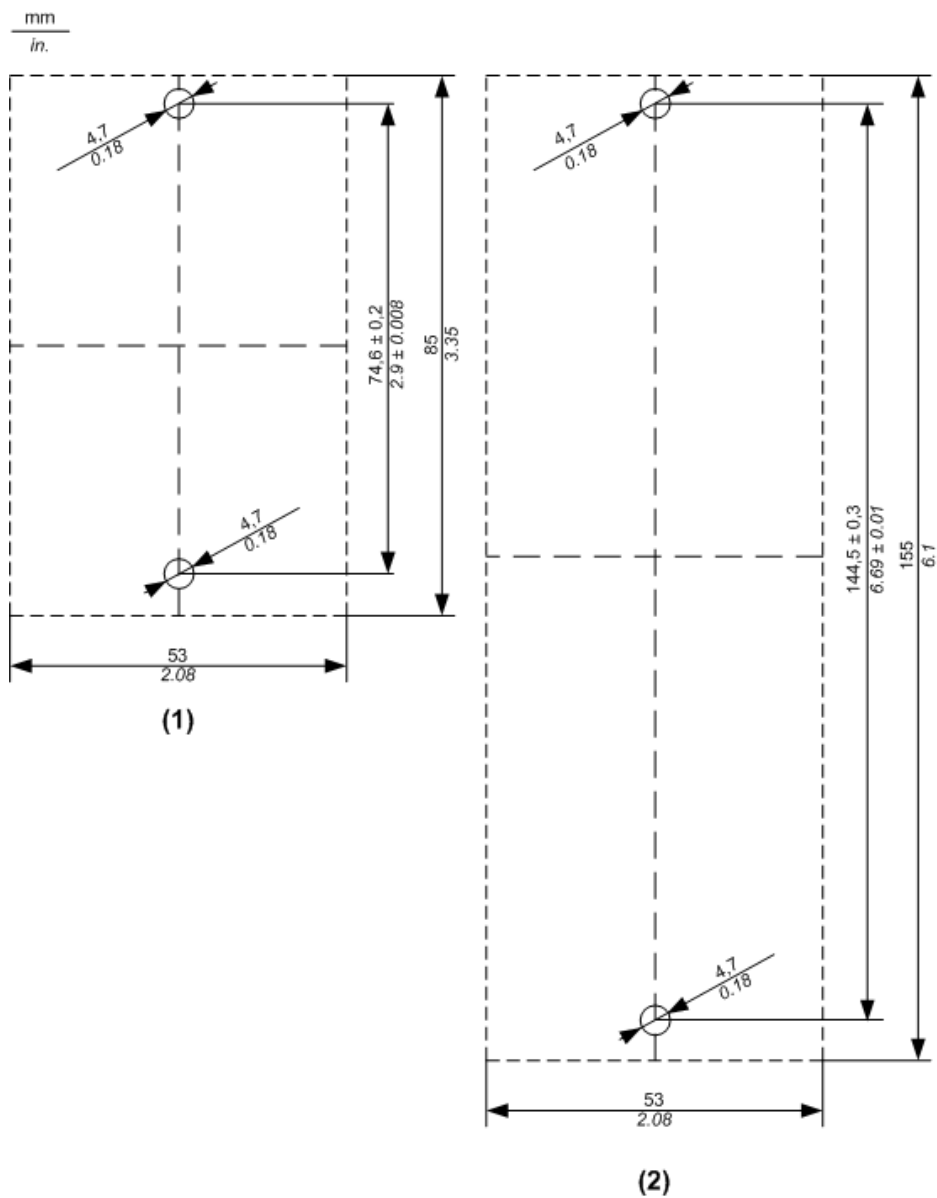

- (1) Size 1
- (2) Size 2

The thickness of the base plate should be taken into consideration when defining the screw length.

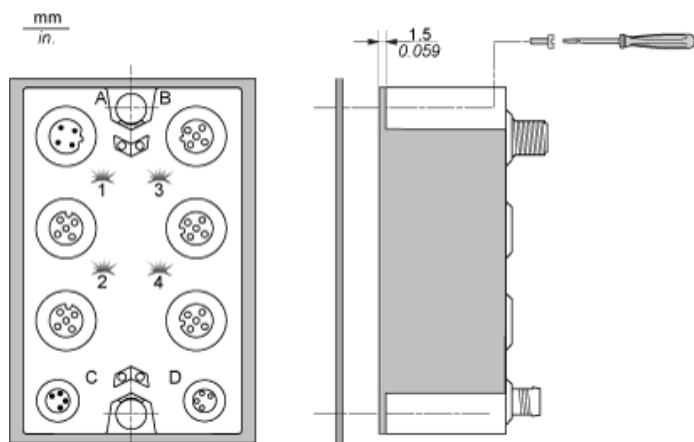

NOTE: Maximum torque to fasten the required M4 screws is 0.6 N.m (5.3 lbf-in).

Wiring Diagram

Pin Assignments for I/O Connectors

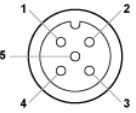
Connection	Pin	M12 Input	M12 Output
	1	24 Vdc sensor supply	Analog output +
2	Analog input +	24 Vdc actuator supply	
3	0 Vdc	Analog output - (0 Vdc)	
4	Analog input -	0 Vdc	
5	Shield	Shield	

Wiring the Power Supply

When you provide power to a TM7 I/O block using the 24 VDC Power OUT connector of the preceding I/O block, both blocks occupy the same 24 Vdc I/O power segment. However, if you connect an external isolated power supply to the 24 Vdc Power IN connector of a TM7 I/O block, you establish a new 24 Vdc I/O power segment beginning with that I/O block.

I/O block wired with one external 24 Vdc power supply:

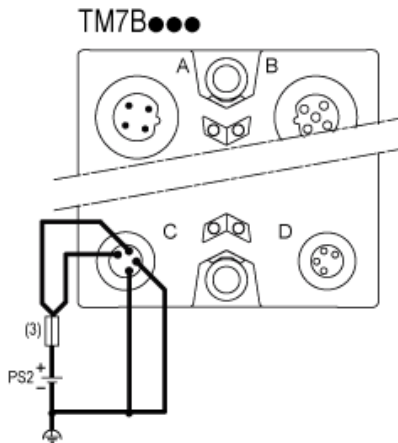

- (3) External fuse, Type T slow-blow, 8 A max., 250 V
- PS2 External isolated I/O power supply, 24 Vdc