



Main

Range of product	OsiSense XM
Product or component type	Electronic pressure sensors
Pressure sensor type	Pressure transmitter
Pressure sensor name	XMLP
Electrical circuit type	Control circuit
Pressure sensor size	1000 psi (6894.76 kPa)
Local display	Without
Controlled fluid	Fresh water 32...275 °F (0...135 °C) Air (-40...135 °C) Hydraulic oil (-40...135 °C) Gas (-40...135 °C) Refrigeration fluid (-40...135 °C)
Fluid connection type	1/4" - 18 NPT (male)
Electrical connection	1 male connector Packard Metripack 150 3 pins
[Us] rated supply voltage	24 V DC SELV (voltage limits: 12...33 V)
Current consumption	< 7 mA
Type of output signal	Analogue
Analogue output function	0...10 V, 3-wire
Quantity per set	Set of 1
Type of packing	Individual

Complementary

Pressure setting range	0...1000 psi (0.00...6894.76 kPa)
Maximum permissible accidental pressure	3000 psi (20684.27 kPa)
Destruction pressure	6000 psi (41368.54 kPa)
Materials in contact with fluid	Stainless steel AISI 316L
Operating position	Any position

Protection type	Reverse polarity Load short-circuit
Electromagnetic compatibility	Electrical fast transient/burst immunity test EN/IEC 61000-4-4 2 kV Electrostatic discharge immunity test EN/IEC 61000-4-2 8 kV air, 4 kV contact 1.2/50 µs shock waves immunity test EN/IEC 61000-4-5 1 kV 42 Ohm Immunity to magnetic fields EN/IEC 61000-4-8 100 A/m 50 Hz Susceptibility to electromagnetic fields EN/IEC 61000-4-3 10 V/m 80...3000 MHz Radiated RF fields EN/IEC 61000-4-6 10 V 0.01...80 MHz
[Uimp] rated impulse withstand voltage	0.5 kV
Response time on output	<= 2 ms 10...90 % of full scale
Measurement accuracy	+/- 0.5 % of the measuring range
Resolution	0.1 % of the measuring range
Drift of the sensitivity	+/- 0.02 % of measuring range/°K
Drift of the zero point	+/- 0.02 % of measuring range/°K
Mechanical durability	10000000 cycles
Net weight	0.20 lb(US) (0.09 kg)
Diameter	1.02 in (26 mm)
Length	2.17 in (55 mm)

Environment

Standards	EN/IEC 61326-2-3 NSF ANSI 61
Product certifications	RCM CE EAC CULus
Protective treatment	TC
Ambient air temperature for operation	-22...185 °F (-30...85 °C)
Ambient air temperature for storage	-58...212 °F (-50...100 °C)
Vibration resistance	20 gn 15...2000 Hz) EN/IEC 60068-2-6
Shock resistance	100 gn 11 ms EN/IEC 60068-2-27
IP degree of protection	IP65 conforming to EN/IEC 60529 IP67 EN/IEC 60529

Packing Units

Unit Type of Package 1	PCE
Number of Units in Package 1	1
Package 1 Weight	3.32 oz (94 g)
Package 1 Height	1.65 in (4.2 cm)
Package 1 width	1.85 in (4.7 cm)
Package 1 Length	3.43 in (8.7 cm)

Offer Sustainability

Sustainable offer status	Green Premium product
REACH Regulation	REACH Declaration
REACH free of SVHC	Yes
EU RoHS Directive	Pro-active compliance (Product out of EU RoHS legal scope) EU RoHS Declaration
Mercury free	Yes
RoHS exemption information	Yes
Environmental Disclosure	Product Environmental Profile

Dimensions

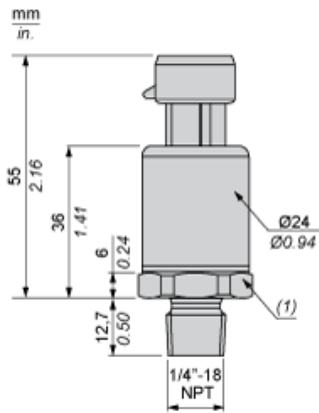

(1) SW24 tightening torque ≤ 25 N.m / 221 lb-in

Wiring Diagram

3-Wire Technique (0-10 V)

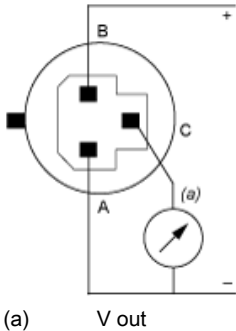

Curves

