

THREE-PHASE AUTOTRANSFORMERS

APPLICATION

Autotransformers are an economical and compact means of connecting electrical equipment to a power supply of a different voltage. Part of the winding is common to both primary and secondary circuits so there is no isolation between the two. This may not be acceptable on some power systems that do not have a grounded neutral on the secondary side of the main power transformer. Typical applications include motor loads of industrial machinery, electric heating, air conditioners, etc.

FEATURES

- Performs same function as an isolation transformer of same KVA and voltage rating without the isolation feature.
- Generally radiates less noise than equivalent isolation transformer.
- All terminals are clearly identified and easy to connect.
- May be used in either step-up or step down configuration.
- Low regulation; less than three percent.
- Class 220 insulation used throughout range.
- **CSA certified, File No. LR 34493.**
- **UL listed, File No. E108255.**
- General-purpose ventilated steel enclosure suitable for indoor location. After fabrication all metal is finished in ASA 61 grey power coating suitable for most industrial and commercial installations.
- Transformers in enclosures up to #7 may be readily hung on H-columns, walls, shelves or floor mounted to suit each installation. All units have lifting lugs, and removable top, front and rear panels for convenient access to the terminals.
- Transformers in enclosure #8 or larger are suitable for floor or platform mounting and complete with integral lifting lugs, and removable top, front, and rear panels for convenient access to the terminals.
- Transformer terminations rated below 330 Amps are supplied with suitable hardware and lugs for cable connection. Terminations above 330 Amps are supplied with terminal pads only.

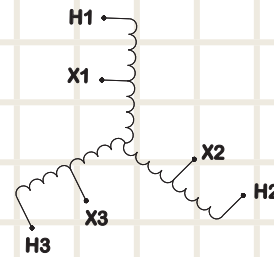

Typical configuration

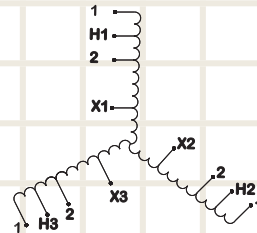

Optional configuration with $\pm 1x5\%$ taps



Notes:

- Other primary and secondary voltages available.
- Standard units do not have primary taps.
- Taps available on special order - refer to factory.
- Refer to factory for other frequencies.
- All enclosures listed are indoor type.
- Outdoor enclosures available - refer to factory.
- All dimensions are subject to change and should not be used for construction purposes. Certified drawings supplied upon request.
- Shipping weights are approximate. Actual weights may be higher due to packing and crating.
- Open type, core and coil transformers available, refer to factory.
- Neutral terminal is available as an optional feature.

THREE-PHASE AUTOTRANSFORMERS

PRI	SEC	KVA	CAT. NO.	TAPS	HZ	SIZE	Lb.	Kg.	PRI	SEC	KVA	CAT. NO.	TAPS	HZ	SIZE	Lb.	Kg.
600Y	480Y	3	RC3J-H	0	60	0	21	10	600Y	208Y	3	RC3J-B	0	60	1	45	21
		6	RC6J-H			1	34	16			6	RC6J-B			1	70	32
		9	RC9J-H			1	45	21			9	RC9J-B			3	130	59
		15	RC15J-H			1	65	29			15	RC15J-B			3	130	59
		30	RC30J-H			3	115	52			30	RC30J-B			5	210	95
		45	RC45J-H			3	135	61			45	RC45J-B			6	250	113
		75	RC75J-H			5	200	90			75	RC75J-B			6	360	163
		112.5	RC122J-H			6	225	102			112.5	RC122J-B			7	555	250
		150	RC150J-H			6	265	120			150	RC150J-B			8	650	293
		225	RC225J-H			7	450	175			225	RC225J-B			8	920	414
300	RC300J-H	7	525	237	300	RC300J-B	9	1330	599								
600Y	416Y	3	RC3J-G	0	60	0	32	15	480Y	240Y	3	RC3H-C	0	60	1	65	30
		6	RC6J-G			1	70	32			6	RC6H-C			1	85	39
		9	RC9J-G			1	85	39			9	RC9H-C			3	110	50
		15	RC15J-G			3	120	54			15	RC15H-C			3	125	57
		30	RC30J-G			3	135	61			30	RC30H-C			5	200	90
		45	RC45J-G			5	180	81			45	RC45H-C			5	225	102
		75	RC75J-G			6	225	102			75	RC75H-C			6	325	147
		112.5	RC122J-G			7	300	135			112.5	RC122H-C			7	450	203
		150	RC150J-G			8	400	180			150	RC150H-C			7	550	248
		225	RC225J-G			8	540	243			225	RC225H-C			8	675	304
300	RC300J-G	9	615	277	300	RC300H-C	8	900	405								
600Y	380Y	3	RC3J-F	0	60	1	38	18	480Y	208Y	3	RC3H-B	0	60	1	65	30
		6	RC6J-F			1	75	34			6	RC6H-B			1	85	39
		9	RC9J-F			3	110	50			9	RC9H-B			3	110	50
		15	RC15J-F			3	140	63			15	RC15H-B			3	130	59
		30	RC30J-F			5	170	77			30	RC30H-B			5	200	90
		45	RC45J-F			5	210	95			45	RC45H-B			5	225	102
		75	RC75J-F			6	285	129			75	RC75H-B			6	325	147
		112.5	RC122J-F			7	425	192			112.5	RC122H-B			7	450	203
		150	RC150J-F			8	525	237			150	RC150H-B			7	550	248
		225	RC225J-F			8	635	286			225	RC225H-B			8	675	304
300	RC300J-F	9	900	405	300	RC300H-B	8	900	405								
600Y	240Y	3	RC3J-C	0	60	1	40	18	240Y	208Y	3	RC3C-B	0	60	0	18	8
		6	RC6J-C			1	75	34			6	RC6C-B			0	21	10
		9	RC9J-C			3	120	54			9	RC9C-B			1	30	14
		15	RC15J-C			3	155	70			15	RC15C-B			1	52	24
		30	RC30J-C			5	225	99			30	RC30C-B			3	70	32
		45	RC45J-C			6	265	120			45	RC45C-B			3	125	57
		75	RC75J-C			6	400	181			75	RC75C-B			5	135	61
		112.5	RC122J-C			7	550	248			112.5	RC122C-B			5	180	81
		150	RC150J-C			7	610	277			150	RC150C-B			6	200	90
		225	RC225J-C			8	970	437			225	RC225C-B			6	240	108
300	RC300J-C	9	1300	585	300	RC300C-B	7	300	135								



REX POWER MAGNETICS

A DIVISION OF TRANSFACTOR INDUSTRIES INC.
65 BASALTIC RD, CONCORD, ON, CA L4K 1G4
TEL: 905-695-8844 • FAX: 905-695-8855
WWW.REXPOWERMAGNETICS.COM

TRANSFORMER SPECIFICATION

- 3 Phase Auto
- Dry Type
- ANN -Self cooled

Purchaser: TBA
 PO#: TBA
 SWO#: TBA
 Qty: TBA

Coils: Copper
 Cat. No.: RC45J-H
 kVA: 45
 Primary: 600 Volts
 Secondary: 480 Volts
 Frequency: 60 Hz
 Insulation Class: 200° C
 Temperature Rise: 130° C
 Weight: 135 Lbs

Termination	Location	Lug Size
Primary:	Front	2-14 AWG
Secondary:	Front	2-14 AWG

Wiring Connection:

Primary:
 Voltage 600
 Connect Lines To: H1-H2-H3

Secondary:
 Voltage 480
 Connect Loads To: X1-X2-X3

Preliminary Drawing ONLY

This drawing may NOT truly reflect our final design. Any resulting order(s) must be accompanied by or refer to this drawing and be marked with any proposed changes

Standards:

1. CSA Certified
 - File No. LR34493
2. UL Listed
 - File No. E108255

Standard Features:

1. Anti-vibration pads installed between the enclosure base and the core & coil assembly
2. Lug for Earth Grounding provided

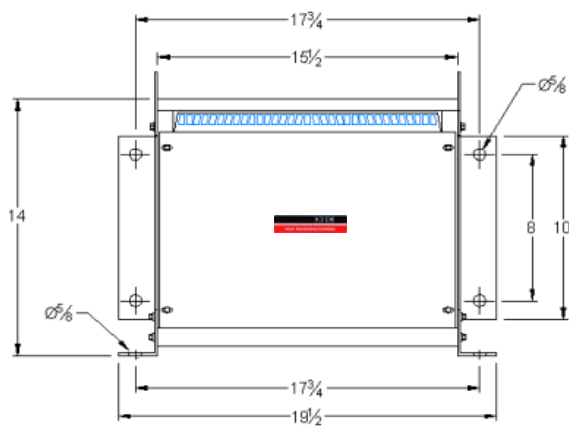
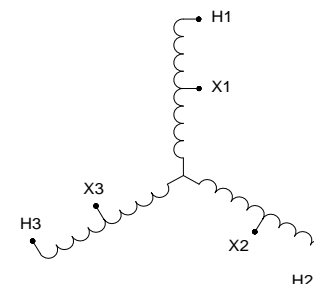

FRONT VIEW

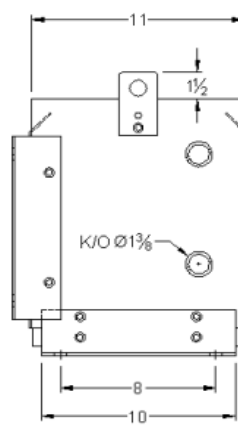

SIDE VIEW

CSA Enclosure:

- Type 1 (NEMA 1)
- Ventilated
- ASA 61 grey
- Floor/Wall mounting

Rev.	Remarks	By	Appr. By	Date

Prepared by: AP
 Approved by: VS
 Date: AUG.13, 2013
 X:\Drawings\WEB DWG\2013\3Ph\Auto\RC...J-H.xls