

# BMXDRC0805

discrete output module, Modicon X80, 8 NO or NC relay outputs, 24 to 240V AC, 24 to 125V DC



## Main

Range of Product	Modicon X80
Product or Component Type	Relay discrete output module
Discrete output number	8 EN/IEC 61131-2
Discrete output logic	Positive or negative
Discrete output voltage	5...125 V 5...150 V DC 24...240 V 19...264 V AC

## Complementary

Electrical connection	40 ways terminal block
Network Frequency	50/60 Hz
Network frequency limits	47...63 Hz
Sensor power supply	5...150 V 19...264 V
[Ith] conventional free air thermal current	4 A 104 °F (40 °C) 3 A 122 °F (50 °C) 2 A 140 °F (60 °C)
Insulation resistance	> 10 MOhm 500 V DC
Power dissipation in W	3.6 W
Response time on output	<= 10 ms activation <= 13 ms deactivation
Typical current consumption	40 MA 3.3 V DC 101 mA 24 V DC
MTBF reliability	2650000 H
Protection type	External short-circuit protection External overload protection External overvoltage protection, inductive AC External overvoltage protection, inductive DC
Output overload protection	Use 1 fast blow fuse per channel or group of channel
Output overvoltage protection	Use discharge diode on each output DC Use RC circuit on each output AC Use ZNO surge limiter on each output AC
Output short-circuit protection	Use 1 fast blow fuse per channel or group of channel
Minimum switching current	10 mA 5 V DC

The information provided in this documentation contains general descriptions and/or technical characteristics of the performance of the products contained herein. This documentation is not intended as a substitute for and is not to be used for determining suitability or reliability of these products for specific user applications. It is the duty of any such user or integrator to perform the appropriate and complete risk analysis, evaluation and testing of the products with respect to the relevant specific application or use thereof. Neither Schneider Electric Industries SAS nor any of its affiliates or subsidiaries shall be responsible or liable for misuse of the information contained herein.

Electrical durability	AC-12 200000 cycles 48 VA 24 V 32...140 °F (0...60 °C) AC-12 300000 cycles 48 VA 48 V 32...140 °F (0...60 °C) AC-12 150000 cycles 96 VA 48 V 32...140 °F (0...60 °C) AC-12 300000 cycles 110 VA 100...120 V 32...140 °F (0...60 °C) AC-12 150000 cycles 220 VA 100...120 V 32...140 °F (0...60 °C) AC-12 300000 cycles 220 VA 200...250 V 32...140 °F (0...60 °C) AC-12 150000 cycles 500 VA 200...250 V 32...140 °F (0...60 °C) AC-15 700000 cycles 10 VA 24 V 32...140 °F (0...60 °C) 0.4) AC-15 500000 cycles 24 VA 24 V 32...140 °F (0...60 °C) 0.4) AC-15 200000 cycles 48 VA 24 V 32...140 °F (0...60 °C) 0.4) AC-15 700000 cycles 10 VA 48 V 32...140 °F (0...60 °C) 0.4) AC-15 500000 cycles 24 VA 48 V 32...140 °F (0...60 °C) 0.4) AC-15 300000 cycles 48 VA 48 V 32...140 °F (0...60 °C) 0.4) AC-15 100000 cycles 96 VA 48 V 32...140 °F (0...60 °C) 0.4) AC-15 1000000 cycles 10 VA 100...120 V 32...140 °F (0...60 °C) 0.4) AC-15 300000 cycles 50 VA 100...120 V 32...140 °F (0...60 °C) 0.4) AC-15 200000 cycles 110 VA 100...120 V 32...140 °F (0...60 °C) 0.4) AC-15 70000 cycles 220 VA 100...120 V 32...140 °F (0...60 °C) 0.4) AC-15 1000000 cycles 10 VA 200...250 V 32...140 °F (0...60 °C) 0.4) AC-15 500000 cycles 50 VA 200...250 V 32...140 °F (0...60 °C) 0.4) AC-15 200000 cycles 110 VA 200...250 V 32...140 °F (0...60 °C) 0.4) AC-15 150000 cycles 220 VA 200...250 V 32...140 °F (0...60 °C) 0.4) DC-12 200000 cycles 24 W 24 V 32...140 °F (0...60 °C) DC-12 150000 cycles 48 W 24 V 32...140 °F (0...60 °C) DC-12 150000 cycles 40 W 48...60 V 32...140 °F (0...60 °C) DC-12 100000 cycles 45 W 100...125 V 32...140 °F (0...60 °C) DC-13 100000 cycles 10 W 24 V 32...140 °F (0...60 °C) DC-13 60000 cycles 24 W 24 V 32...140 °F (0...60 °C) DC-13 40000 cycles 48 W 24 V 32...140 °F (0...60 °C) DC-13 40000 cycles 40 W 48...60 V 32...140 °F (0...60 °C) DC-13 100000 cycles 15 W 100...125 V 32...140 °F (0...60 °C)
Status LED	1 LED (Green) RUN 1 LED per channel (Green) channel diagnostic 1 LED (Red) ERR 1 LED (Red) I/O
Net Weight	0.42 lb(US) (0.189 kg)

## Environment

IP Degree of Protection	IP20
Dielectric strength	1780 V AC 50/60 Hz 1 min
Vibration resistance	3 gn
Shock resistance	30 gn
Relative humidity	0...95 % 32...140 °F (0...60 °C) without condensation
Operating altitude	0...6561.68 ft (0...2000 m) 2000...5000 m with derating factor

## Ordering and shipping details

Category	18160-MODICON M340
Discount Schedule	PC34
GTIN	3606489485061
Returnability	Yes
Country of origin	FR

## Packing Units

Unit Type of Package 1	PCE
Number of Units in Package 1	1
Package 1 Height	2.17 in (5.500 cm)
Package 1 Width	7.09 in (18.000 cm)
Package 1 Length	10.24 in (26.000 cm)
Package 1 Weight	11.92 oz (338.000 g)
Unit Type of Package 2	S03
Number of Units in Package 2	8
Package 2 Height	11.81 in (30.000 cm)
Package 2 Width	11.81 in (30.000 cm)
Package 2 Length	15.75 in (40.000 cm)
Package 2 Weight	7.01 lb(US) (3.180 kg)

## Offer Sustainability

California proposition 65	WARNING: This product can expose you to chemicals including: Lead and lead compounds, which is known to the State of California to cause cancer and birth defects or other reproductive harm. For more information go to <a href="http://www.P65Warnings.ca.gov">www.P65Warnings.ca.gov</a>
REACH Regulation	<a href="#">REACH Declaration</a>
EU RoHS Directive	Pro-active compliance (Product out of EU RoHS legal scope)
Mercury free	Yes
China RoHS Regulation	<a href="#">China RoHS Declaration</a>
RoHS exemption information	<a href="#">Yes</a>
WEEE	The product must be disposed on European Union markets following specific waste collection and never end up in rubbish bins.

Dimensions

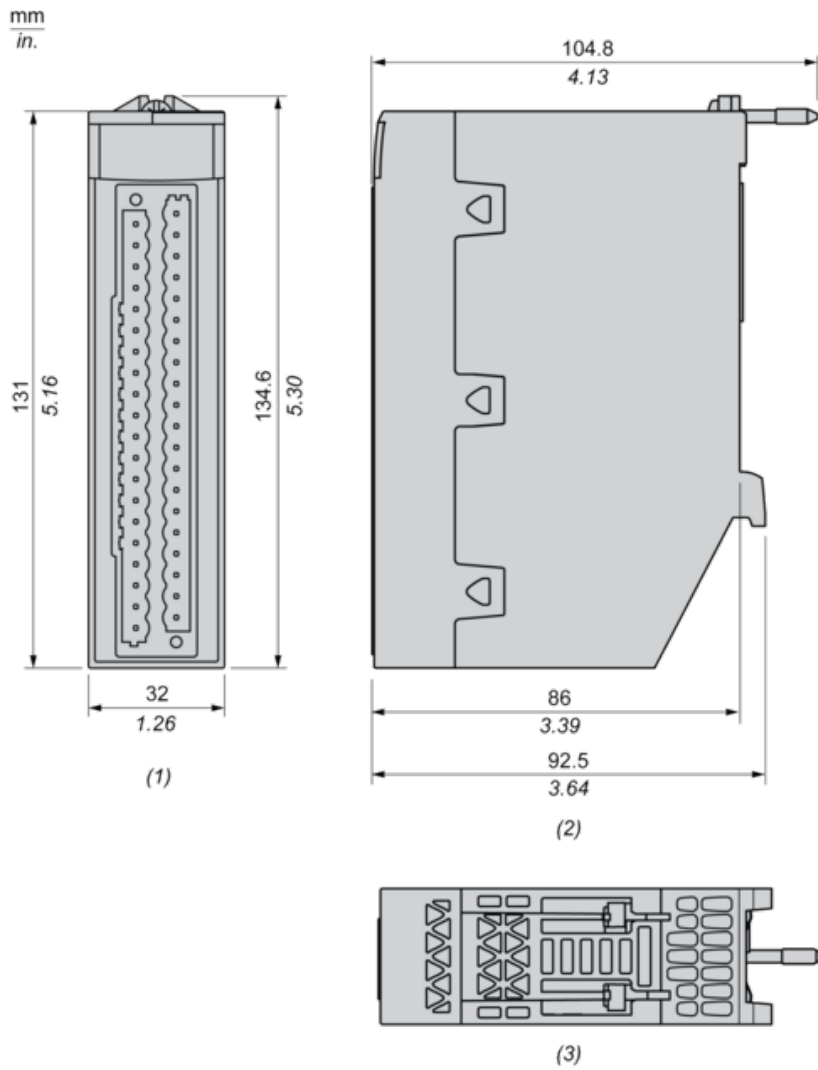

- (1) Front view
- (2) Right view
- (3) Top view

---

Connecting the Module

---

Output Circuit Diagram

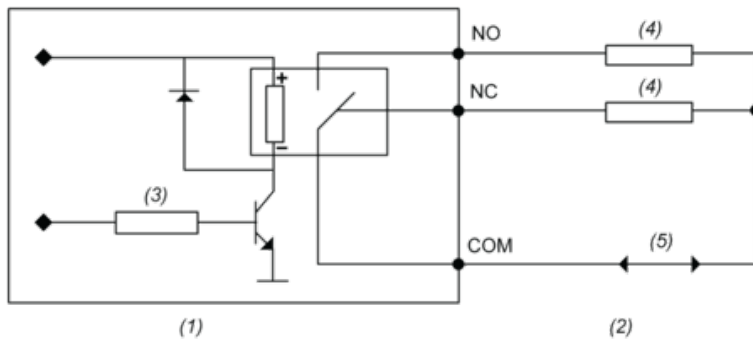

- (1) Module
  - (2) Output
  - (3) Command
  - (4) Pre-actuator
  - (5) Power supply
- NO : Normally open output  
NC : Normally closed output

## Module Connection

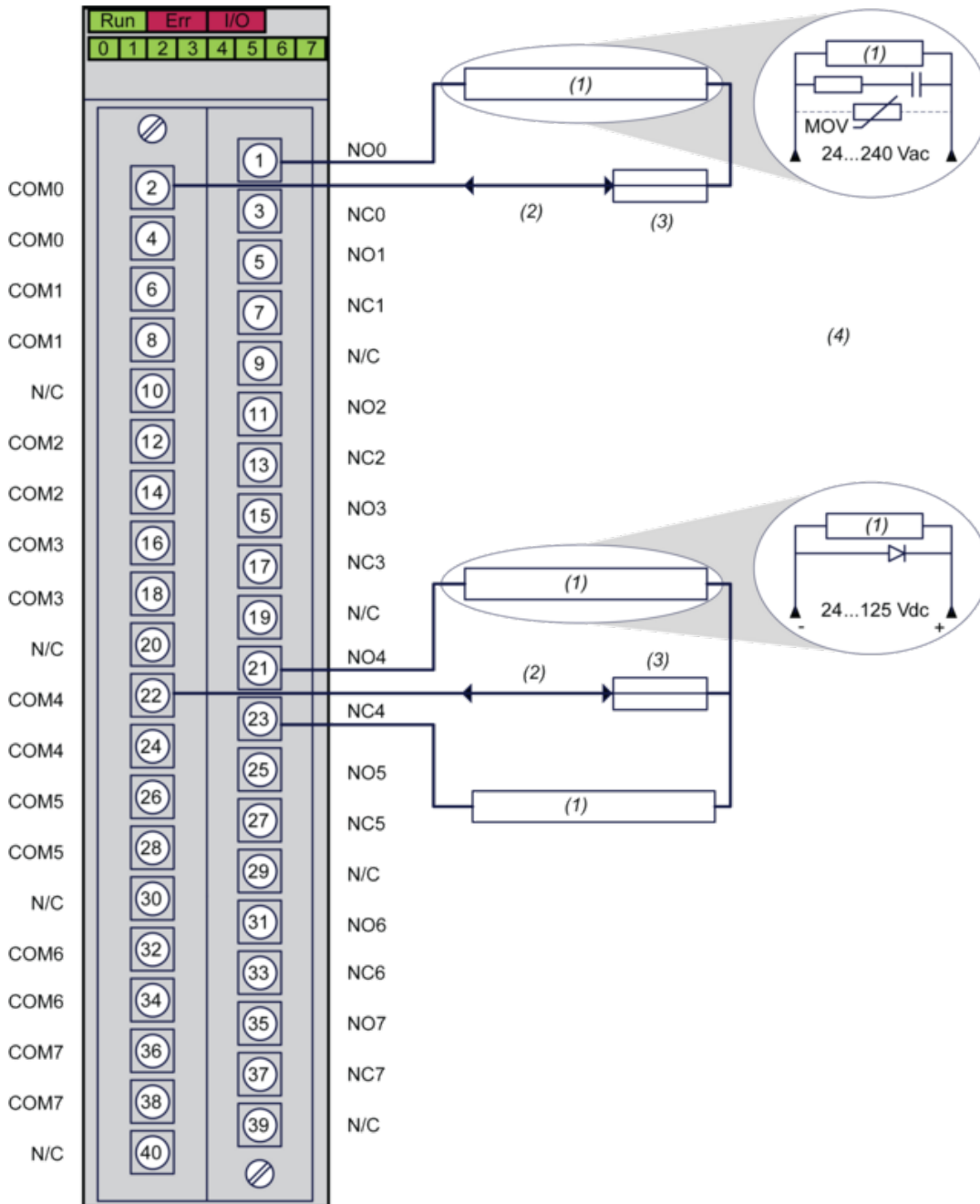

(1) Pre-actuator

(2) Power supply : 24...125 Vdc or 24...240 Vac

(3) Fuse : Use appropriate fast-blow fuse for each relay

(4) We recommend installing this type of protection on the terminals of each pre-actuator

N/C : Not connected