

# Product data sheet

## Characteristics

# XMLK150P2D73

pressure sensor XMLK - 0..150psi - 1/4NPT -  
0..10V - M12 - set of 1



### Main

Range of product	OsiSense XM
Product or component type	Electronic pressure sensors
Pressure sensor type	Pressure transmitter
Pressure sensor name	XMLK
Electrical circuit type	Control circuit
Pressure sensor size	150 psi (1034.21 kPa)
Local display	Without
Controlled fluid	Air 32...176 °F (0...80 °C)) Fresh water 32...176 °F (0...80 °C))
Fluid connection type	1/4" - 18 NPT (male)
Electrical connection	1 male connector M12 4 pins
[Us] rated supply voltage	24 V DC SELV 16.2...33 V)
Current consumption	< 6 mA
Type of output signal	Analogue
Analogue output function	0...10 V, 3-wire
Quantity per set	Set of 1
Type of packing	Individual

### Complementary

Pressure setting range	0...150 psi (0.00...1034.21 kPa)
Maximum permissible accidental pressure	300 psi (2068.43 kPa)
Destruction pressure	450 psi (3102.64 kPa)
Materials in contact with fluid	Ceramic Nitrile (NBR) Stainless steel type AISI 303
Operating position	Any position
Protection type	Reverse polarity Load short-circuit
Electromagnetic compatibility	Electrostatic discharge immunity test EN/IEC 61000-4-2 8 kV air, 6 kV contact Susceptibility to electromagnetic fields EN/IEC 61000-4-3 10 V/m 80...1000 MHz Electrical fast transient/burst immunity test EN/IEC 61000-4-4 2 kV 1.2/50 µs shock waves immunity test EN/IEC 61000-4-5 500 V 12 Ohm, 1 kV 42 Ohm

Disclaimer: This documentation is not intended as a substitute for and is not to be used for determining suitability or reliability of these products for specific user applications

Radiated RF fields EN/IEC 61000-4-6 10 V 0.15...80 MHz  
Immunity to magnetic fields EN/IEC 61000-4-8 30 A/m 50 Hz

[Uimp] rated impulse withstand voltage	0.5 kV
Response time on output	< 5 ms
Measurement accuracy	+/- 1 % of the measuring range
Resolution	0.1 % of the measuring range
Drift of the sensitivity	+/- 0.04 % of measuring range/°K
Drift of the zero point	+/- 0.03 % of measuring range/°K
Long term stability	+/- 1 % of the measuring range
Mechanical durability	10000000 cycles
Net weight	0.24 lb(US) (0.11 kg)
Diameter	1.42 in (36 mm)
Length	2.58 in (65.5 mm)
Scale type	Fixed differential

## Environment

Standards	EN/IEC 61326-2-3 CE
Product certifications	CSA C22.2 No 14 EAC UL 508 RCM
Protective treatment	TC
Ambient air temperature for operation	32...176 °F (0...80 °C)
Ambient air temperature for storage	-13...176 °F (-25...80 °C)
Vibration resistance	20 gn 9...2000 Hz) EN/IEC 60068-2-6
Shock resistance	25 gn 11 ms EN/IEC 60068-2-27
IP degree of protection	IP65 conforming to EN/IEC 60529
NEMA degree of protection	NEMA 4

## Packing Units

Unit Type of Package 1	PCE
Number of Units in Package 1	1
Package 1 Weight	4.41 oz (125 g)
Package 1 Height	1.65 in (4.2 cm)
Package 1 width	2.64 in (6.7 cm)
Package 1 Length	3.78 in (9.6 cm)
Unit Type of Package 2	S01
Number of Units in Package 2	24
Package 2 Weight	7.07 lb(US) (3.208 kg)
Package 2 Height	5.91 in (15 cm)
Package 2 width	5.91 in (15 cm)
Package 2 Length	15.75 in (40 cm)

## Offer Sustainability

REACH Regulation	<a href="#">REACH Declaration</a>
EU RoHS Directive	Pro-active compliance (Product out of EU RoHS legal scope) <a href="#">EU RoHS Declaration</a>
Mercury free	Yes
RoHS exemption information	<a href="#">Yes</a>

## Contractual warranty

Warranty	18 months
----------	-----------

Dimensions

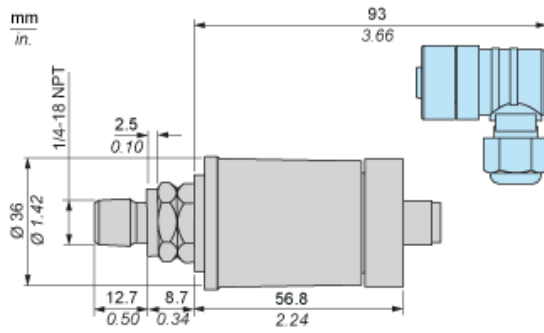

---

Wiring Diagram

---

3-Wire Technique (0-10 V)

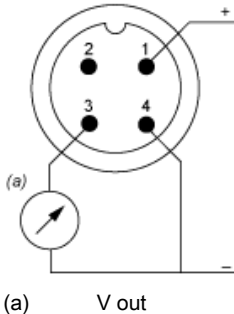

---

Output Curves

---

