



Main

| | |
|-----------------------------|--|
| Range of Product | Modicon Power Supply |
| Product or Component Type | Power supply |
| Power supply type | Regulated switch mode |
| Variant option | Optimized |
| Enclosure Material | Aluminum |
| Nominal input voltage | 100...240 V AC single phase 100...240 V AC phase to phase 140...340 V DC |
| Kw Rating | 480 W |
| Output voltage | 24 V DC |
| Power supply output current | 20 A |

Complementary

| | |
|---------------------------------|--|
| Efficiency at full load | 85...264 V AC without temperature derating 120...375 V DC without temperature derating |
| Nominal network frequency | 50...60 Hz |
| Network system compatibility | TN TT IT |
| Maximum leakage current | 1 mA 240 V AC |
| Input protection type | Integrated fuse (not interchangeable) 10 A External protection (recommended) 20 A Curve C External protection (recommended) 16 A Curve B External protection (recommended) 13 A Curve C |
| Inrush current | 45.0 A 115 V 90.0 A 230 V |
| Power factor | 0.95 at 115 V AC 0.95 at 230 V AC |
| Efficiency | 85 % 115 V AC 88 % 230 V AC |
| Output voltage adjustment | 22...28 V |
| Power dissipation in W | 60 W |
| Current consumption | < 5.4 A 115 V AC < 2.7 A 230 V AC < 5 A 140 V DC |
| Turn-on time | < 1.5 s |
| Holding time | > 20 ms 115 V AC > 20 ms 230 V AC |
| Startup with capacitive loads | 8000 µF |
| Residual ripple | < 120 mV |
| Meantime between failure [MTBF] | 700000 h at 77 °F (25 °C), full load conforming to SR 332 |
| Output protection type | Against overload and short-circuits automatic reset Against over temperature manual reset Against overvoltage manual reset |
| Connections - terminals | Screw connection 0.75...4 mm², AWG 20...AWG 12) without wire end ferrule output Screw connection 0.75...4 mm², AWG 20...AWG 14) with wire end ferrule output Screw connection 0.75...4 mm², AWG 18...AWG 12) without wire end ferrule input Screw connection 0.75...4 mm², AWG 18...AWG 12) with wire end ferrule input |

The information provided in this documentation contains general descriptions and/or technical characteristics of the performance of the products contained herein. This documentation is not intended as a substitute for and is not to be used for determining suitability or reliability of these products for specific user applications. It is the duty of any such user or integrator to perform the appropriate and complete risk analysis, evaluation and testing of the products with respect to the relevant specific application or use thereof. Neither Schneider Electric Industries SAS nor any of its affiliates or subsidiaries shall be responsible or liable for misuse of the information contained herein.

| | |
|--------------------------|---|
| Line and load regulation | < 0.5 % network 0 to 100 % load at 77 °F (25 °C) < 1 % network full voltage range in line at 77 °F (25 °C) |
| Status LED | 1 LED (Green) output voltage |
| Depth | 5.06 in (128.5 mm) |
| Height | 4.87 in (123.6 mm) |
| Width | 3.37 in (85.5 mm) |
| Net Weight | 2.76 lb(US) (1.25 kg) |
| Output coupling | Parallel Serial |
| Mounting support | Top hat type TH35-15 rail IEC 60715 Top hat type TH35-7.5 rail IEC 60715 Double-profile DIN rail |
| Supply | SELV IEC 60950-1 SELV IEC 60204-1 SELV IEC 60364-4-41 |
| Dielectric strength | 3000 V AC with input to output |
| Service life | 10 year(s) |
| Overvoltage category | II |

Environment

| | |
|---------------------------------------|---|
| Standards | IEC 62368-1 EN/IEC 61010-1 EN 61010-2-201 EN/IEC 61204-3 IEC 61000-6-1 IEC 61000-6-2 IEC 61000-6-3 IEC 61000-6-4 IEC 61000-3-2 EN 61000-3-3 UL 62368-1 UL 61010-1 UL 61010-2-201 CSA C22.2 No 62368-1 CSA C22.2 No 61010-1 CSA C22.2 No 61010-2-201 EN/IEC 62368-1 |
| Product certifications | CE[RETURN]CUL Listed[RETURN]CUL Recognized[RETURN]RCM[RETURN]CB Scheme[RETURN]EAC[RETURN]KC |
| Operating altitude | < 5000 m |
| Shock resistance | 150 m/s ² 11 ms |
| IP degree of protection | IP20 |
| Ambient air temperature for operation | -4...104 °F (-20...40 °C) without derating mounting position A 115 V AC < 6561.68 ft (2000 m) -4...122 °F (-20...50 °C) without derating mounting position A 230 V AC < 6561.68 ft (2000 m) 104...158 °F (40...70 °C) with current derating of 1.67 % per °C mounting position A 115 V AC < 6561.68 ft (2000 m) 122...158 °F (50...70 °C) with current derating of 2.5 % per °C mounting position A 230 V AC < 6561.68 ft (2000 m) |
| Electrical shock protection class | Class I |
| Pollution degree | 2 |
| Vibration resistance | 3 mm 2...9 Hz)IEC 60068-2-6 10 m/s ² 9...200 Hz)IEC 60068-2-6 |

| | |
|--------------------------|--|
| Electromagnetic immunity | <p>Immunity to electrostatic discharge - test level: 8 kV (contact discharge) conforming to IEC 61000-4-2</p> <p>Immunity to electrostatic discharge - test level: 15 kV (air discharge) conforming to IEC 61000-4-2</p> <p>Immunity to conducted RF disturbances - test level: 15 V/m (80 MHz...2 GHz) conforming to IEC 61000-4-3</p> <p>Immunity to conducted RF disturbances - test level: 5 V/m (2...2.7 GHz) conforming to IEC 61000-4-3</p> <p>Immunity to conducted RF disturbances - test level: 5 V/m (2.7...6 GHz) conforming to IEC 61000-4-3</p> <p>Immunity to fast transients - test level: 4 kV (on input-output) conforming to IEC 61000-4-4</p> <p>Surge immunity test - test level: 4 kV (between power supply and earth) conforming to IEC 61000-4-5</p> <p>Surge immunity test - test level: 3 kV (between phases) conforming to IEC 61000-4-5</p> <p>Immunity to conducted RF disturbances - test level: 15 V (0.15...80 MHz) conforming to IEC 61000-4-6</p> <p>Immunity to magnetic fields - test level: 30 A/m (50...60 Hz) conforming to IEC 61000-4-8</p> <p>Immunity to voltage dips conforming to IEC 61000-4-11</p> <p>Disturbing field emission conforming to EN 55016-2-3</p> <p>Limits for harmonic current emissions conforming to IEC 61000-3-2</p> <p>Conforming to EN 55016-1-2</p> <p>Conforming to EN 55016-2-1</p> |
| Electromagnetic emission | <p>Conducted emissions IEC 61000-6-3</p> <p>Radiated emissions IEC 61000-6-4</p> |

Ordering and shipping details

| | |
|-------------------|-----------------------------------|
| Category | 22525-ABL8 AND ABL7 POWER SUPPLIE |
| Discount Schedule | CP12 |
| GTIN | 3606481500267 |
| Returnability | Yes |
| Country of origin | TH |

Packing Units

| | |
|------------------------------|--------------------------|
| Unit Type of Package 1 | PCE |
| Number of Units in Package 1 | 1 |
| Package 1 Height | 3.74 in (9.5 cm) |
| Package 1 Width | 6.89 in (17.5 cm) |
| Package 1 Length | 7.09 in (18.0 cm) |
| Package 1 Weight | 3.13 lb(US) (1.419 kg) |
| Unit Type of Package 2 | S03 |
| Number of Units in Package 2 | 7 |
| Package 2 Height | 11.81 in (30 cm) |
| Package 2 Width | 11.81 in (30 cm) |
| Package 2 Length | 15.75 in (40 cm) |
| Package 2 Weight | 23.19 lb(US) (10.517 kg) |

Offer Sustainability

| | |
|----------------------------|---|
| Sustainable offer status | Green Premium product |
| California proposition 65 | WARNING: This product can expose you to chemicals including: Lead and lead compounds, which is known to the State of California to cause cancer and birth defects or other reproductive harm. For more information go to www.P65Warnings.ca.gov |
| REACH Regulation | REACH Declaration |
| EU RoHS Directive | Pro-active compliance (Product out of EU RoHS legal scope) |
| Mercury free | Yes |
| China RoHS Regulation | China RoHS Declaration |
| RoHS exemption information | Yes |
| Environmental Disclosure | Product Environmental Profile |

The product must be disposed on European Union markets following specific waste collection and never end up in rubbish bins.

Electrical Safety

- If the unit is use in a manner not specified by the manufacturer, the protection provided by the equipment may be impaired.
- For means of disconnection a switch or circuit breaker, located near the product, must be included in the installation. A marking as disconnecting device for the product is required.
- The device has an internal fuse. The unit is tested and approved with branch circuit protective device up to 20A. This circuit breaker can be used as disconnecting device.
- The power supply is only suitable for audio, video, information, communication, industrial and control equipment.

Dimensions

Front and Side Views

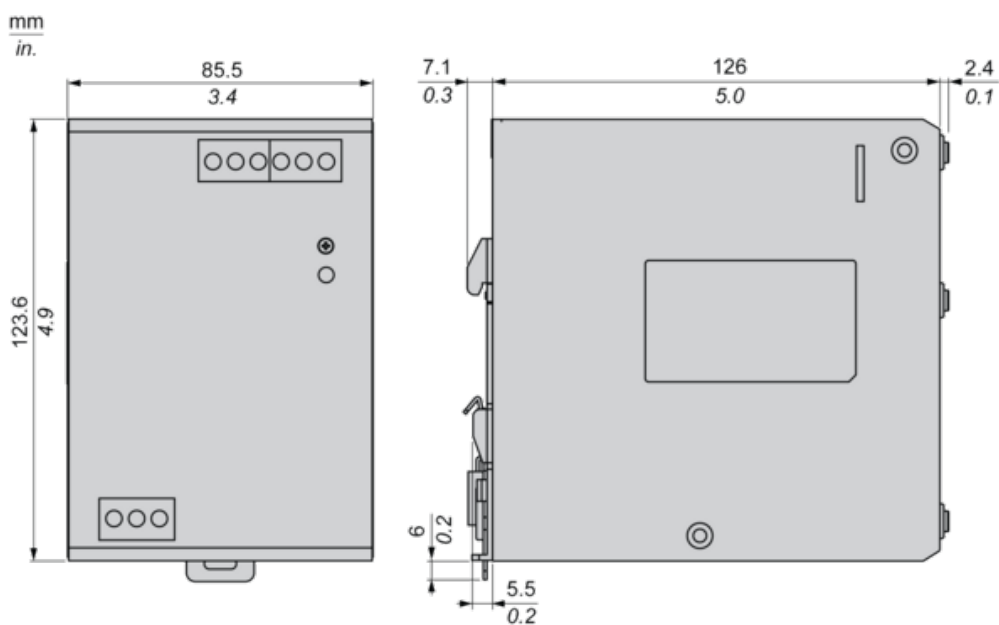

Connections and Schema

Wiring

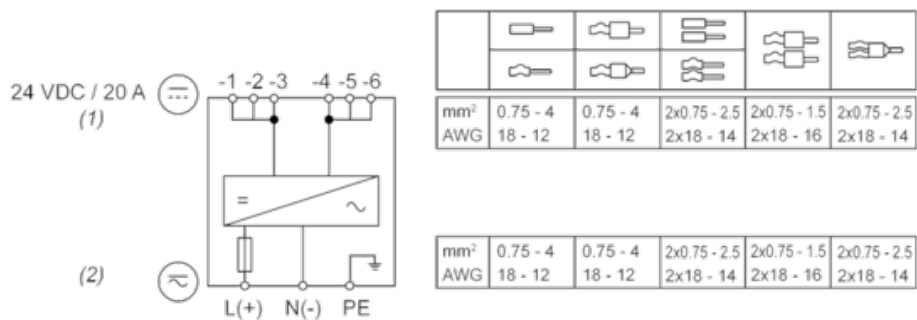

(1) : Output wiring

(2) : Input wiring

This is only the terminal wire rating. The wire size to be used in the application must be selected by the machine builder according to the ambient temperature, the wiring method and the end-use product standard. The unit has been tested and approved with input wire (80°C) and output wire 1 x 12AWG (95°C) or 3 x 18 AWG copper wire.

Correct Parallel Connection

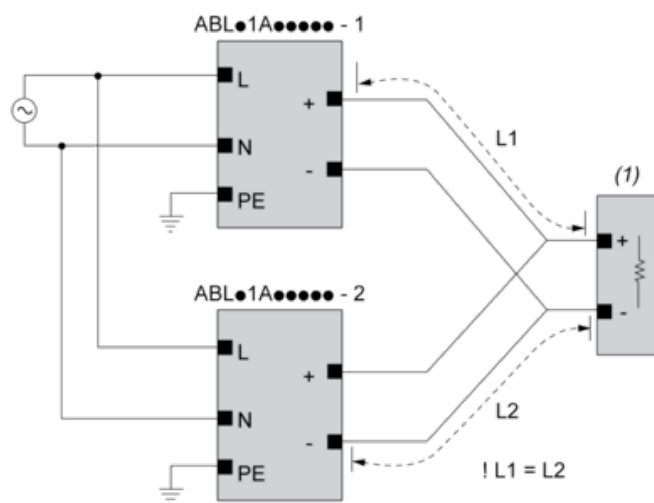

(1) : Load

Incorrect Parallel Connection

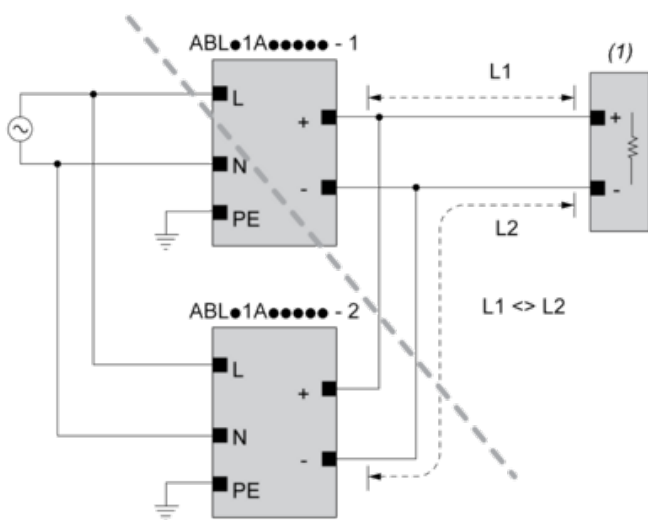

- (1) : Load
- ABLx1Axxxxx-1 = ABLx1Axxxxx-2
- max 2 x ABLx1Axxxxx
- L1 = L2
- ΔV max 25 mV
- $I_{Load} < 90\% \times 2 \times I_{nom}$

Output Voltage Balancing

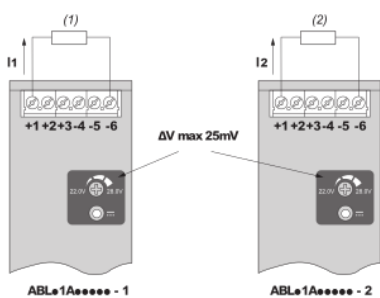

- (1) : R_{Load1}
- (2) : R_{Load2}
- $R_{Load1} = R_{Load2}$
- $I_1 = I_2 = \sim I_{nom}$

Series Connection

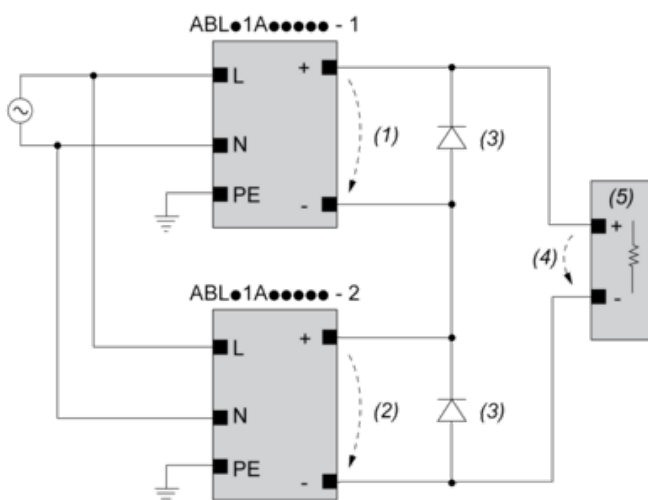

- (1) : V_{out1}
- (2) : V_{out2}
- (3) : 2 x Diode, $V_{RRM} > 2 \times V_{out1/2}$, $I_F > 2 \times I_{nom1/2}$
- (4) : $V_{Load} = 2 \times V_{out}$

(5) : Load

Mounting

Mounting Position A

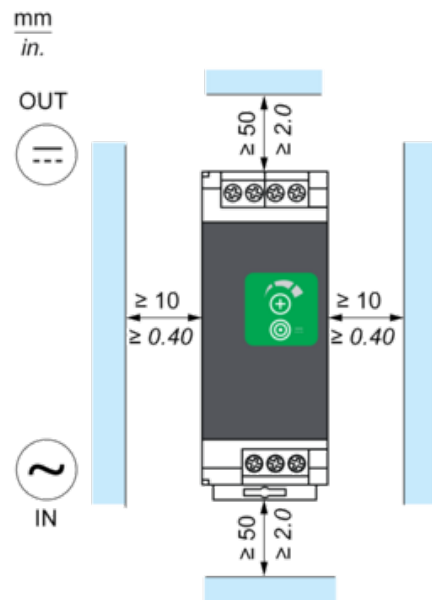

Mounting Position B

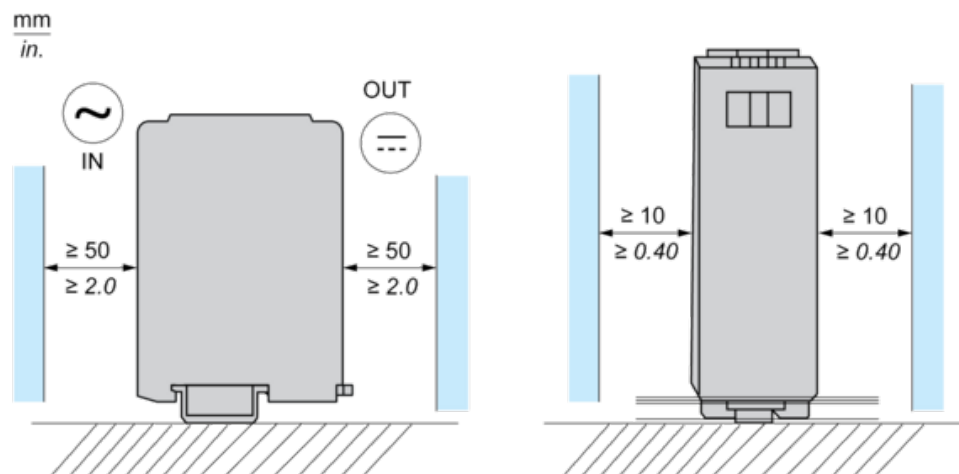

Incorrect Mounting

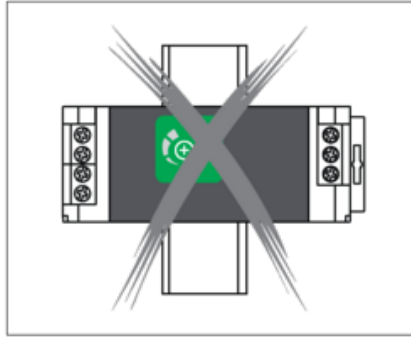
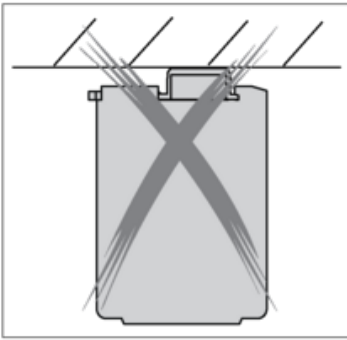
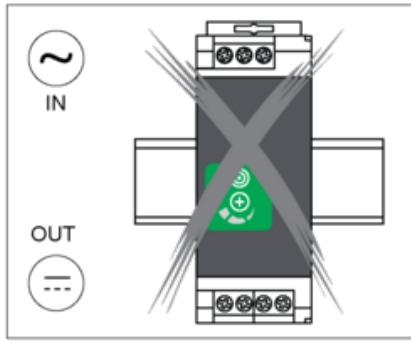
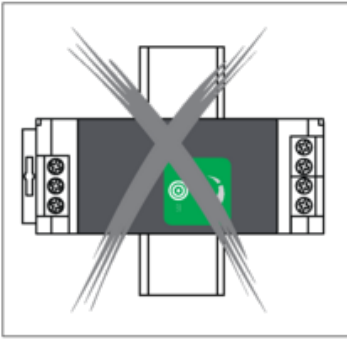

Performance Curve

Mounting Position A

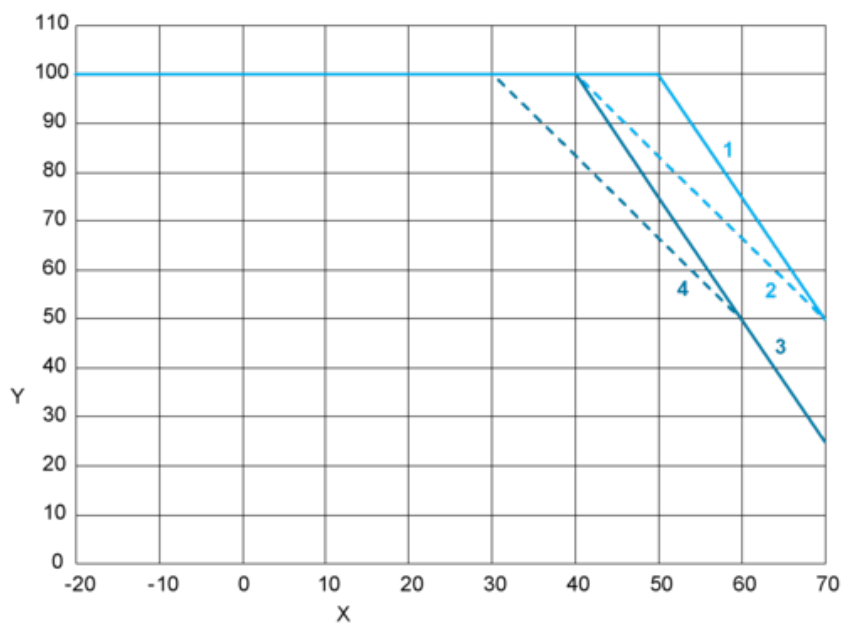

Mounting Position B

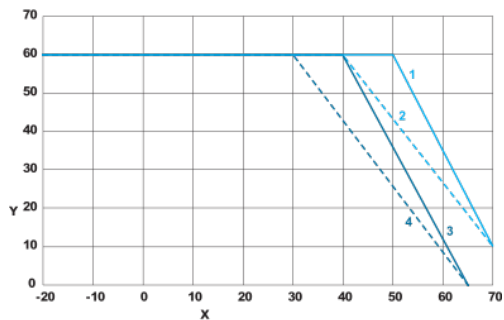

X : Surrounding Air Temperature (°C)

Y : Percentage of Maximum Load (%)

1 : Altitude ≤ 2000 m (6561 ft), Input voltage = 230 VAC / 325 VDC

2 : Altitude ≤ 2000 m (6561 ft), 115 VAC / 162 VDC

3 : Altitude ≤ 5000 m (16404 ft), Input voltage = 230 VAC / 325 VDC

4 : Altitude ≤ 5000 m (16404 ft), 115 VAC / 162 VDC

DC input voltage

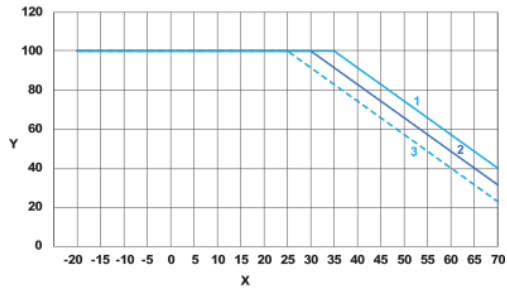

X : Surrounding Air Temperature (°C)

Y : Percentage of Maximum Load (%)

1 : 110 VDC

2 : 90 VDC

3 : 85 VDC