



## Main

Range of Product	Modicon X80
Product or Component Type	Discrete output module
Discrete output number	16 EN/IEC 61131-2
Discrete output type	Triac
Discrete output voltage	24...240 V 20...264 V AC
Discrete output current	3 A

## Complementary

Network Frequency	50/60 Hz
Network frequency limits	47...63 Hz
Sensor power supply	20...264 V
Current per channel	3 A 104 °F (40 °C) 1.2 A 140 °F (60 °C)
Maximum current per module	10 A 104 °F (40 °C) 4 A 140 °F (60 °C)
Maximum leakage current	1 MA at state 0 24 V 1 MA at state 0 48 V 2 MA at state 0 115 V 2.5 mA at state 0 240 V
Maximum voltage drop	<1.55 V at state 1
Insulation resistance	> 10 MOhm 500 V DC
Power dissipation in W	1.45 W
Response time on output	<= 10 ms resistive activation <= 10 ms resistive deactivation
Typical current consumption	61 MA 3.3 V DC 50 mA 24 V DC
MTBF reliability	500000 H
Protection type	1 external fuse 4 A fast blow
Output overload protection	With varistor
Inrush current	30 A
Maximum current per output common	4 A
Output current limits	0.005...10 A
Status LED	1 LED (Green) module operating (RUN) 1 LED per channel (Green) channel diagnostic 1 LED (Red) module error (ERR) 1 LED (Red) module I/O
Net Weight	0.58 lb(US) (0.264 kg)

## Environment

IP Degree of Protection	IP20
Dielectric strength	3000 V AC 50/60 Hz 1 min
Vibration resistance	3 gn
Shock resistance	30 gn
Ambient Air Temperature for Storage	-40...185 °F (-40...85 °C)
Ambient Air Temperature for Operation	32...140 °F (0...60 °C)

Relative humidity	0...95 % 32...140 °F (0...60 °C) without condensation
Operating altitude	0...6561.68 ft (0...2000 m) 2000...5000 m with derating factor

## Ordering and shipping details

Category	18160-MODICON M340
Discount Schedule	PC34
GTIN	3606489485047
Returnability	Yes
Country of origin	FR

## Packing Units

Unit Type of Package 1	PCE
Number of Units in Package 1	1
Package 1 Height	2.17 in (5.500 cm)
Package 1 Width	7.09 in (18.000 cm)
Package 1 Length	10.24 in (26.000 cm)
Package 1 Weight	14.29 oz (405.000 g)
Unit Type of Package 2	S03
Number of Units in Package 2	8
Package 2 Height	11.81 in (30.000 cm)
Package 2 Width	11.81 in (30.000 cm)
Package 2 Length	15.75 in (40.000 cm)
Package 2 Weight	8.16 lb(US) (3.700 kg)

## Offer Sustainability

California proposition 65	WARNING: This product can expose you to chemicals including: Lead and lead compounds, which is known to the State of California to cause cancer and birth defects or other reproductive harm. For more information go to <a href="http://www.P65Warnings.ca.gov">www.P65Warnings.ca.gov</a>
REACH Regulation	 <a href="#">REACH Declaration</a>
EU RoHS Directive	Pro-active compliance (Product out of EU RoHS legal scope)
Mercury free	Yes
China RoHS Regulation	 <a href="#">China RoHS Declaration</a>
RoHS exemption information	 <a href="#">Yes</a>
WEEE	The product must be disposed on European Union markets following specific waste collection and never end up in rubbish bins.

Dimensions

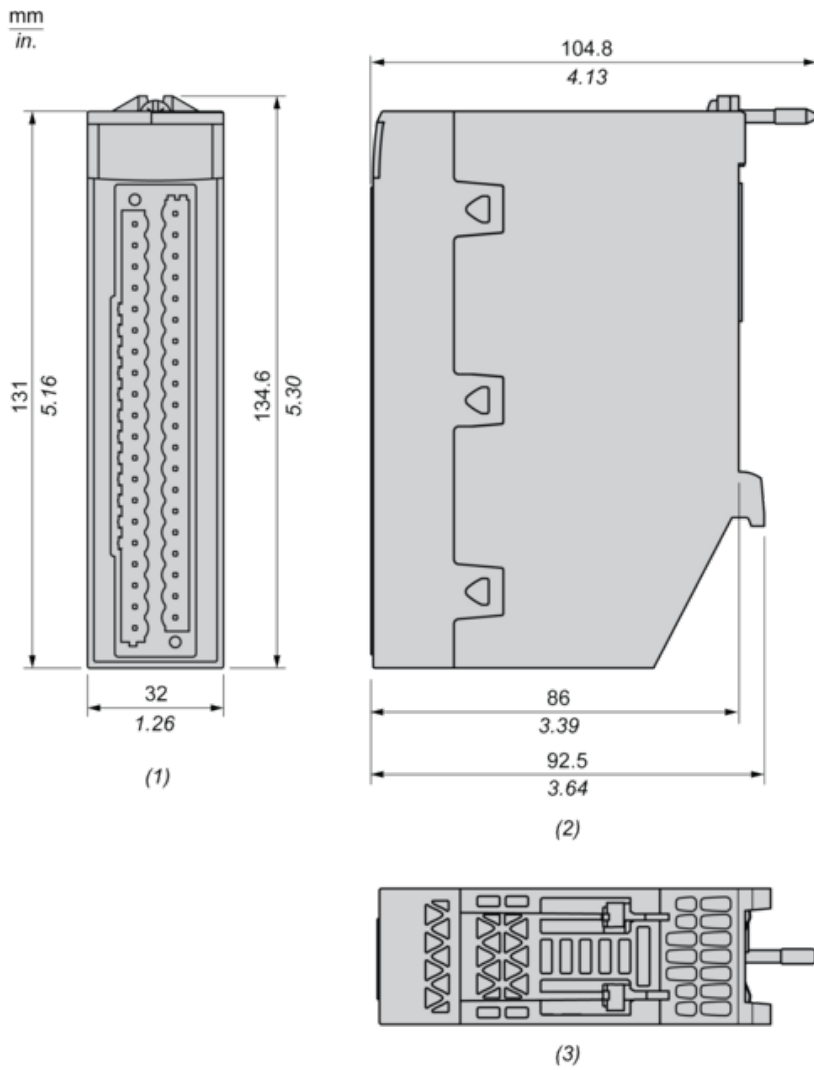

- (1) Front view
- (2) Right view
- (3) Top view

## Connecting the Module

### Output Circuit Diagram

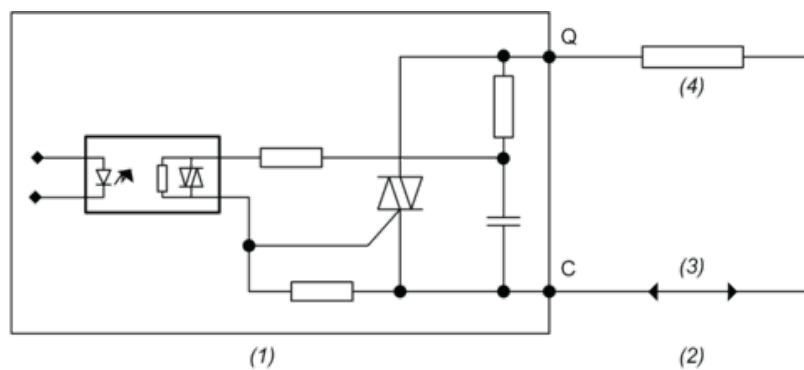

- (1) Module
- (2) Output
- (3) Power supply
- (4) Pre-actuator

## Module Connection

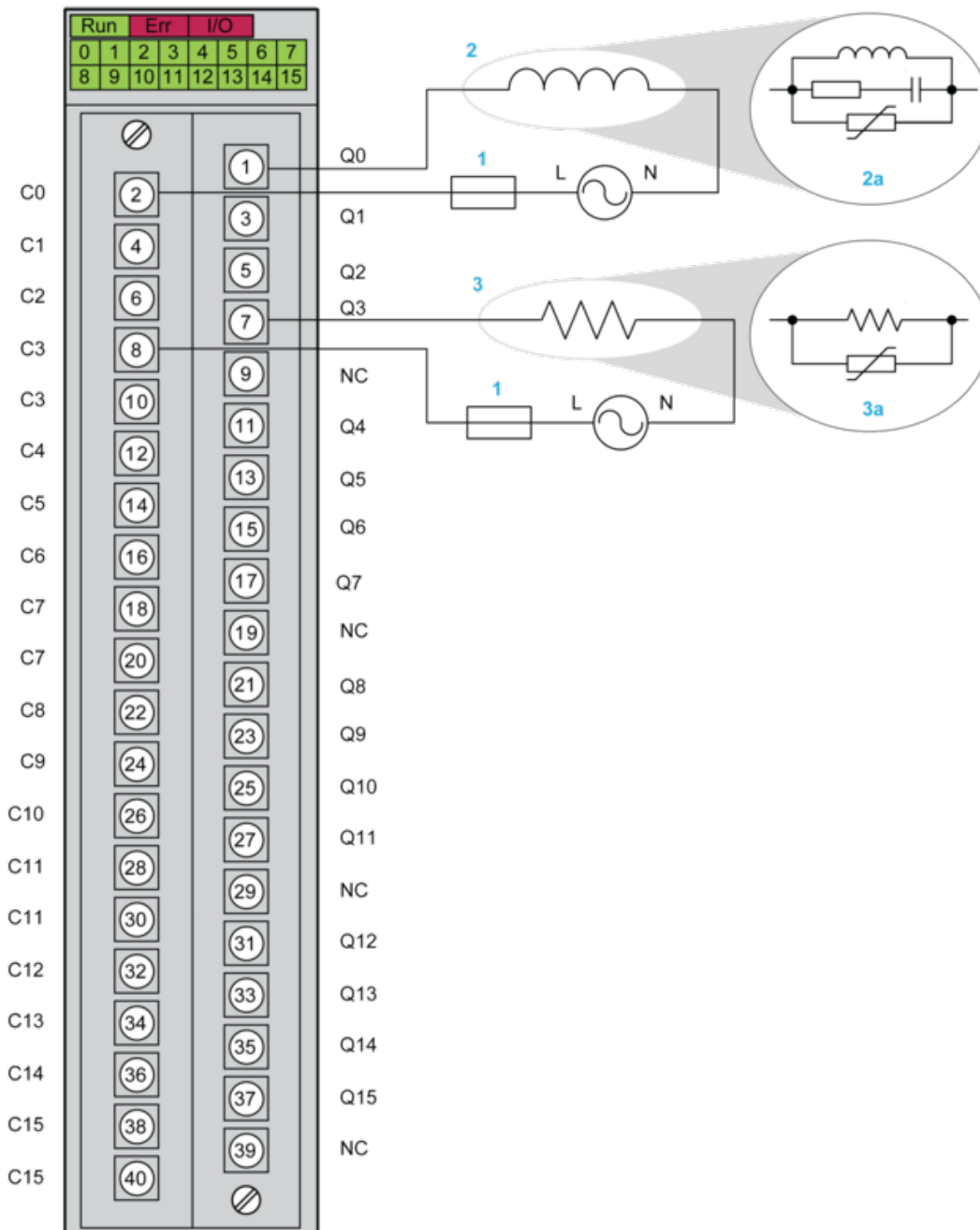

NC: Not connected

1 : 4 A fast blow fuse

2 : Inductive load

3 : Resistive load

2a and 3a : Recommended output protection