

## Main

Range of Product	Lexium integrated drive
Product or Component Type	Motion integrated drive
Device short name	ILA
Motor Type	AC Synchronous Servo Motor
Number of motor poles	6
Phase	Single phase
[Us] rated supply voltage	24 V 36 V
Network type	DC
Communication interface	CANopen DS301, Integrated
Length	8.24 in (209.3 mm)
Winding type	High speed of rotation and medium torque
Electrical Connection	Industrial connector
Holding brake	With
Gear box type	Without
Nominal speed	3100 rpm 24 V 5000 rpm 36 V
Nominal torque	3.63 lbf.in (0.41 N.m)
Holding torque	10.62 lbf.in (1.2 N.m) holding brake

## Complementary

Transmission Rate	50, 100, 125, 250, 500, 800 and 1000 kbauds
Mounting Support	Flange
Motor flange size	2.24 in (57 mm)
Number of motor stacks	2
Centring collar diameter	1.97 in (50 mm)
Centring collar depth	0.06 in (1.6 mm)
Number of mounting holes	4
Mounting holes diameter	0.20 in (5.2 mm)
Circle diameter of the mounting holes	2.62 in (66.6 mm)
Feedback type	Single turn encoder
Shaft end	Untapped
Second shaft	Without second shaft end
Shaft diameter	0.35 in (9 mm)
Shaft length	0.79 in (20 mm)
Supply voltage limits	18...40 V
Current consumption	7500 mA maximum continuous 9000 mA peak
Associated fuse rating	10 A
Input/output type	4 signals (each be used as input or output)
Voltage state 0 guaranteed	-3...4.5 V
Voltage state 1 guaranteed	15...30 V
Discrete input current	10 MA at 24 V on/STO_A safety input 3 MA at 24 V on/STO_B safety input 2 mA at 24 V 24 V signal interface
Discrete output voltage	23...25 V

The information provided in this documentation contains general descriptions and/or technical characteristics of the performance of the products contained herein. This documentation is not intended as a substitute for and is not to be used for determining suitability or reliability of these products for specific user applications. It is the duty of any such user or integrator to perform the appropriate and complete risk analysis, evaluation and testing of the products with respect to the relevant specific application or use thereof. Neither Schneider Electric Industries SAS nor any of its affiliates or subsidiaries shall be responsible or liable for misuse of the information contained herein.

Maximum switching current	100 MA per output 200 mA total
Protection Type	Overload of output voltage Short circuit of the output voltage Safe torque off
Peak stall torque	5.40 lbf.in (0.61 N.m)
Continuous stall torque	3.63 lbf.in (0.41 N.m)
Speed feedback resolution	16384 points/turn x 4096 turns
Accuracy error	+/- 0.05 °
Rotor inertia	0.25 kg.cm <sup>2</sup>
Maximum radial force Fr	107 N
Maximum axial force Fa	104 N force pressure) 104 N tensile force)
Service life in hours	20000 h bearing
Brake pull-in power	10 W
Brake release time	14 ms
Brake application time	13 ms
Marking	CE
Type of cooling	Natural convection
Net Weight	3.75 lb(US) (1.7 kg)

## Environment

Standards	IEC 60072-1 EN 50347 EN 61800-3:2001, second environment EN/IEC 50178 EN 61800-3 : 2001-02 IEC 61800-3, Ed 2 EN/IEC 61800-3
Product Certifications	TÜV[RETURN]cUL[RETURN]JUL
Ambient air temperature for operation	122...149 °F (50...65 °C) with power derating of 2 % per °C) 32...122 °F (0...50 °C) without derating)
Permissible ambient air temperature around the device	221 °F (105 °C) power amplifier 230 °F (110 °C) motor
Ambient Air Temperature for Storage	-13...158 °F (-25...70 °C)
Operating altitude	<= 3280.84 ft (1000 m) without derating
Relative humidity	15...85 % without condensation
Vibration resistance	20 m/s <sup>2</sup> 10...500 Hz) 10 cycles EN/IEC 60068-2-6
Shock resistance	150 m/s <sup>2</sup> 1000 shocks EN/IEC 60068-2-29
IP degree of protection	Shaft bushing IP41 EN/IEC 60034-5 Total except shaft bushing IP54 EN/IEC 60034-5

## Ordering and shipping details

Category	18288-LEXIUM INTEGRATED DRIVES II
Discount Schedule	PC56
GTIN	3389119225601
Returnability	No
Country of origin	DE

## Packing Units

Unit Type of Package 1	PCE
Number of Units in Package 1	1
Package 1 Height	3.15 in (8.0 cm)
Package 1 Width	7.48 in (19.0 cm)
Package 1 Length	15.35 in (39.0 cm)
Package 1 Weight	5.51 lb(US) (2.5 kg)

## Offer Sustainability

Sustainable offer status	Green Premium product
California proposition 65	WARNING: This product can expose you to chemicals including: Lead and lead compounds, which is known to the State of California to cause cancer and birth defects or other reproductive harm. For more information go to <a href="http://www.P65Warnings.ca.gov">www.P65Warnings.ca.gov</a>
REACH Regulation	<a href="#">REACH Declaration</a>
EU RoHS Directive	Pro-active compliance (Product out of EU RoHS legal scope)
Mercury free	Yes
China RoHS Regulation	<a href="#">China RoHS Declaration</a>
RoHS exemption information	<a href="#">Yes</a>
Environmental Disclosure	<a href="#">Product Environmental Profile</a>
Circularity Profile	<a href="#">End Of Life Information</a>
WEEE	The product must be disposed on European Union markets following specific waste collection and never end up in rubbish bins.
PVC free	Yes

## Contractual warranty

Warranty	18 months
----------	-----------

Integrated Drive with Holding Brake

Dimensions

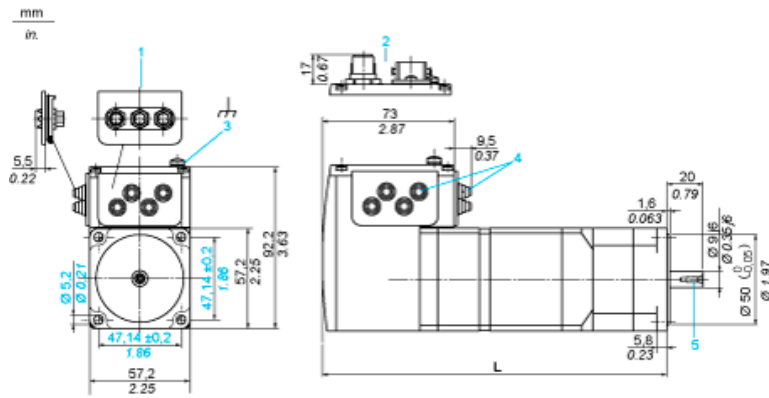

- 1 Accessories: I/O signal insert with industrial connectors
- 2 Option: industrial connectors
- 3 Earth (ground) terminal
- 4 Accessories: cable entries  $\varnothing = 3 \dots 9 \text{ mm} / 0.12 \dots 0.35 \text{ in.}$
- 5 Centring hole DIN 332 - DS M3
- L 209.3 mm/8.24 in.

Connection Example with 4 I/O Signals



Torque Characteristics

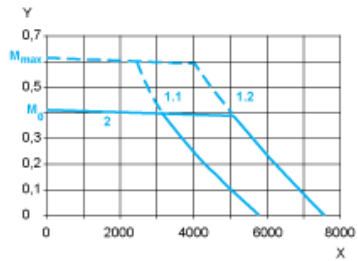

- X Speed of rotation in rpm  
Y Torque in Nm  
1.1 Max. torque at 24 V  
1.2 Max. torque at 36 V  
2 Continuous torque