

# BCH2MM2020CA6C

servo motor BCH, Lexium 28, 130mm, 2000W, 13.5kg.cm<sup>2</sup>, without oil seal, smooth, straight connection



## Main

Range Compatibility	Lexium 28
Product or Component Type	Servo motor
Device short name	BCH2

## Complementary

Maximum mechanical speed	3000 rpm
[Us] rated supply voltage	220 V
Phase	Three phase
Continuous stall current	9.95 A
Continuous stall torque	84.52 lbf.in (9.55 N.m) LXM28... 12 A, 220 V, three phase
Continuous power	2000 W
Peak stall torque	253.57 lbf.in (28.65 N.m) LXM28... 12 A, 220 V, three phase
Nominal output power	2000 W LXM28... 12 A, 220 V, three phase
Nominal torque	84.52 lbf.in (9.55 N.m) LXM28... 12 A, 220 V, three phase
Nominal speed	2000 rpm LXM28... 12 A, 220 V, three phase
Maximum current Irms	32.85 A LXM28... 2 kW, 220 V
Maximum permanent current	11.25 A
Product compatibility	LXM28... servo drive 2 kW, 220 V, three phase
Shaft end	Smooth shaft
Shaft diameter	0.87 in (22 mm)
Shaft length	2.17 in (55 mm)
Feedback type	20 bits single turn absolute encoder
Holding brake	Without
Mounting Support	Asian standard flange
Motor flange size	5.12 in (130 mm)
Electrical connection	Connector MIL
Torque constant	0.96 N.m/A 68 °F (20 °C)
Back emf constant	58 V/krpm 68 °F (20 °C)
Rotor inertia	13.5 kg.cm <sup>2</sup>
Stator resistance	0.34 Ohm 68 °F (20 °C)
Stator inductance	4.5 mH 68 °F (20 °C)
Stator electrical time constant	13.24 ms 68 °F (20 °C)
Maximum radial force Fr	670 N 2000 rpm
Maximum axial force Fa	200 N
Brake pull-in power	19.7 W
Type of cooling	Natural convection
Length	7.36 in (187 mm)
Number of motor stacks	4

Centring collar diameter	4.33 in (110 mm)
Centring collar depth	0.31 in (8 mm)
Number of mounting holes	4
Mounting holes diameter	0.36 in (9.2 mm)
Circle diameter of the mounting holes	5.71 in (145 mm)
Distance shaft shoulder-flange	0.31 in (8 mm)
Net Weight	21.38 lb(US) (9.7 kg)

## Environment

IP Degree of Protection	IP54 IM B5, IM V1 IP50 IM V3
Ambient Air Temperature for Operation	-4...104 °F (-20...40 °C)

## Ordering and shipping details

Category	18281-LEXIUM 23/28 MOTORS
Discount Schedule	PC53
GTIN	3606480734366
Returnability	No
Country of origin	CN

## Packing Units

Unit Type of Package 1	PCE
Number of Units in Package 1	1
Package 1 Height	7.13 in (18.1 cm)
Package 1 Width	9.06 in (23 cm)
Package 1 Length	14.17 in (36 cm)
Package 1 Weight	19.67 lb(US) (8.92 kg)

## Offer Sustainability

Sustainable offer status	Green Premium product
California proposition 65	WARNING: This product can expose you to chemicals including: Lead and lead compounds, which is known to the State of California to cause cancer and birth defects or other reproductive harm. For more information go to <a href="http://www.P65Warnings.ca.gov">www.P65Warnings.ca.gov</a>
REACH Regulation	<a href="#">REACH Declaration</a>
REACH free of SVHC	Yes
EU RoHS Directive	Pro-active compliance (Product out of EU RoHS legal scope)
Mercury free	Yes
China RoHS Regulation	<a href="#">China RoHS Declaration</a>
RoHS exemption information	<a href="#">Yes</a>
Environmental Disclosure	<a href="#">Product Environmental Profile</a>
Circularity Profile	<a href="#">End Of Life Information</a>
WEEE	The product must be disposed on European Union markets following specific waste collection and never end up in rubbish bins.
PVC free	Yes

Dimensions

Dimensions of Motor

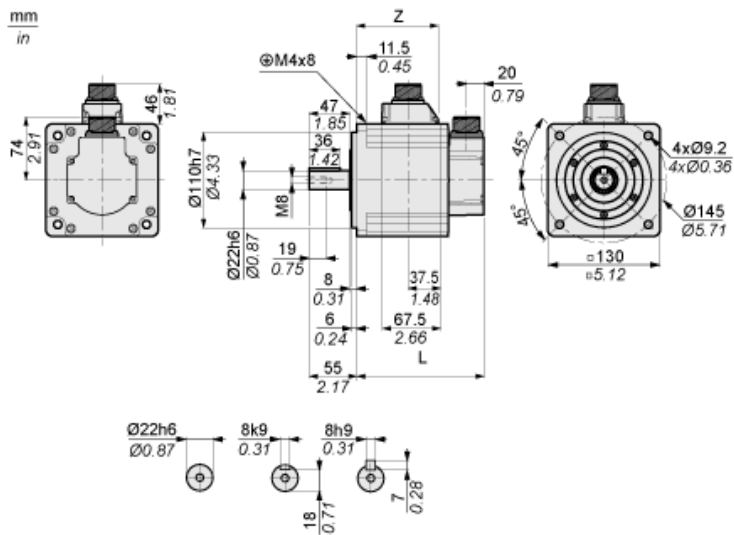

	mm	in.
L (without holding brake)	187	7.36
L (with holding brake)	216	8.5
Z	134.5	5.30

---

Torque/Speed Curves with 230 V Three Phase Supply Voltage

---

Servo Motor with LXM28AU20●●● Servo Drive

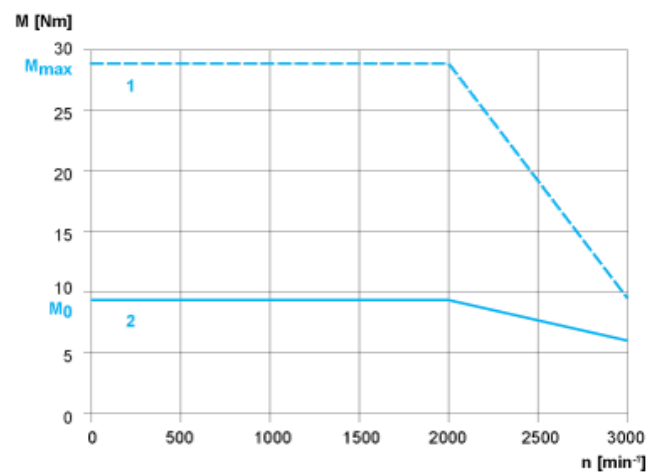

- 1 : Peak torque
- 2 : Continuous torque