

Product data sheet

Characteristics

VRKT5M1FNC00000

Delta 2 robot, T5 HD, 2-3 axis, 45 kg permissible load, 0-1500 mm working envelop

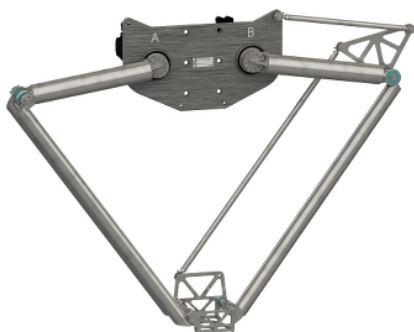

Main

Range of Product	Lexium P, T
Product or Component Type	Delta 2 robot
Device short name	T5 HD
Design	Compact

Complementary

Number of axis	2
Work envelope	76.57 In (1945 mm) diameter 0.00...59.06 In (0...1500 mm) horizontal 0.00...27.76 in (0...705 mm) vertical
Repeat accuracy	0.1 mm
Permanent permissible load	99.21 lb(US) (45 kg)
Maximum actuation speed	13.12 ft/s (4 m/s)
Maximum acceleration	131.23 ft/s ² (40 m/s ²)
Net Weight	143.30 lb(US) (65 kg)
Range Compatibility	Lexium MH3 motor

Environment

Environmental characteristic	Normal environment
------------------------------	--------------------

Ordering and shipping details

Category	18357-PACDRIVE ROBOTIC
Discount Schedule	PC52
GTIN	3606485459226
Returnability	No

Packing Units

Unit Type of Package 1	PCE
Number of Units in Package 1	1
Package 1 Height	36.22 in (92.0 cm)
Package 1 Width	47.44 in (120.5 cm)
Package 1 Length	47.44 in (120.5 cm)
Package 1 Weight	207.23 lb(US) (94.0 kg)