

BMP1402C3NA2A

synchronous motor - BMP - 480 VAC - 2.2 kW - IP65 - IEC



Main

Product or Component Type	Synchronous motor
Device short name	BMP
Maximum mechanical speed	3600 rpm
Nominal output power	2200 W ATV32 2.2 kW 400 V three phase 2200 W ATV320 2.2 kW 400 V three phase
Nominal torque	124.00 Lbf.in (14.01 N.m) ATV32 2.2 kW 400 V three phase 124.00 lbf.in (14.01 N.m) ATV320 2.2 kW 400 V three phase
Nominal speed	1500 rpm ATV32 2.2 kW 400 V three phase 1500 rpm ATV320 2.2 kW 400 V three phase
Product compatibility	Variable speed drive ATV32 2.2 kW 400 V three phase Variable speed drive ATV320 2.2 kW 380...500 V three phase
Shaft end	Keyed
IP Degree of Protection	IP65 standard IP67 with IP67 kit
Holding brake	Without
Mounting Support	International standard flange
Electrical Connection	Rotatable right-angled connector

Complementary

Range Compatibility	Altivar Machine ATV320 Altivar 32
[Us] rated supply voltage	480 V
Phase	Three phase
Maximum current Irms	8.3 A ATV32 2.2 kW 400 V three phase 8.3 A ATV320 2.2 kW 400 V three phase
Nominal operating frequency	125 Hz ATV32 2.2 kW 400 V three phase 125 Hz ATV320 2.2 kW 400 V three phase
Minimum operating frequency	13 Hz ATV32 2.2 kW 400 V three phase 13 Hz ATV320 2.2 kW 400 V three phase
Maximum operating frequency	300 Hz ATV32 2.2 kW 400 V three phase 300 Hz ATV320 2.2 kW 400 V three phase
Shaft diameter	0.94 in (24 mm)
Shaft length	1.97 in (50 mm)
Key width	0.31 in (8 mm)
Motor flange size	5.51 in (140 mm)
Torque constant	2.9 N.m/A 104 °F (40 °C)
Number of motor poles	5
Number of motor stacks	2
Rotor inertia	32 kg.cm ²
Stator resistance	1.24 Ohm 104 °F (40 °C)
Stator inductance	15.52 mH for q-axis winding 104 °F (40 °C) 13.86 mH for d-axis winding 104 °F (40 °C)
Maximum radial force Fr	2240 N 1000 rpm 1780 N 2000 rpm 1550 N 3000 rpm
Maximum axial force Fa	0.2 x Fr
Type of cooling	Natural convection

Length	7.56 in (192 mm)
Centring collar diameter	5.12 in (130 mm)
Centring collar depth	0.14 in (3.5 mm)
Number of mounting holes	4
Mounting holes diameter	0.43 in (11 mm)
Circle diameter of the mounting holes	6.50 in (165 mm)
Net Weight	26.46 lb(US) (12 kg)

Ordering and shipping details

Category	18282-LEXIUM 32 MOTORS
Discount Schedule	PC53
GTIN	3606480564499
Returnability	No
Country of origin	DE

Packing Units

Unit Type of Package 1	PCE
Number of Units in Package 1	1
Package 1 Height	10.24 in (26.0 cm)
Package 1 Width	7.87 in (20.0 cm)
Package 1 Length	23.23 in (59.0 cm)
Package 1 Weight	29.94 lb(US) (13.582 kg)
Unit Type of Package 2	P06
Number of Units in Package 2	4
Package 2 Height	30.31 in (77.0 cm)
Package 2 Width	31.50 in (80.0 cm)
Package 2 Length	23.62 in (60.0 cm)
Package 2 Weight	138.51 lb(US) (62.828 kg)

Offer Sustainability

California proposition 65	WARNING: This product can expose you to chemicals including: Lead and lead compounds, which is known to the State of California to cause cancer and birth defects or other reproductive harm. For more information go to www.P65Warnings.ca.gov
REACH Regulation	REACH Declaration
EU RoHS Directive	Pro-active compliance (Product out of EU RoHS legal scope)
Mercury free	Yes
China RoHS Regulation	China RoHS Declaration
RoHS exemption information	Yes
WEEE	The product must be disposed on European Union markets following specific waste collection and never end up in rubbish bins.
PVC free	Yes

Contractual warranty

Warranty	18 months
----------	-----------

Dimensions

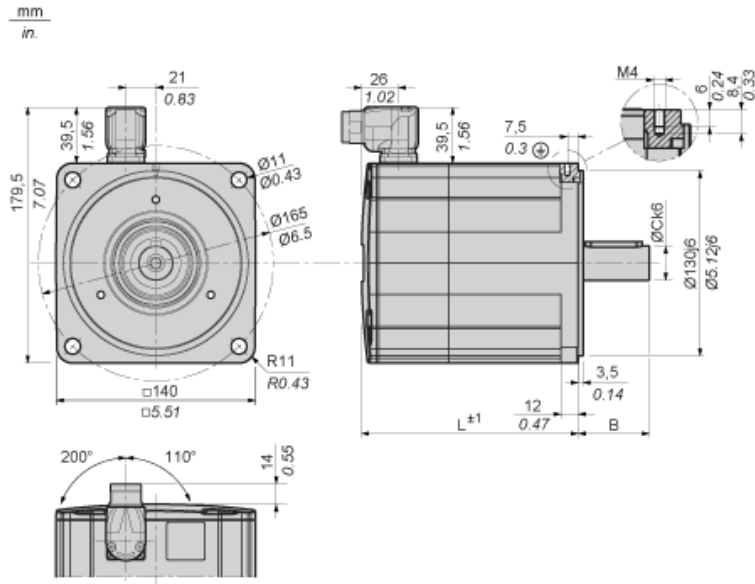

Parallel Key According to DIN 6885 A

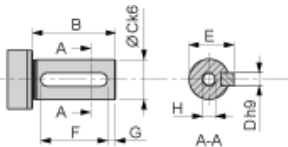

Female Thread of Shaft According to DIN 332-D

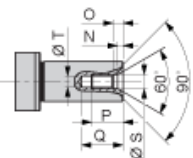

L	mm	192
in.	7.56	
B	mm	50
in.	1.97	
C	mm	24
in.	0.94	
D	mm	8
in.	0.31	
E	mm	27
in.	1.06	
F	mm	40
in.	1.57	
G	mm	5
in.	0.20	

H		M8
N	mm	3.3
in.	0.13	
O	mm	6
in.	0.24	
P	mm	19
in.	0.75	
Q	mm	25
in.	0.98	
S	mm	8.4
in.	0.33	
T	mm	6.8
in.	0.27	

Performance curves

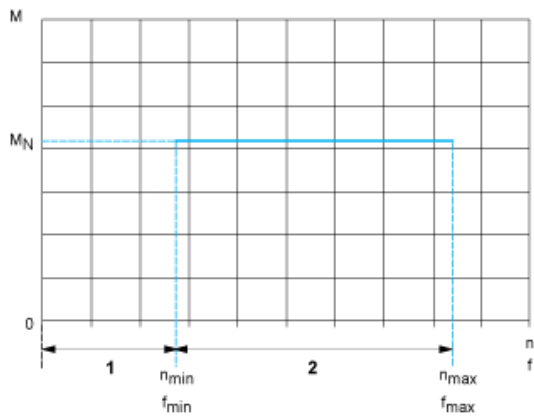

- M : Torque in Nm
- n : Speed in rpm
- f : frequency in Hz
- 1 : Only permissible during acceleration and deceleration phases.
- 2 : Continuous operation with the default values from the configuration file.