



## Main

Range of Product	Harmony SCU
Product or Component Type	Small touch HMI controller
Display size	3.5 inch
Display type	Backlit LED colour TFT LCD
Touch panel	Analogue
Device presentation	Complete product

## Complementary

Display Resolution	320 x 240 pixels QVGA
Backlight lifespan	50000 hours 65000 colours
Brightness	16 levels via touch panel
View angle horiz x vert	60° left 60° right 40° top 60° bottom
Character font	Japanese (ANK, Kanji) ASCII Taiwanese (traditional Chinese) Korean Chinese (simplified Chinese)
Supply	External source
[Us] rated supply voltage	24 V 20.4...28.8 V)DC
Immunity to microbreaks	10 ms
Inrush current	30 A
Power Consumption in W	15 W
Local signalling	No indicator
Number of pages	Limited by internal memory capacity
Software Designation	SoMachine
Operating System	Harmony
Processor name	CPU RISC
Processor frequency	333 MHz
Memory description	Flash NAND, 128 MB Internal data storage FRAM, 128 kB Application run DRAM, 128 MB
Integrated connection type	1 serial link - RJ45 - RS232/RS485 <= 115.2 kbits/s) 1 Ethernet TCP/IP - RJ45 1 USB 2.0 type mini B 1 USB 2.0 type A CANopen master bus - SUB-D 9
Realtime clock	Built-in
Downloadable protocols	CANopen Modbus TCP/IP Modbus
Fixing mode	By 1 nut Ø 22 mm 1...6 mm thick panel
Enclosure Material	PC/PBT
Shock resistance	147 m/s <sup>2</sup> 11 ms on DIN rail)IEC 60068-2-27 294 m/s <sup>2</sup> 6 ms on panel mounting)IEC 60068-2-27

The information provided in this documentation contains general descriptions and/or technical characteristics of the products contained herein. This documentation is not intended as a substitute for and is not to be used for determining suitability or reliability of these products for specific user applications. It is the duty of any such user or integrator to perform the appropriate and complete risk analysis, evaluation and testing of the products with respect to the relevant specific application or use thereof. Neither Schneider Electric Industries SAS nor any of its affiliates or subsidiaries shall be responsible or liable for misuse of the information contained herein.

Vibration resistance	+/- 3.5 mm 5...9 Hz) IEC 60068-2-6 1 gn 9...150 Hz) IEC 60068-2-6
Electromagnetic compatibility	Electrostatic discharge immunity test - test level: 8 kV (air discharge) conforming to IEC 61000-4-2 Electrostatic discharge immunity test - test level: 6 kV (contact discharge) conforming to IEC 61000-4-2 Susceptibility to electromagnetic fields - test level: 10 V/m (80 MHz...3 GHz) conforming to IEC 61000-4-3 Electrical fast transient/burst immunity test - test level: 2 kV (power lines) conforming to IEC 61000-4-4 Electrical fast transient/burst immunity test - test level: 1 kV (between analogue I/O and operating voltage) conforming to IEC 61000-4-4 Electrical fast transient/burst immunity test - test level: 2 kV (relay wires) conforming to IEC 61000-4-4 Electrical fast transient/burst immunity test - test level: 1 kV (Ethernet line) conforming to IEC 61000-4-4 Electrical fast transient/burst immunity test - test level: 1 kV (COM line) conforming to IEC 61000-4-4 Electrical fast transient/burst immunity test - test level: 1 kV (CAN line) conforming to IEC 61000-4-4 Surge immunity test - test level: 2 kV (power supply (common mode)) conforming to IEC 61000-4-5 Surge immunity test - test level: 1 kV (power supply (differential mode)) conforming to IEC 61000-4-5 Surge immunity test - test level: 1 kV common mode (digital I/O) conforming to IEC 61000-4-5 Surge immunity test - test level: 0.5 kV differential mode (digital I/O) conforming to IEC 61000-4-5 Conducted RF disturbances - test level: 10 V (0.15...80 MHz) conforming to IEC 61000-4-6 Conducted emission - test level: 150 kHz...30 MHz conforming to EN 55011 Radiated emission - test level: 30 MHz...1 GHz conforming to EN 55011
Discrete input number	2 fast input (normal mode) IEC 61131-2 Type 1 14 digital input IEC 61131-2 Type 1
Discrete input voltage	24 V DC sink or source (positive/negative)
Number of common point	1 fast input (HSC mode) 2 digital input
Discrete input current	7.83 MA fast input 5 mA digital
Input impedance	2.81 kOhm 4.7 kOhm
Sensor power supply	15...28.8 V DC >= 15 V >= 5 mA <= 5 V <= 1.5 mA 15...28.8 V DC >= 15 V >= 2.5 mA <= 5 V <= 1 mA
Configurable filtering time	0 ms no filter none) 0.004...0.04 ms bounce filter latch/event and cumulative filter by step Nx0.5ms (64>=N>=2)) 3...12 ms integrator none/run/stop)
Maximum input frequency	100 KHz fast input (encoder mode) A/B 100 KHz fast input single phase 100 kHz fast input pulse/direction
Maximum cable distance between devices	Shielded cable <32.81 ft (10 m) fast input Shielded cable <328.08 ft (100 m) digital input Unshielded cable <164.04 ft (50 m) digital input
Connection pitch	0.14 in (3.5 mm)
Overvoltage protection	With
Isolation between channels and internal logic	500 V DC
Isolation between channels	None
Discrete output number	2 fast output (normal mode) source 8 digital output source
Discrete output voltage	24 V DC 19.2...28.8 V)transistor 24 V DC 5...30 V)relay 220 V AC 100...250 V)relay
Input/output number	2 fast input FI0...FI1 14 digital input DI0...DI13 2 fast output FQ0...FQ1 8 digital output DQ0...DQ7
Discrete output current	2 A 4 A)5 ms opening contact digital output 2 A 4 A)2 ms closing contact digital output 300 mA2 ms fast output (normal mode) 50 mA2 ms fast output (PWM or PTO mode)
Insulation resistance	> 10 MOhm between the I/O and internal logic > 10 MOhm between power supply and earth

Maximum output frequency	100 KHz fast output (PTO mode) 1 kHz fast output (PWM mode)
Absolute accuracy error	+/- 0.1 % of full scale cyclic ratio 1...99% fast output (PWM or PTO mode) 1 % of full scale cyclic ratio 1...99% fast output (PWM or PTO mode) +/- 5 % of full scale cyclic ratio 10...90% fast output (PWM or PTO mode) +/- 10 % of full scale cyclic ratio 20...80% fast output (PWM or PTO mode) +/- 15 % of full scale cyclic ratio 30...70% fast output (PWM or PTO mode)
Height	2.95 in (74.95 mm)
Width	5.04 in (128 mm)
Depth	4.02 in (102 mm)
Net Weight	1.13 lb(US) (0.512 kg)

## Environment

Standards	IEC 61000-6-2 FCC Class A UL 508 EN 61131-2 CSA C22.2 No 213 Class I Division 2 ANSI/ISA 12-12-01
Product Certifications	cULus 508[RETURN]cUL 1604 Class 1 Division 2[RETURN]KCC[RETURN]C-tick[RETURN]cULus CSA 22-2 No 142[RETURN]GOST[RETURN]UKCA[RETURN]UKEX
Marking	CE
Ambient Air Temperature for Operation	32...122 °F (0...50 °C)
Ambient Air Temperature for Storage	-4...140 °F (-20...60 °C)
Relative humidity	5...85 % without condensation
Operating altitude	<= 6561.68 ft (2000 m)
Storage altitude	0.00...32808.40 ft (0...10000 m)
Maximum pressure	800...1114 hPa
IP degree of protection	IP20 IEC 60529 rear panel) IP65 IEC 60529 front panel)
NEMA degree of protection	NEMA 4X front panel
Pollution degree	2 IEC 60664
Environmental characteristic	Corrosive gas free

## Ordering and shipping details

Category	22568-HMI CONTROLLERS
Discount Schedule	MC2
GTIN	3595864175553
Returnability	Yes
Country of origin	CN

## Packing Units

Unit Type of Package 1	PCE
Number of Units in Package 1	1
Package 1 Height	7.24 in (18.4 cm)
Package 1 Width	4.25 in (10.8 cm)
Package 1 Length	10.51 in (26.7 cm)
Package 1 Weight	38.20 oz (1083 g)
Unit Type of Package 2	S03
Number of Units in Package 2	4
Package 2 Height	11.81 in (30 cm)
Package 2 Width	11.81 in (30 cm)
Package 2 Length	15.75 in (40 cm)
Package 2 Weight	9.84 lb(US) (4.464 kg)

## Offer Sustainability

Sustainable offer status	Green Premium product
California proposition 65	WARNING: This product can expose you to chemicals including: Lead and lead compounds, which is known to the State of California to cause cancer and birth defects or other reproductive harm. For more information go to <a href="http://www.P65Warnings.ca.gov">www.P65Warnings.ca.gov</a>
REACH Regulation	<a href="#">REACH Declaration</a>
EU RoHS Directive	Pro-active compliance (Product out of EU RoHS legal scope)
Mercury free	Yes
China RoHS Regulation	<a href="#">China RoHS Declaration</a>
RoHS exemption information	<a href="#">Yes</a>
Environmental Disclosure	<a href="#">Product Environmental Profile</a>
Circularity Profile	<a href="#">End Of Life Information</a>
WEEE	The product must be disposed on European Union markets following specific waste collection and never end up in rubbish bins.
Upgradeability	Upgradeable through digital modules and upgraded components

Dimensions

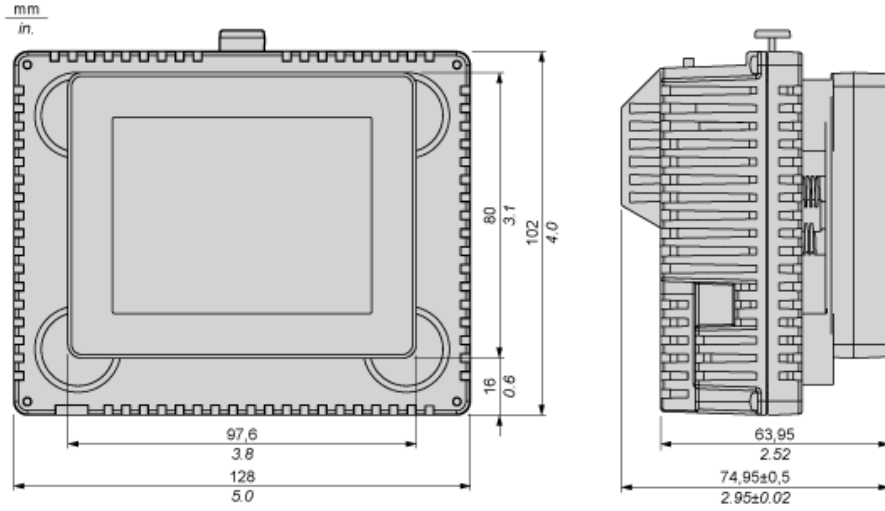

Recommended Mounting position

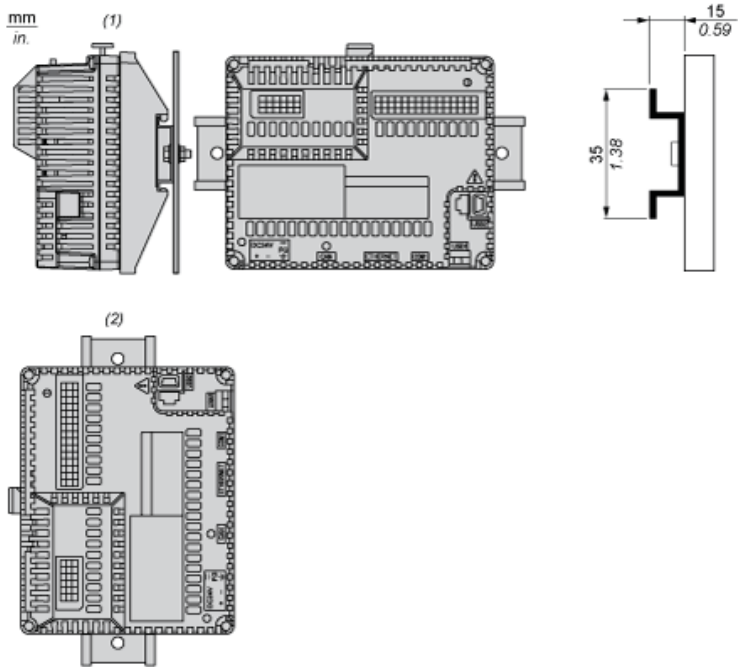

- (1) Horizontal mounting
- (2) Vertical mounting

No Recommended Mounting Position

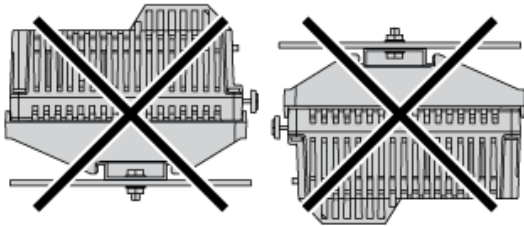

Mounting on a Slanted Panel

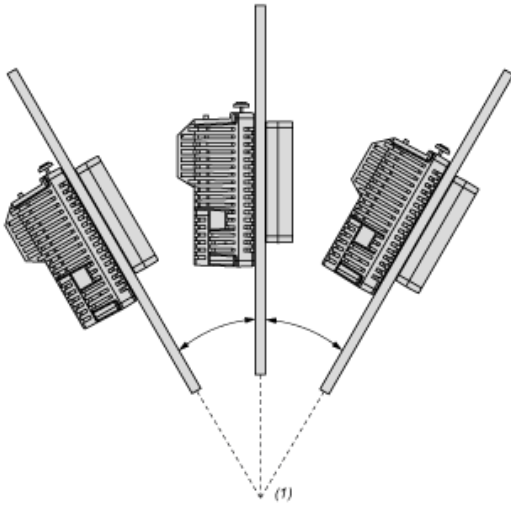

(1) 30° or less

## Clearance

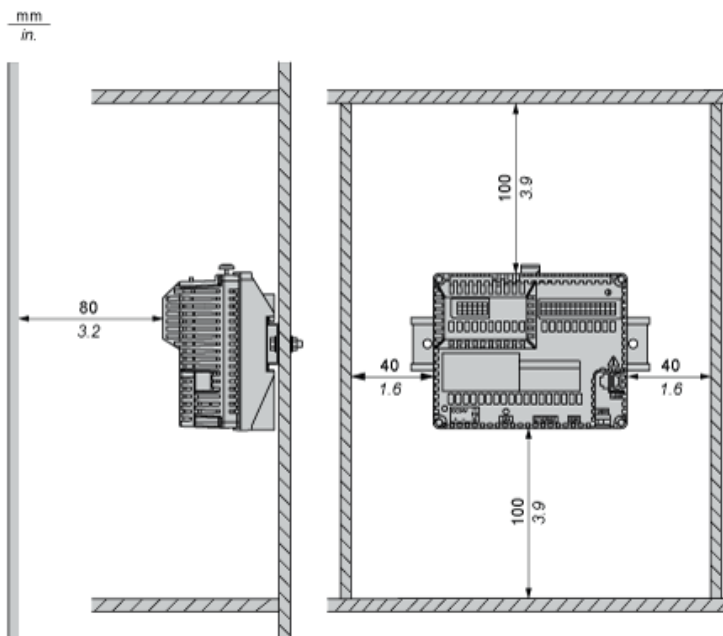

Keep adequate spacing for proper ventilation to maintain an ambient temperature between 0...50 °C (32...122 °F) for horizontal installation and 0...40 °C (32...104 °F) for vertical installation.

Wiring Diagram

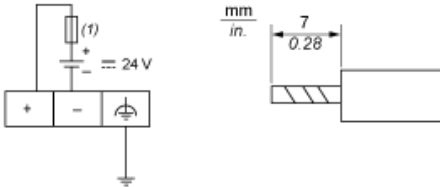

(1) Slow-blow 2A type T fuse

Wiring Diagram of Digital Inputs

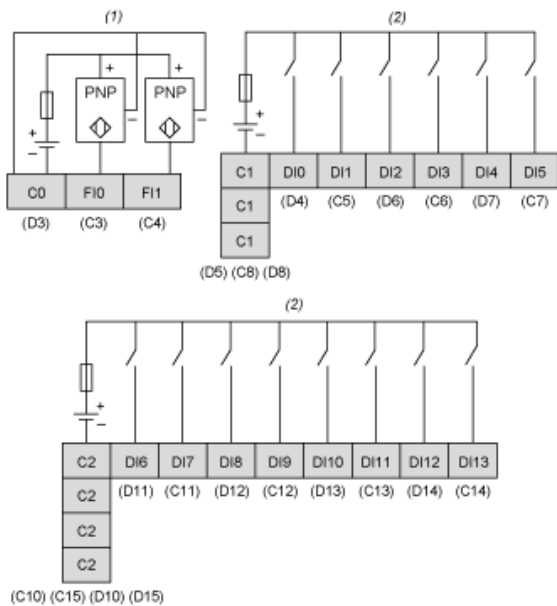

(1) HSC inputs with pin assignment of terminal blocks C,D.  
(2) Digital inputs with pin assignment of terminal blocks C,D.

Wiring Diagram of Digital Outputs

(1)

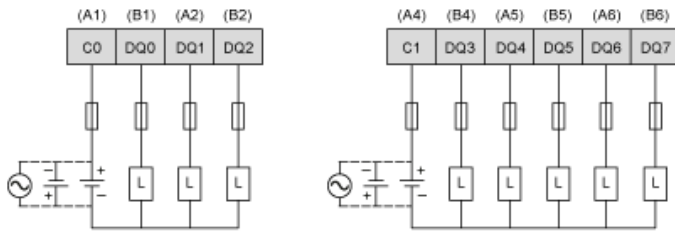

(2)

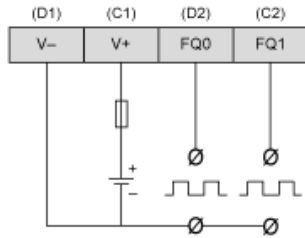

- (1) Digital outputs with pin assignment of terminal blocks A,B.
- (2) PWM outputs with pin assignment of terminal blocks C,D.
- (L) Load