



## Main

Product or Component Type	Motor choke
Range Compatibility	Altivar 212 Altivar 61 Altivar 71 Altivar&nbsp;Process ATV900 Altivar&nbsp;Process ATV600
Product Specific Application	Output filter
Line Rated Current	90 A

---

Product compatibility

ATV61H075N4  
ATV61HU15N4  
ATV61HU22N4  
ATV61HU30N4  
ATV61HU40N4  
ATV61W075N4  
ATV61W075N4C  
ATV61WU15N4  
ATV61WU15N4C  
ATV61WU22N4  
ATV61WU22N4C  
ATV61WU30N4  
ATV61WU30N4C  
ATV61WU40N4  
ATV61WU40N4C  
ATV71H075N4  
ATV71HU15N4  
ATV71HU22N4  
ATV71HU30N4  
ATV71HU40N4  
ATV71P075N4Z  
ATV71PU15N4Z  
ATV71PU22N4Z  
ATV71PU30N4Z  
ATV71PU40N4Z  
ATV71W075N4  
ATV71WU15N4  
ATV71WU22N4  
ATV71WU30N4  
ATV71WU40N4  
ATV61HD11N4  
ATV61HD11Y  
ATV61HD15N4  
ATV61HD18N4  
ATV61HU22S6X  
ATV61HU30M3  
ATV61HU30S6X  
ATV61HU30Y  
ATV61HU40M3  
ATV61HU40S6X  
ATV61HU40Y  
ATV61HU55M3  
ATV61HU55N4  
ATV61HU55S6X  
ATV61HU55Y  
ATV61HU75M3  
ATV61HU75N4  
ATV61HU75S6X  
ATV61HU75Y  
ATV61WD11N4  
ATV61WD11N4C  
ATV61WD15N4  
ATV61WD15N4C  
ATV61WD18N4  
ATV61WD18N4C  
ATV61WU55N4  
ATV61WU55N4C  
ATV61WU75N4  
ATV61WU75N4C  
ATV71HD11N4  
ATV71HD11Y  
ATV71HD15N4  
ATV71HD18N4  
ATV71HU15S6X  
ATV71HU22S6X  
ATV71HU22Y  
ATV71HU30M3  
ATV71HU30S6X  
ATV71HU30Y  
ATV71HU40M3  
ATV71HU40S6X  
ATV71HU40Y  
ATV71HU55M3  
ATV71HU55N4  
ATV71HU55S6X  
ATV71HU55Y  
ATV71HU75M3  
ATV71HU75N4  
ATV71HU75S6X  
ATV71HU75Y  
ATV71PD11N4Z  
ATV71PU55N4Z  
ATV71PU75N4Z  
ATV71WD11N4  
ATV71WD15N4

Sale per indivisible quantity	1
Electrical connection	Bare wires 0.35 in (9 mm)

## Complementary

Maximum motor cable length	984.25 Ft (300 m) shielded cable 2.2...7.5 kW 200...240 V 1 984.25 Ft (300 m) unshielded cable 2.2...7.5 kW 200...240 V 1 492.13 Ft (150 m) shielded cable 11...22 kW 200...240 V 1 984.25 Ft (300 m) unshielded cable 11...22 kW 200...240 V 1 524.93 Ft (160 m) shielded cable 0.75...18.5 kW 380...480 V 1 656.17 Ft (200 m) unshielded cable 0.75...18.5 kW 380...480 V 1 459.32 Ft (140 m) shielded cable 22...30 kW 380...480 V 1 557.74 Ft (170 m) unshielded cable 22...30 kW 380...480 V 1 246.06 Ft (75 m) shielded cable 2.2...7.5 kW 500...600 V 1 492.13 Ft (150 m) unshielded cable 2.2...7.5 kW 500...600 V 1 213.25 Ft (65 m) shielded cable 2.2...30 kW 500...690 V 1 328.08 Ft (100 m) unshielded cable 2.2...30 kW 500...690 V 1 492.13 Ft (150 m) shielded cable 2.2...7.5 kW 500...690 V 2 820.21 Ft (250 m) unshielded cable 2.2...7.5 kW 500...690 V 2 328.08 Ft (100 m) shielded cable 2.2...30 kW 500...690 V 2 492.13 Ft (150 m) unshielded cable 2.2...30 kW 500...690 V 2 318.24 Ft (97 m) shielded cable 37 kW 380...480 V 1 544.62 ft (166 m) unshielded cable 37 kW 380...480 V 1
DV/dt	500 V/μs 400 V 750 V/μs 500 V 1000 V/μs 690 V
Thermal losses	350 W
Maximum output frequency	100 Hz
Protection type	Thermal protection temperature-controlled switch 125 °C 250 V AC, <0.5 A
Ambient air temperature for operation	14...122 °F (-10...50 °C)
Net Weight	22.05 lb(US) (10 kg)

## Environment

IP degree of protection	IP20 with kits VW3A9612,613 IP00
Ambient Air Temperature for Storage	-13...158 °F (-25...70 °C)

## Packing Units

Unit Type of Package 1	PCE
Number of Units in Package 1	1
Package 1 Height	11.02 in (28.000 cm)
Package 1 Width	10.43 in (26.500 cm)
Package 1 Length	11.02 in (28.000 cm)
Package 1 Weight	21.41 lb(US) (9.711 kg)
Unit Type of Package 2	P06
Number of Units in Package 2	8
Package 2 Height	29.53 in (75.000 cm)
Package 2 Width	23.62 in (60.000 cm)
Package 2 Length	31.50 in (80.000 cm)
Package 2 Weight	200.22 lb(US) (90.816 kg)

## Offer Sustainability

REACH Regulation	<a href="#">REACH Declaration</a>
REACH free of SVHC	Yes
EU RoHS Directive	Pro-active compliance (Product out of EU RoHS legal scope) <a href="#">EU RoHS Declaration</a>
Toxic heavy metal free	Yes
Mercury free	Yes
China RoHS Regulation	<a href="#">China RoHS Declaration</a>
RoHS exemption information	<a href="#">Yes</a>

Dimensions

Right and Front View

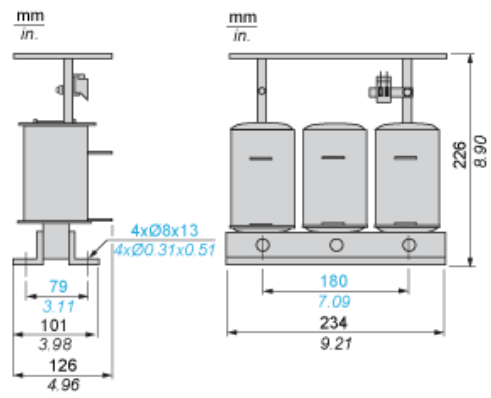

---

Mounting Recommendations

---

