

OTP-C Champagne Ductless Single Zone Heat Pump



Indoor Unit



Outdoor Unit



Performance up to



-18°C

Cooling



-25°C

Heating

Up to

23 SEER
IN COOLING

11 HSPF
IN HEATING



Features

Operation mode

- Cooling, heating, dehumidifying, fan and auto.

Nominal capacity

- 9000, 12000, 18000, 24000 BTU/hr.

Voltage

- 230/208V, 60 Hz, 1-phase.

Indoor unit

- High wall installation, dual side connection.
- Plastic housing, standard white.
- 4-speed cross-flow fan (turbo, high, medium and low).
- Washable filters.

Outdoor unit

- Variable speed rotary compressor (INVERTER), with overload protection.
- Electronic expansion valve for precise control of refrigerant flow.
- Condenser fins covered with a hydrophilic coating for improved corrosion resistance.
- Large diameter quiet axial-flow fan for more efficient heat exchange.
- Smart pan heater to prevent ice formation.
- Compressor blanket and preheating technology.
- Installation on epoxy/polyester powder coated adjustable steel wall bracket (optional).

Connection piping

- Minimum piping length of 10 ft. (3 m).
- Flared connections.

Control

- Wireless remote included.
- Wired wall controller available.
- Wi-Fi capability (option KIT-WIFI required).
- Set temperature: 16 to 30 °C (61 to 86 °F).
- Temperature display format: °C or °F.

Warranty

Note: All heat pump systems must be installed and registered by a certified Ouellet installer to be covered by the basic warranty.

- 5-year basic warranty on parts and 5-year basic warranty on the compressor (labour not included).

Sold separately:

- Extended warranty from the 1st to 5th year, parts and labour.
- Extended warranty from the 1st to 10th year, parts and labour with system replacement if the compressor fails.

Application

- Dining room-kitchen, living room, family room, commercial building, office building, condo, restaurant.

Includes



Smart Pan Heater



Crankcase Heater



Fin Coating



Quiet Design



Smart Defrosting



Smart Preheating



Auto Restart



Auto-Clean



Self-Diagnosis



Sleep Mode



Turbo Mode



Up & Down Swing



Timer



I Feel



Lock



Wireless Remote

Optional



Wall Controller



Wi-Fi

Product # ¹	Indoor Unit Outdoor Unit	OCD09KCH235-I OCD09KCH235-O	OCD12KCH225-I OCD12KCH225-O	OCD18KCH205-I OCD18KCH205-O	OCD24KCH205-I OCD24KCH205-O
------------------------	-----------------------------	--------------------------------	--------------------------------	--------------------------------	--------------------------------

Technical Performance

Voltage		Volts	230/208	230/208	230/208	230/208
Cooling capacity	Nominal	W (BTU/hr)	2638 (9000)	3517 (12000)	5275 (18000)	6448 (22000)
	Min. – max.	W (BTU/hr)	909 - 2813 (3100 - 9600)	909 - 3810 (3100 - 13000)	1993 - 5861 (6800 - 20000)	2000 - 8000 (6824 - 27296)
Heating capacity	Nominal	W (BTU/hr)	3224 (11000)	3810 (13000)	5803 (19800)	6741 (23000)
	Min. – max.	W (BTU/hr)	560 - 3517 (1911 - 12000)	703 - 4103 (2400 - 14000)	2151 - 6887 (7340 - 23500)	2000 - 9000 (6824 - 30708)
Used cooling power input	Nominal	W	630	960	1435	1830
	Min. – max.	W	160 - 1300	200 - 1350	450 - 2150	450 - 3000
Used heating power input	Nominal	W	1020	1100	1730	2000
	Min. – max.	W	160-1350	400 - 1400	580 - 2600	450 - 3000
Used rated input		W	1350	1400	2600	3000
Rated current		A	6.0	6.3	11.5	14.5
MCA		A	9	9	16	20
Max. over-current protection (MOCP)		A	15	15	25	30
SEER		-	23	22	20	20
HSPF		-	10.5	11	10.5	10
EER		(BTU/hr)/W	14.3	12.5	12.5	12.5
COP		W/W	3.16	3.46	3.35	3.37
ENERGY STAR		-	✓	✓	✓	✓

Indoor Unit

Dehumidification		pt/hr (l/hr)	1.69 (0.80)	2.96 (1.4)	3.8 (1.80)	4.23 (2.00)
Air flow volume	T / H / M / L ²	cfm	377 / 288 / 241 / 171	400 / 288 / 241 / 171	559 / 488 / 412 / 335	706 / 647 / 589 / 530
Sound level	T / H / M / L ²	dB (A)	43 / 39 / 35 / 29	45 / 39 / 35 / 29	47 / 43 / 40 / 39	48 / 44 / 40 / 36
Fan motor power output		W	20	20	60	60
Fan motor RLA		A	0.09	0.09	0.24	0.38
Deflector stepper motor power output		W	1.5	1.5	2.5	2.5
Net weight		lb (kg)	22 (10)	22 (10)	28 (13)	34 (15)

Outdoor Unit

Air flow volume		cfm	1059	2000	3200	2354
Sound level		dB (A)	53	54	55	59
Compressor power input		W	845	845	1440	2550
Compressor LRA		A	-	-	25	25
Compressor RLA		A	4	4	12.08	11.5
Fan motor power output		W	30	30	60	92
Fan motor RLA		A	-	-	0.49	0.65
Refrigerant volume (R410A)		oz (g)	45.9 (1301)	47.6 (1349)	56.44 (1600)	77.6 (2200)
Net weight		lb (kg)	78 (35)	86 (39)	106 (48)	142 (64)
Operating ambient temperature	Cooling	°C (°F)			-18 to 46 (0 to 115)	
	Heating	°C (°F)			-25 to 24 (-13 to 75)	

Connection Piping/Refrigerant

Pre-charge length		ft. (m)	25 (7.5)	25 (7.5)	25 (7.5)	25 (7.5)
Additional refrigerant charge		oz/ft. (g/m)	0.2 (18.6)	0.2 (18.6)	0.2 (18.6)	0.5 (46.5)
Liquid pipe outer diameter		in.	1/4	1/4	1/4	1/4
Gas pipe outer diameter		in.	3/8	1/2	5/8	5/8
Maximum height difference		ft. (m)	33 (10)	33 (10)	33 (10)	33 (10)
Maximum total length		ft. (m)	49 (15)	66 (20)	82 (25)	82 (25)

¹ 1 indoor unit and 1 outdoor unit. Note that each unit is individually packaged.

² Cross-Flow Fan Speeds: (T) Turbo / (H) High / (M) Medium / (L) Low.

Options

Product # Kit	Description
OTP-WB3	Adjustable wall bracket for outdoor unit
OTP-WBRC	Wall bracket for wireless remote
KIT-WIFI	Wi-Fi kit
OTP-XK76	Programmable wired wall controller

Capacity Variation Ratio According to Temperature

OCD09 & OCD12

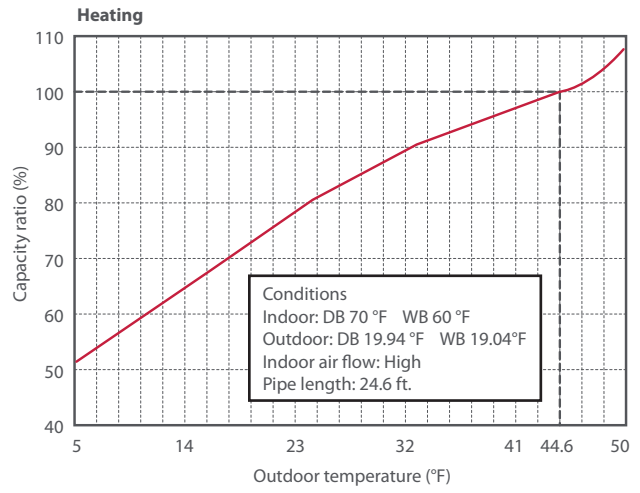
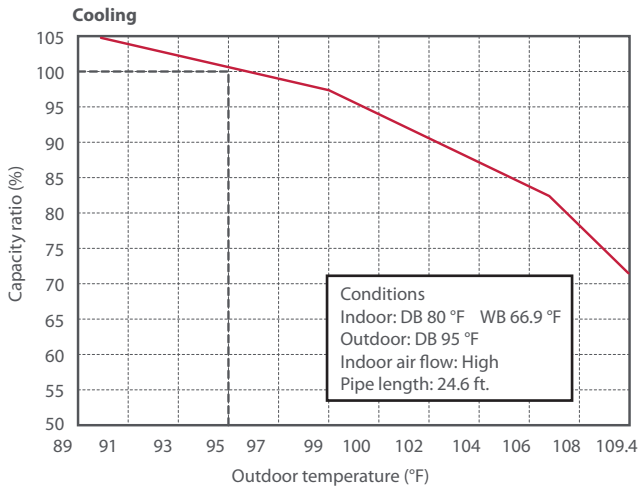

OCD18 & OCD24

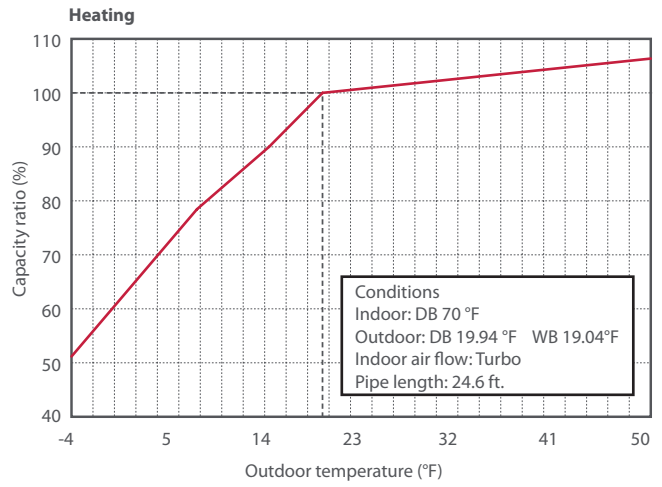
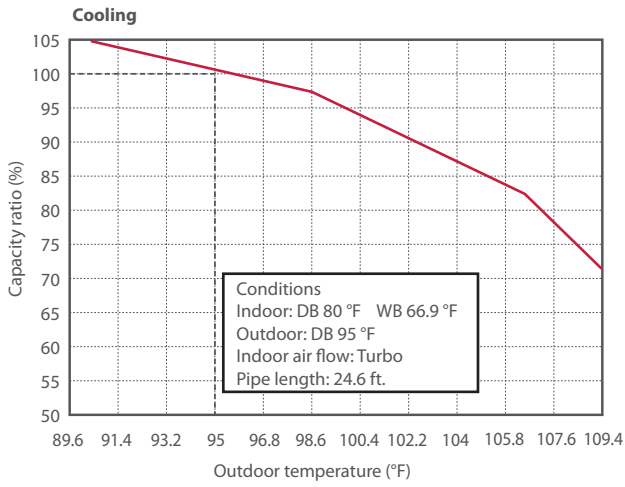

Indoor Unit

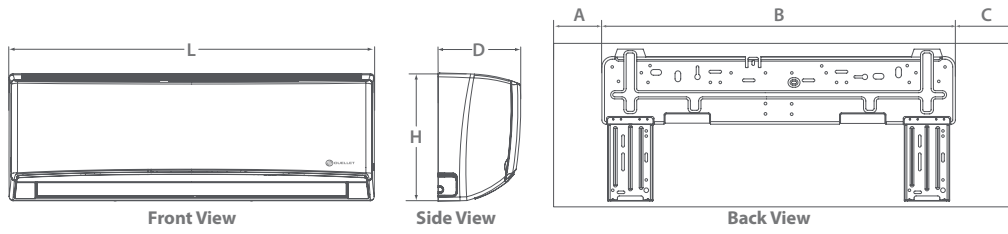

Outdoor Unit

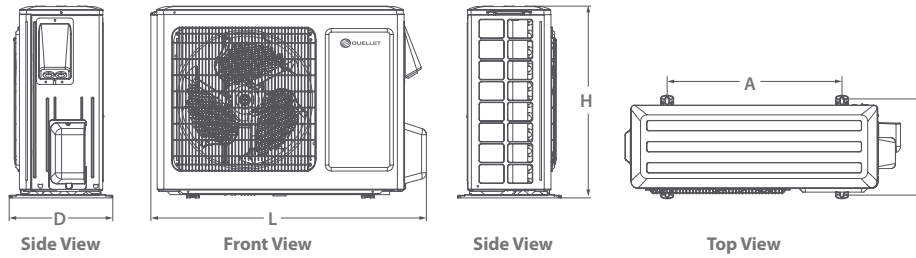

Adjustable Wall Bracket for Outdoor Unit

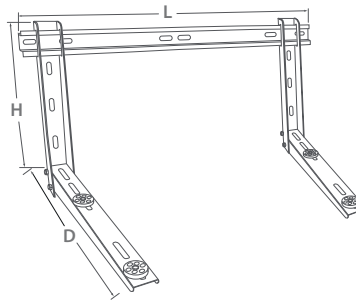

Indoor Unit	L		H		D		A		B		C	
	in.	mm	in.	mm	in.	mm	in.	mm	in.	mm	in.	mm
OCD09KCH23S-I OCD12KCH22S-I	33 1/4	845	11 3/8	289	8 1/4	209	4 11/16	119	21 5/16	542	7 1/4	184
OCD18KCH20S-I	38 3/16	970	11 13/16	300	8 13/16	224	4	102	27	686	7 3/16	183
OCD24KCH20S-I	42 7/16	1078	12 13/16	325	9 11/16	246	8 1/8	206	27	686	7 5/16	186

Outdoor Unit	L		H		D		A		B	
	in.	mm	in.	mm	in.	mm	in.	mm	in.	mm
OCD09KCH23S-O	33 3/8	848	21 1/4	540	12 5/8	320	21 1/4	540	11 1/4	286
OCD12KCH22S-O	33 3/8	848	23 5/16	592	12 5/8	320	21 1/4	540	11 1/4	286
OCD18KCH20S-O	37 5/8	955	27 9/16	700	15 9/16	396	22	559	14 5/16	364
OCD24KCH20S-O	38 9/16	980	31 1/8	790	16 13/16	427	24	610	15 9/16	395

Adjustable Wall Bracket	L		H		D		Maximum Capacity	
	in.	mm	in.	mm	in.	mm	lb	kg
OTP-WB3	33 1/2	850	17 3/4	450	21 11/16	550	500	227