

# BCH2MR3013CF6C

servo motor BCH, Lexium 28, 180mm, 3000W, 54.1kg.cm<sup>2</sup>, with oil seal, with key, brake, straight connection



## Main

Range Compatibility	Lexium 28
Product or Component Type	Servo motor
Device short name	BCH2

## Complementary

Maximum mechanical speed	3000 rpm
[Us] rated supply voltage	220 V
Phase	Three phase
Continuous stall current	16.49 A
Continuous stall torque	169.05 Lbf.in (19.1 N.m) LXM26D 19.8 A, 220 V, three phase 169.05 lbf.in (19.1 N.m) LXM28... 19.8 A, 220 V, three phase
Continuous power	3000 W
Peak stall torque	507.06 Lbf.in (57.29 N.m) LXM26D 19.8 A, 220 V, three phase 507.06 lbf.in (57.29 N.m) LXM28... 19.8 A, 220 V, three phase
Nominal output power	3000 W LXM26D 19.8 A, 220 V, three phase 3000 W LXM28... 19.8 A, 220 V, three phase
Nominal torque	169.05 Lbf.in (19.1 N.m) LXM26D 19.8 A, 220 V, three phase 169.05 lbf.in (19.1 N.m) LXM28... 19.8 A, 220 V, three phase
Nominal speed	1500 rpm LXM26D 19.8 A, 220 V, three phase 1500 rpm LXM28... 19.8 A, 220 V, three phase
Maximum current Irms	58.4 A LXM26D 3 kW, 220 V 58.4 A LXM28... 3 kW, 220 V
Maximum permanent current	18.8 A
Product compatibility	LXM26D servo drive 3 kW, 220 V, three phase LXM28... servo drive 3 kW, 220 V, three phase
Shaft end	Keyed
Shaft diameter	1.38 in (35 mm)
Shaft length	3.11 in (79 mm)
Key width	0.39 in (10 mm)
Feedback type	20 bits single turn absolute encoder
Holding brake	With
Holding torque	424.84 lbf.in (48 N.m) built-in
Mounting Support	Asian standard flange
Motor flange size	7.09 in (180 mm)
Electrical connection	Connector MIL
Torque constant	1.16 N.m/A 68 °F (20 °C)
Back emf constant	70 V/krpm 68 °F (20 °C)
Rotor inertia	54.1 kg.cm <sup>2</sup>
Stator resistance	0.234 Ohm 68 °F (20 °C)
Stator inductance	4.9 mH 68 °F (20 °C)

Stator electrical time constant	20.94 ms 68 °F (20 °C)
Maximum radial force Fr	1200 N 1500 rpm
Maximum axial force Fa	497 N
Brake pull-in power	49.6 W
Type of cooling	Natural convection
Length	9.25 in (235 mm)
Number of motor stacks	2
Centring collar diameter	4.50 in (114.3 mm)
Centring collar depth	0.16 in (4 mm)
Number of mounting holes	4
Mounting holes diameter	0.53 in (13.5 mm)
Circle diameter of the mounting holes	7.87 in (200 mm)
Distance shaft shoulder-flange	0.16 in (4 mm)
Net Weight	50.71 lb(US) (23 kg)

## Environment

IP Degree of Protection	IP50 IM V3 IP65 IM B5, IM V1
Ambient Air Temperature for Operation	32...104 °F (0...40 °C)

## Ordering and shipping details

Category	18281-LEXIUM 23/28 MOTORS
Discount Schedule	PC53
GTIN	3606480734991
Returnability	No
Country of origin	CN

## Packing Units

Unit Type of Package 1	PCE
Number of Units in Package 1	1
Package 1 Height	9.65 in (24.5 cm)
Package 1 Width	11.42 in (29 cm)
Package 1 Length	23.03 in (58.5 cm)
Package 1 Weight	868.78 oz (24630 g)
Unit Type of Package 2	P06
Number of Units in Package 2	4
Package 2 Height	19.69 in (50 cm)
Package 2 Width	31.50 in (80 cm)
Package 2 Length	23.62 in (60 cm)
Package 2 Weight	236.82 lb(US) (107.42 kg)

## Offer Sustainability

Sustainable offer status	Green Premium product
California proposition 65	WARNING: This product can expose you to chemicals including: Lead and lead compounds, which is known to the State of California to cause cancer and birth defects or other reproductive harm. For more information go to <a href="http://www.P65Warnings.ca.gov">www.P65Warnings.ca.gov</a>
REACH Regulation	 <a href="#">REACH Declaration</a>
REACH free of SVHC	Yes
EU RoHS Directive	Pro-active compliance (Product out of EU RoHS legal scope)
Mercury free	Yes
China RoHS Regulation	 <a href="#">China RoHS Declaration</a>
RoHS exemption information	 <a href="#">Yes</a>
Environmental Disclosure	 <a href="#">Product Environmental Profile</a>

---

Circularity Profile	<a href="#">End Of Life Information</a>
WEEE	The product must be disposed on European Union markets following specific waste collection and never end up in rubbish bins.
PVC free	Yes

---

Dimensions

Dimensions of Motor

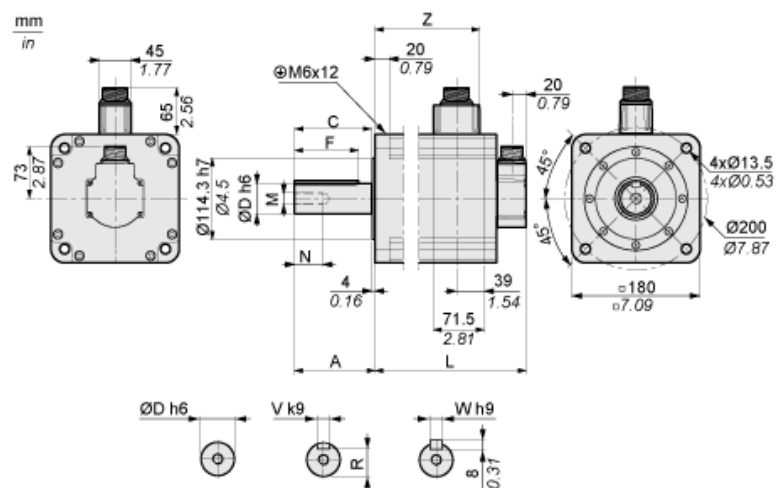

	mm	in.
L (without holding brake)	202	7.95
L (with holding brake)	235	9.25
A	79	3.11
C	73	2.87
D	35	1.38
F	63	2.48
N	28	1.10
M	M12	
R	30	1.18
V	10	0.39
W	10	0.39
Z	136	5.35

Torque/Speed Curves with 230 V Three Phase Supply Voltage

Servo Motor with LXM28AU30●●● Servo Drive

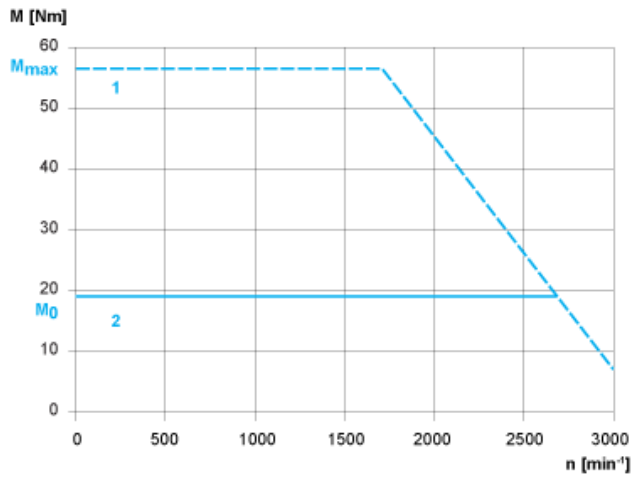

- 1 : Peak torque
- 2 : Continuous torque