

# Filter Fans (24...700)m<sup>3</sup>/h and Exhaust Filters

7F  
SERIES



Drying kilns



Textile machines



Machines  
for paper  
processing



Machines  
for ceramics



Wood-  
processing  
machines



Panels for  
electrical  
distribution



Control panels



Forced-air  
ventilators





**Filter Fans for electrical cabinets and enclosures 120 V or 230 V AC versions**

**Types 7F.20** for indoor use

**Types 7F.30** for outdoor use

- Very low acoustic noise
- Minimal depth within enclosure
- Nominal voltage: 120 or 230 V AC (50/60 Hz)
- Time-saving installation and maintenance
- Easily replaceable filter mat
- Filter Fan supplied in Reverse flow mode (7F.21 for indoor use, 7F.31 for outdoor use)
- Black colour RAL 9004 Available (only for 7F.2x)

7F.x0.8.xxx.xxxx  
Push-in terminal



**7F.20.8.xxx.1020**  
**7F.30.8.xxx.1020**



- Nominal voltage 120 or 230 V AC
- Air volume 50/60 Hz: 24/29 m<sup>3</sup>/h
- Size 1

**7F.20.8.xxx.2055**  
**7F.30.8.xxx.2055**



- Nominal voltage 120 or 230 V AC
- Air volume 50/60 Hz: 55/63 m<sup>3</sup>/h
- Size 2

**7F.20.8.xxx.3100**  
**7F.30.8.xxx.3100**



- Nominal voltage 120 or 230 V AC
- Air volume 50/60 Hz: 100/115 m<sup>3</sup>/h
- Size 3

For outline drawing see page 14

**Fan data**

Air volume (free flow): 50/60 Hz	m <sup>3</sup> /h	24/29		55/63		100/115	
Air volume (with exhaust filter installed): 50/60 Hz	m <sup>3</sup> /h	14/16.5		40/45.5		75/85.5	
Noise level	dB (A)	27		42		42	
Life time at 40 °C	h	50 000		50 000		50 000	

**Electrical data**

Nominal voltage (U <sub>N</sub> )	V AC (50/60 Hz)	120	230	120	230	120	230
Operating range	AC	(0...1.1)U <sub>N</sub>		(0.8...1.1)U <sub>N</sub>		(0.8...1.1)U <sub>N</sub>	
Current consumption: 50/60 Hz	A	0.23/0.18	0.1/0.08	0.25/0.21	0.13/0.11	0.25/0.21	0.13/0.11
Rated power: 50/60 Hz	W	27/21	23/18	30/25	29/25	30/25	29/25

**Other data**

Housing, cover	Plastics according to UL94 V-0						
Filter mat (included) EN 779	G3, filtering degree (80...90)%						
Filter mat (included) ISO 16890	ISO coarse 55%						
Filter material	Synthetic fibre with progressive construction, temperature resistant to +100 °C, self extinguishing, Class F1 (DIN 53438)						
Electrical connections	Push-in terminals						
Wire size (mm <sup>2</sup> )	min/max	0.7/2.5					
Wire size (AWG)	min/max	18/14					
Ambient temperature range	°C	-15...+55 (-30...+55 for 7F.3x)					
Protection category according to EN 60529	IP 54						
Protection category according to EN 62262	IK 08						
Protection category according to NEMA (7F.2x)	Type 12						
Protection category according to NEMA (7F.3x)	Type 3R						

**Approvals** (according to type)



**Filter Fans for electrical cabinets and enclosures 120 V or 230 V AC versions**

**Types 7F.20 for indoor use**

**Types 7F.30 for outdoor use**

- Very low acoustic noise
- Minimal depth within enclosure
- Nominal voltage: 120 or 230 V AC (50/60 Hz)
- Time-saving installation and maintenance
- Easily replaceable filter mat
- Filter Fan supplied in Reverse flow mode (7F.21 for indoor use, 7F.31 for outdoor use)
- Black colour RAL 9004 Available (only for 7F.2x)

7F.x0.8.xxx.4xxx  
Push-in terminal



**7F.20.8.xxx.4250**  
**7F.30.8.xxx.4250**



- Nominal voltage 120 or 230 V AC
- Air volume 50/60 Hz: 250/295 m<sup>3</sup>/h
- Size 4

**7F.20.8.xxx.4400**  
**7F.30.8.xxx.4400**



- Nominal voltage 120 or 230 V AC
- Air volume 50/60 Hz: 400/445 m<sup>3</sup>/h
- Size 4

G

For outline drawing see page 14, 15

Fan data					
Air volume (free flow): 50/60 Hz	m <sup>3</sup> /h	250/295		400/445	
Air volume (with exhaust filter installed): 50/60 Hz	m <sup>3</sup> /h	195/228		270/300	
Noise level	dB (A)	56		72	
Life time at 40 °C	h	50 000		50 000	
Electrical data					
Nominal voltage (U <sub>N</sub> )	V AC (50/60 Hz)	120	230	120	230
Operating range	AC	(0.8...1.1)U <sub>N</sub>		(0.8...1.1)U <sub>N</sub>	
Current consumption: 50/60 Hz	A	0.35/0.40	0.2/0.22	0.6/1	0.3/0.49
Rated power: 50/60 Hz	W	42/48	46/50	72/120	69/112
Other data					
Housing, cover		Plastics according to UL94 V-0			
Filter mat (included) EN 779		G3, filtering degree (80...90)%		G4, filtering degree (80...90)%	
Filter mat (included) ISO 16890		ISO coarse 55%		ISO coarse 75%	
Filter material		Synthetic fibre with progressive construction, temperature resistant to +100 °C, self extinguishing, Class F1 (DIN 53438)			
Electrical connections		Push-in terminals			
Wire size (mm <sup>2</sup> )	min/max	0.7/2.5			
Wire size (AWG)	min/max	18/14			
Ambient temperature range	°C	-15...+55 (-30...+55 for 7F.3x)			
Protection category according to EN 60529		IP 54			
Protection category according to EN 62262		IK 08			
Protection category according to NEMA (7F.2x)		Type 12			
Protection category according to NEMA (7F.3x)		Type 3R			
<b>Approvals</b> (according to type)					

**Filter Fans for electrical cabinets and enclosures 120 V or 230 V AC versions**

**Types 7F.20** for indoor use

**Types 7F.30** for outdoor use

- Very low acoustic noise
- Minimal depth within enclosure
- Nominal voltage: 120 or 230 V AC (50/60 Hz)
- Time-saving installation and maintenance
- Easily replaceable filter mat
- Filter Fan supplied in Reverse flow mode (7F.21 for indoor use, 7F.31 for outdoor use)
- Black colour RAL 9004 Available (only for 7F.2x)

7F.x0.8.xxx.5xx0  
Push-in terminal



**7F.20.8.xxx.5550**  
**7F.30.8.xxx.5550**



- Nominal voltage 120 or 230 V AC
- Air volume 50/60 Hz: 550/605 m<sup>3</sup>/h
- Size 5

**7F.20.8.xxx.5700**  
**7F.30.8.xxx.5700**



- Nominal voltage 120 or 230 V AC
- Air volume 50/60 Hz: 660/700 m<sup>3</sup>/h
- Size 5

For outline drawing see page 15

**Fan data**

Air volume (free flow): 50/60 Hz	m <sup>3</sup> /h	550/605		660/700	
Air volume (with exhaust filter installed): 50/60 Hz	m <sup>3</sup> /h	400/440		550/600	
Noise level	dB (A)	75		72	
Life time at 40 °C	h	50 000		50 000	

**Electrical data**

Nominal voltage (U <sub>N</sub> )	V AC (50/60 Hz)	120	230	120	230
Operating range	AC	(0.8...1.1)U <sub>N</sub>		(0.8...1.1)U <sub>N</sub>	
Current consumption: 50/60 Hz	A	0.66/0.85	0.34/0.49	0.92/1.14	0.46/0.53
Rated Power: 50/60 Hz	W	75/102	76/116	110/140	106/120

**Other data**

Housing, cover	Plastics according to UL94 V-0, light grey (RAL 7035)			
Filter mat (included) EN 779	G4, filtering degree (80...90)%		G3, filtering degree (80...90)%	
Filter mat (included) ISO 16890	ISO coarse 75%		ISO coarse 55%	
Filter material	Synthetic fibre with progressive construction, temperature resistant to +100 °C, self extinguishing, Class F1 (DIN 53438)			
Electrical connections	Push-in terminals			
Wire size (mm <sup>2</sup> )	min/max	0.7/2.5		
Wire size (AWG)	min/max	18/14		
Ambient temperature range	°C	-15...+55 (-30...+55 for 7F.3x)		
Protection category according to EN 60529	IP 54			
Protection category according to EN 62262	IK 08			
Protection category according to NEMA (7F.2x)	Type 12			
Protection category according to NEMA (7F.3x)	Type 3R			

**Approvals** (according to type)



**Filter Fans for electrical cabinets and enclosures 24 V DC versions**

**Types 7F.20 for indoor use**

**Types 7F.30 for outdoor use**

- Very low acoustic noise
- Minimal depth within enclosure
- Nominal voltage: 24 V DC
- Time-saving installation and maintenance
- Easily replaceable filter mat
- Filter Fan supplied in Reverse flow mode (7F.21 for indoor use, 7F.31 for outdoor use)
- Black colour RAL 9004 Available (only for 7F.2x)

7F.x0.9.024.xxxx  
Push-in terminal



**7F.20.9.024.1020**  
**7F.30.9.024.1020**



- Nominal voltage 24 V DC
- Air volume 24 m<sup>3</sup>/h
- Rated power 3.6 W
- Size 1

**7F.20.9.024.2055**  
**7F.30.9.024.2055**



- Nominal voltage 24 V DC
- Air volume 55 m<sup>3</sup>/h
- Rated power 7 W
- Size 2

**7F.20.9.024.3100**  
**7F.30.9.024.3100**



- Nominal voltage 24 V DC
- Air volume 100 m<sup>3</sup>/h
- Rated power 7 W
- Size 3

G

For outline drawing see page 14

**Fan data**

Air volume (free flow)	m <sup>3</sup> /h	24	55	100
Air volume (with exhaust filter installed)	m <sup>3</sup> /h	14	40	75
Noise level	dB (A)	37.5	46	45
Life time at 40 °C	h	50 000	50 000	50 000

**Electrical data**

Nominal voltage (U <sub>N</sub> )	V DC	24	24	24
Operating range	DC	(0.8...1.1)U <sub>N</sub>	(0.8...1.1)U <sub>N</sub>	(0.8...1.1)U <sub>N</sub>
Current consumption	A	0.15	0.32	0.32
Rated power	W	3.6	7	7

**Other data**

Housing, cover	Plastics according to UL94 V-0		
Filter mat (included) EN 779	G3, filtering degree (80...90)%		
Filter mat (included) ISO 16890	ISO coarse 55%		
Filter material	Synthetic fibre with progressive construction, temperature resistant to 100 °C, self extinguishing, Class F1 (DIN 53438)		
Electrical connections	Push-in terminals		
Wire size (mm <sup>2</sup> )	min/max	0.7/2.5	
Wire size (AWG)	min/max	18/14	
Ambient temperature range	°C	-15...+55 (-30...+55 for 7F.3x)	
Protection category according to EN 60529	IP 54		
Protection category according to EN 62262	IK 08		
Protection category according to NEMA (7F.2x)	Type 12		
Protection category according to NEMA (7F.3x)	Type 3R		

**Approvals** (according to type)



**Filter Fans for electrical cabinets and enclosures 24 V DC versions**

**Types 7F.20** for indoor use

**Types 7F.30** for outdoor use

- Very low acoustic noise
- Minimal depth within enclosure
- Nominal voltage: 24 V DC
- Time-saving installation and maintenance
- Easily replaceable filter mat
- Filter Fan supplied in Reverse flow mode (7F.21 for indoor use, 7F.31 for outdoor use)
- Black colour RAL 9004 Available (only for 7F.2x)

7F.x0.9.024.4250  
Push-in terminal



**7F.20.9.024.4250**

**7F.30.9.024.4250**



- Nominal voltage 24 V DC
- Air volume 250 m<sup>3</sup>/h
- Rated power 43 W
- Size 4

For outline drawing see page 14

Fan data		
Air volume (free flow)	m <sup>3</sup> /h	250
Air volume (with exhaust filter installed)	m <sup>3</sup> /h	195
Noise level	dB (A)	64
Life time at 40 °C	h	50 000
Electrical data		
Nominal voltage (U <sub>N</sub> )	V DC	24
Operating range	DC	(0.8...1.1)U <sub>N</sub>
Current consumption	A	1.8
Rated power	W	43
Other data		
Housing, cover		Plastics according to UL94 V-0
Filter mat (included) EN 779		G3, filtering degree (80...90)%
Filter mat (included) ISO 16890		ISO coarse 55%
Filter material		Synthetic fibre with progressive construction, temperature resistant to 100 °C, self extinguishing, Class F1 (DIN 53438)
Electrical connections		Push-in terminals
Wire size (mm <sup>2</sup> )	min/max	0.7/2.5
Wire size (AWG)	min/max	18/14
Ambient temperature range	°C	-15...+55 (-30...+55 for 7F.3x)
Protection category according to EN 60529		IP 54
Protection category according to EN 62262		IK 08
Protection category according to NEMA (7F.2x)		Type 12
Protection category according to NEMA (7F.3x)		Type 3R
<b>Approvals</b> (according to type)		

## Ordering information

Example: Series 7F, Filter Fan for mounting in sidewalls, nominal voltage 230 V AC, size 1, air volume 24 m<sup>3</sup>/h, for indoor use.

7 F . 2 0 . 8 . 2 3 0 . 1 0 2 0

<b>Series</b>	7 F												<b>Colour</b>
<b>Type</b>	20	0	8	2	3	0	1	0	2	0			Empty = Grey RAL 7035 (7F.2x) Grey RAL 7000 (7F.3x)
	20 = Filter Fan - for indoor use												0 = Black RAL 9004 (only for 7F.2x)
	21 = Reverse flow Filter Fan - for indoor use												7 = Grey RAL 7035 (only for 7F.3x)
	30 = Filter Fan - for outdoor use												
	31 = Reverse flow Filter Fan - for outdoor use												
<b>Supply version</b>													
	8 = AC (50/60 Hz)												
	9 = DC												
<b>Operating voltage</b>													
	024 = 24 V DC												
	120 = 120 V AC												
	230 = 230 V AC												
<b>Enclosure cut-out</b>													
	1 = Size 1 (92 <sup>+1.0</sup> x 92 <sup>+1.0</sup> ) mm												
	2 = Size 2 (125 <sup>+1.0</sup> x 125 <sup>+1.0</sup> ) mm												
	3 = Size 3 (177 <sup>-1.0</sup> x 177 <sup>-1.0</sup> ) mm												
	4 = Size 4 (223 <sup>+1.0</sup> x 223 <sup>+1.0</sup> ) mm												
	5 = Size 5 (291 <sup>+1.0</sup> x 291 <sup>+1.0</sup> ) mm												
<b>Nominal air volume (free flow)</b>													
	020 = 24 m <sup>3</sup> /h												
	055 = 55 m <sup>3</sup> /h												
	100 = 100 m <sup>3</sup> /h												
	250 = 250 m <sup>3</sup> /h												
	400 = 400 m <sup>3</sup> /h												
	550 = 550 m <sup>3</sup> /h												
	700 = 700 m <sup>3</sup> /h												

### Filter Fans - All versions

Standard indoor versions	Standard outdoor versions	Reverse flow indoor versions	Reverse flow outdoor versions	
7F.20.8.120.1020	7F.30.8.120.1020	7F.21.8.120.1020	7F.31.8.120.1020	Filter Fan, Size 1
7F.20.8.120.2055	7F.30.8.120.2055	7F.21.8.120.2055	7F.31.8.120.2055	Filter Fan, Size 2
7F.20.8.120.3100	7F.30.8.120.3100	7F.21.8.120.3100	7F.31.8.120.3100	Filter Fan, Size 3
7F.20.8.120.4250	7F.30.8.120.4250	7F.21.8.120.4250	7F.31.8.120.4250	Filter Fan, Size 4
7F.20.8.120.4400	7F.30.8.120.4400	7F.21.8.120.4400	7F.31.8.120.4400	Filter Fan, Size 4
7F.20.8.120.5550	7F.30.8.120.5550	7F.21.8.120.5550	7F.31.8.120.5550	Filter Fan, Size 5
7F.20.8.120.5700	7F.30.8.120.5700	7F.21.8.120.5700	7F.31.8.120.5700	Filter Fan, Size 5
7F.20.8.230.1020	7F.30.8.230.1020	7F.21.8.230.1020	7F.31.8.230.1020	Filter Fan, Size 1
7F.20.8.230.2055	7F.30.8.230.2055	7F.21.8.230.2055	7F.31.8.230.2055	Filter Fan, Size 2
7F.20.8.230.3100	7F.30.8.230.3100	7F.21.8.230.3100	7F.31.8.230.3100	Filter Fan, Size 3
7F.20.8.230.4250	7F.30.8.230.4250	7F.21.8.230.4250	7F.31.8.230.4250	Filter Fan, Size 4
7F.20.8.230.4400	7F.30.8.230.4400	7F.21.8.230.4400	7F.31.8.230.4400	Filter Fan, Size 4
7F.20.8.230.5550	7F.30.8.230.5550	7F.21.8.230.5550	7F.31.8.230.5550	Filter Fan, Size 5
7F.20.8.230.5700	7F.30.8.230.5700	7F.21.8.230.5700	7F.31.8.230.5700	Filter Fan, Size 5
7F.20.9.024.1020	7F.30.9.024.1020	7F.21.9.024.1020	7F.31.9.024.1020	Filter Fan, Size 1
7F.20.9.024.2055	7F.30.9.024.2055	7F.21.9.024.2055	7F.31.9.024.2055	Filter Fan, Size 2
7F.20.9.024.3100	7F.30.9.024.3100	7F.21.9.024.3100	7F.31.9.024.3100	Filter Fan, Size 3
7F.20.9.024.4250	7F.30.9.024.4250	7F.21.9.024.4250	7F.31.9.024.4250	Filter Fan, Size 4

Note:  
The technical features (air volume, dimensions and electrical parameters) for the Standard Filter Fans (7F.20 and 7F.30) and the Reverse flow versions (7F.21 and 7F.31) - are exactly the same.

**Exhaust Filters**

Types 7F.02 for indoor use

Types 7F.03 for outdoor use

The size of the Exhaust Filter should match the size of the Filter Fan to achieve the best ventilation within the cabinet

- Minimum depth within enclosure
- Time-saving installation and maintenance
- Easily replaceable filter mat
- Black colour RAL 9004 Available (only for 7F.02)

7F.02.0.000.1000  
7F.03.0.000.1000



- For Filter Fans 7F.20.x.xxx.1020 or 7F.30.x.xxx.1020
- Size 1

7F.02.0.000.2000  
7F.03.0.000.2000



- For Filter Fans 7F.20.x.xxx.2055 or 7F.30.x.xxx.2055
- Size 2

7F.02.0.000.3000  
7F.03.0.000.3000



- For Filter Fans 7F.20.x.xxx.3100 or 7F.30.x.xxx.3100
- Size 3

For outline drawing see page 14

**Other data**

Housing, cover	Plastics according to UL94 V-0
Filter mat EN 779	G3, filtering degree (80...90)%
Filter mat ISO 16890	ISO coarse 55%
Filter material	Synthetic fibre with progressive construction, temperature resistant to +100 °C, self extinguishing, Class F1 (DIN 53438)
Ambient temperature range °C	-15...+ 55 (-30...+55 for 7F.03)
Protection category according to EN 60529	IP 54
Protection category according to EN 62262	IK 08
Protection category according to NEMA (7F.02)	Type 12
Protection category according to NEMA (7F.03)	Type 3R
<b>Approvals</b> (according to type)	

**Exhaust Filters**

Types 7F.02 for **indoor** use

Types 7F.03 for **outdoor** use

The size of the Exhaust Filter should match the size of the Filter Fan to achieve the best ventilation within the cabinet

- Minimum depth within enclosure
- Time-saving installation and maintenance
- Easily replaceable filter mat
- Black colour RAL 9004 Available (only for 7F.02)

**7F.02.0.000.4000**  
**7F.03.0.000.4000**



- For Filter Fans  
7F.20.x.xxx.4250,  
7F.20.8.xxx.4440 or  
7F.30.x.xxx.4250,  
7F.30.8.xxx.4400
- Size 4

**7F.02.0.000.5000**  
**7F.03.0.000.5000**



- For Filter Fans  
7F.20.x.xxx.5550,  
7F.20.8.xxx.5700 or  
7F.30.x.xxx.5550,  
7F.30.8.xxx.5700
- Size 5

For outline drawing see page 15

**Other data**

Housing, cover	Plastics according to UL94 V-0, light grey (RAL 7035)
Filter mat EN 779	G3, filtering degree (80...90)%
Filter mat ISO 16890	ISO coarse 55%
Filter material	Synthetic fibre with progressive construction, temperature resistant to +100 °C, self extinguishing, Class F1 (DIN 53438)
Ambient temperature range °C	-15...+ 55 (-30...+55 for 7F.03)
Protection category according to EN 60529	IP 54
Protection category according to EN 62262	IK 08
Protection category according to NEMA (7F.02)	Type 12
Protection category according to NEMA (7F.03)	Type 3R
<b>Approvals</b> (according to type)	

### Ordering information

Example: Series 7F, Exhaust Filter for mounting in sidewalls, for indoor use, size 1.

<b>7</b>	<b>F</b>	<b>.</b>	<b>0</b>	<b>2</b>	<b>.</b>	<b>0</b>	<b>.</b>	<b>0</b>	<b>0</b>	<b>0</b>	<b>.</b>	<b>1</b>	<b>0</b>	<b>0</b>	<b>0</b>	<b>.</b>	<b> </b>
<b>Series</b>																	
<b>Type</b>																	
02 = Exhaust Filter - for indoor use																	
03 = Exhaust Filter - for outdoor use																	
<b>Supply and operating voltage</b>																	
0 = Not applicable for Exhaust Filter																	
<b>Operating voltage</b>																	
000 = Not applicable for Exhaust Filter																	
<b>Enclosure cut-out</b>																	
1000 = Size 1 (92 <sup>+1.0</sup> x 92 <sup>+1.0</sup> ) mm																	
2000 = Size 2 (125 <sup>+1.0</sup> x 125 <sup>+1.0</sup> ) mm																	
3000 = Size 3 (177 <sup>-1.0</sup> x 177 <sup>-1.0</sup> ) mm																	
4000 = Size 4 (223 <sup>+1.0</sup> x 223 <sup>+1.0</sup> ) mm																	
5000 = Size 5 (291 <sup>+1.0</sup> x 291 <sup>+1.0</sup> ) mm																	
<b>Colour</b>																	
Empty = Grey RAL 7035 (7F.02)																	
Grey RAL 7000 (7F.03)																	
0 = Black RAL 9004 (only for 7F.02)																	
7 = Grey RAL 7035 (only for 7F.03)																	

### Components

Standard Indoor Filter Fan	Standard Outdoor Filter Fan	Standard Indoor Exhaust Filter	Standard Outdoor Exhaust Filter	Filter mat	Size
7F.20.8.xxx.1020	7F.30.8.xxx.1020	7F.02.0.000.1000	7F.03.0.000.1000	07F.15	1
7F.20.8.xxx.2055	7F.30.8.xxx.2055	7F.02.0.000.2000	7F.03.0.000.2000	07F.25	2
7F.20.8.xxx.3100	7F.30.8.xxx.3100	7F.02.0.000.3000	7F.03.0.000.3000	07F.35	3
7F.20.8.xxx.4250	7F.30.8.xxx.4250	7F.02.0.000.4000	7F.03.0.000.4000	07F.45	4
7F.20.8.xxx.4400	7F.30.8.xxx.4400	7F.02.0.000.4000	7F.03.0.000.4000	07F.46 (07F.45 for 7F.0x-4000)	4
7F.20.8.xxx.5550	7F.30.8.xxx.5550	7F.02.0.000.5000	7F.03.0.000.5000	07F.56 (07F.55 for 7F.0x-5000)	5
7F.20.8.xxx.5700	7F.30.8.xxx.5700	7F.02.0.000.5000	7F.03.0.000.5000	07F.55	5
7F.20.9.024.1020	7F.30.9.024.1020	7F.02.0.000.1000	7F.03.0.000.1000	07F.15	1
7F.20.9.024.2055	7F.30.9.024.2055	7F.02.0.000.2000	7F.03.0.000.2000	07F.25	2
7F.20.9.024.3100	7F.30.9.024.3100	7F.02.0.000.3000	7F.03.0.000.3000	07F.35	3
7F.20.9.024.4250	7F.30.9.024.4250	7F.02.0.000.4000	7F.03.0.000.4000	07F.45	4

Spare Filter mats	07F.15	07F.25	07F.35	07F.45/46	07F.55/56
Protection category	IP 54				

### Accessories



07F.80

Pressure compensation device, for pressure compensation in closed cabinets or enclosures	07F.80
Air interface area	cm <sup>2</sup> 7
Mounting	PG 29 thread with union nut
Torque	Nm 5 (max. 10)
Material	plastic according to UL94-V0
Dimensions (diameter/depth)	mm 65.5/30.5
Mounting position	upper part of cabinet sidewalls
Ambient temperature	°C -45...+70
Protection category	IP 55

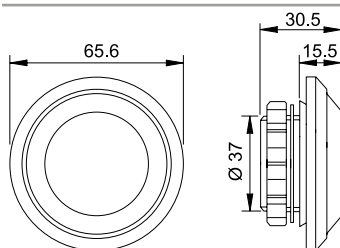

Unit package contains 2 pressure compensation devices

## Mounting instructions for Filter Fans

### Mounting arrangement of Filter Fans and Exhaust Filter

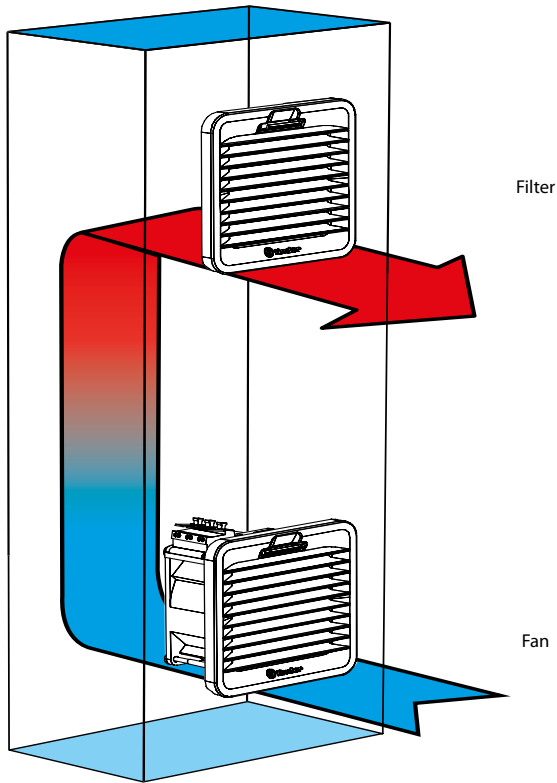

Filter

Fan

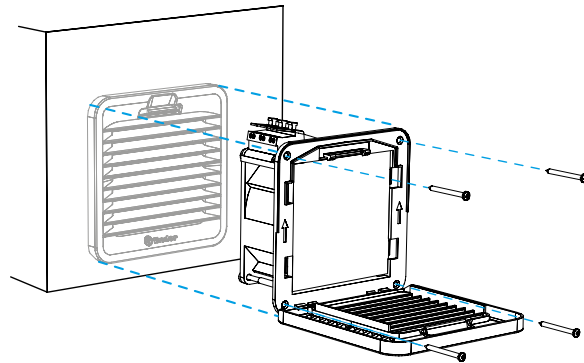

The installation with the only clips is optimized for 1.5 mm thick sheets; it is also possible with thicknesses from 1 to 2.5 mm. Fixing with screws (supplied) is recommended. Tightening torque 0.3 Nm.

## G

## Replacement of Filter mat

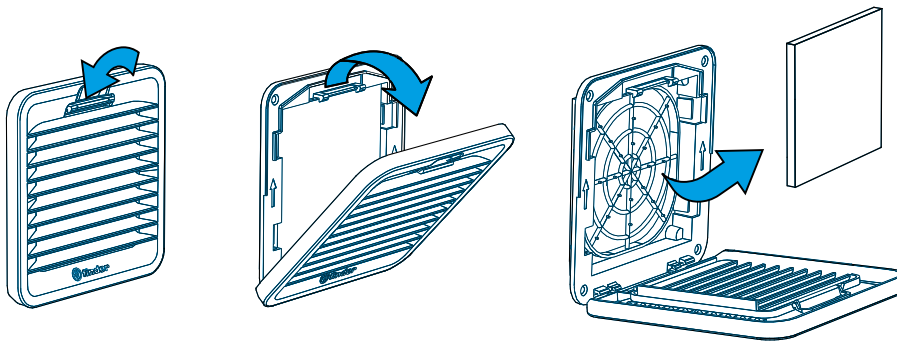

## Drilling template and mounting cut-outs for Filter Fans and Exhaust Filter

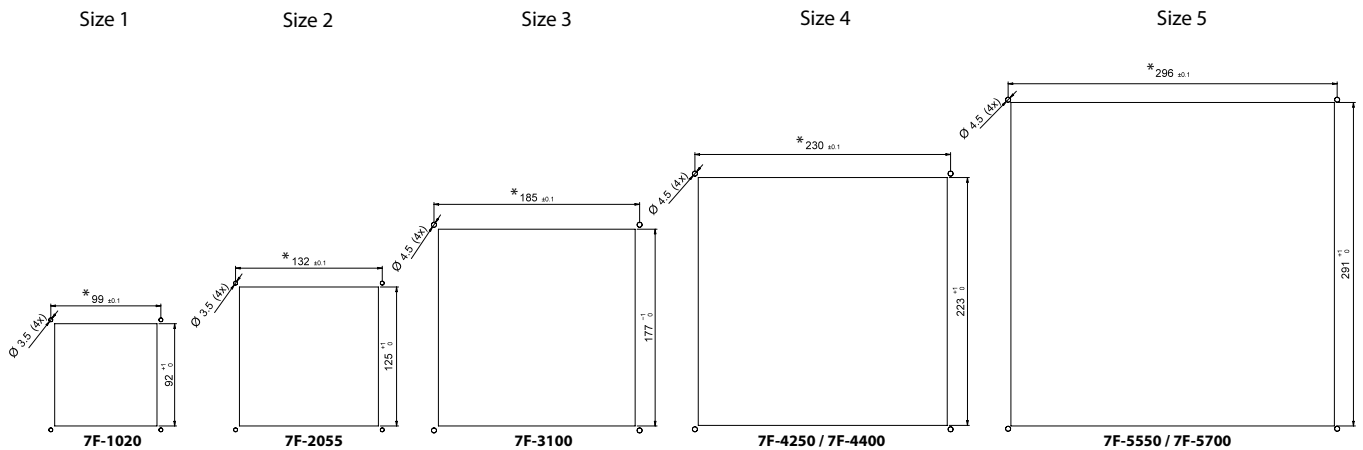

\* Distance between centres

### Mounting and maintenance

1. Make the panel cut-out according to the size of the Filter Fan or Exhaust Filter in the sidewall of the cabinet as appropriate.  
A template of the panel cut-out is included in the packaging of the Filter Fan or Exhaust Filter.
2. Make the electrical connection.
3. Mount by simply snapping the side-located lugs on the Filter Fan or Exhaust Filter into the panel cut-out (without using screws for sidewall thickness of 1.2...2.4 mm).  
At other thickness it is recommended to mount the Filter Fan by the screws supplied (for size 1, the template shows the mounting cut-out only).
4. When screws are needed for the mounting, remove the plastic cover and fix the Filter Fan with the 4 screws supplied.  
Then insert the filter mat and snap the plastic cover to the mounting frame.
5. During maintenance or when replacing the filter mat remove the plastic cover, replace the filter mat and snap on the plastic cover.

Outline drawings

Type 7F.xx.x.xxx.1020  
Push-in terminal

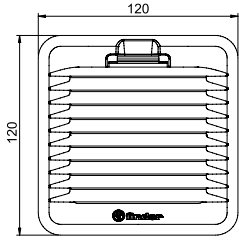

AC version

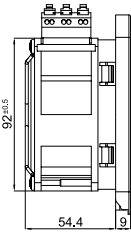

DC version

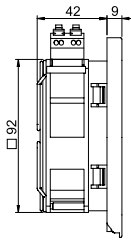

Type 7F.0x.0.000.1000

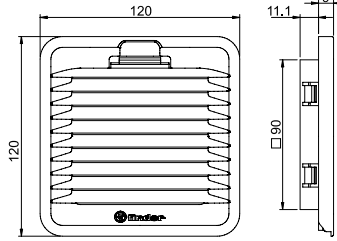

Type 7F.xx.x.xxx.2055  
Push-in terminal

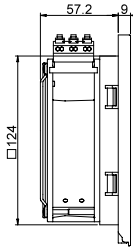
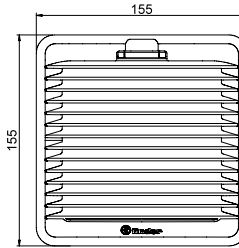

Type 7F.0x.0.000.2000

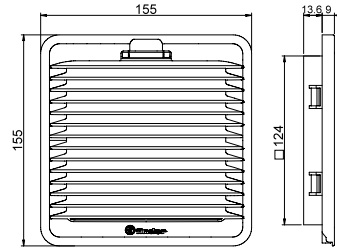

Type 7F.xx.x.xxx.3100  
Push-in terminal

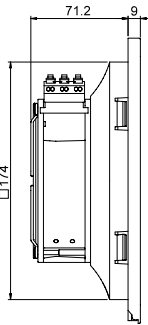
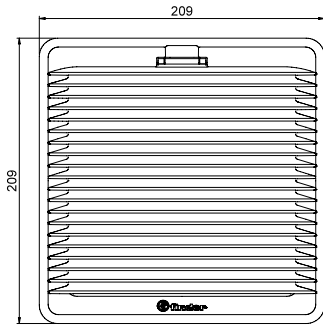

Type 7F.0x.0.000.3000

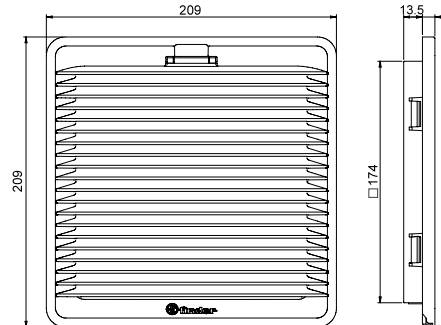

Type 7F.xx.x.xxx.4250  
Push-in terminal

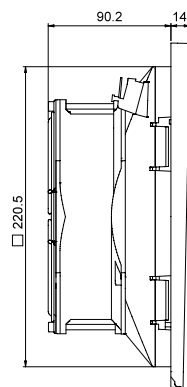
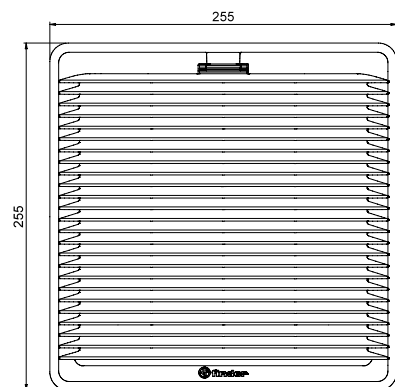

Type 7F.0x.0.000.4000

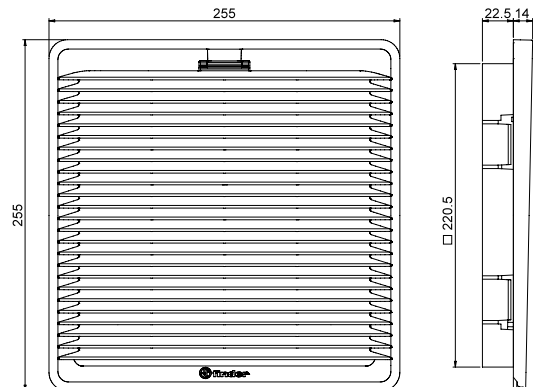

Outline drawings

Type 7F.xx.x.xxx.4400  
Push-in terminal

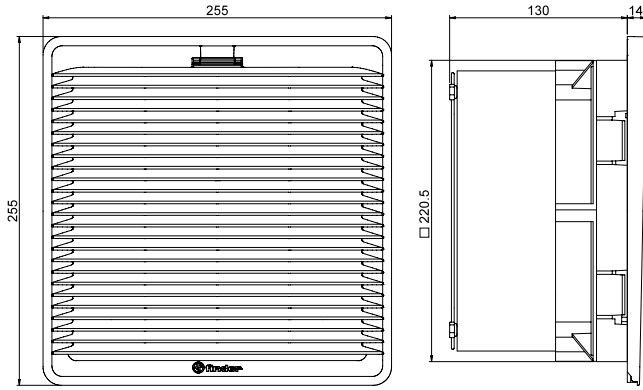

Type 7F.0x.0.000.4000

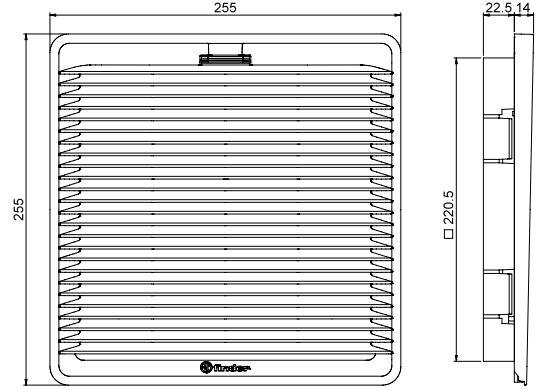

Type 7F.xx.x.xxx.5550  
Push-in terminal

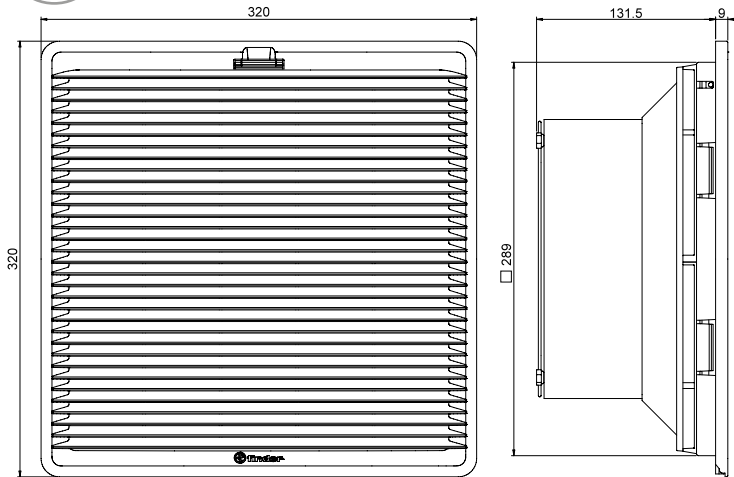

Type 7F.0x.0.000.5000

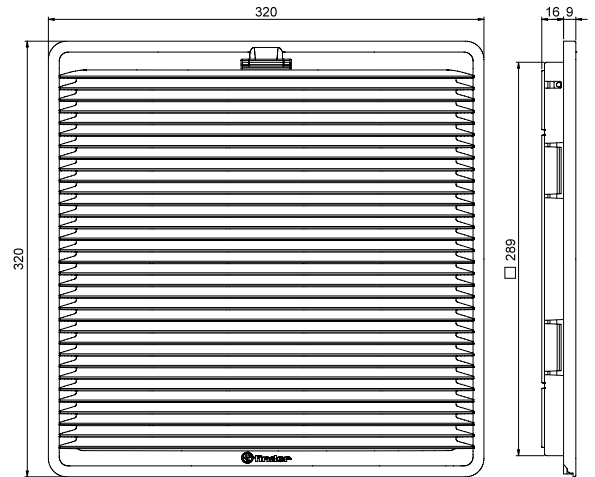

Type 7F.xx.x.xxx.5700  
Push-in terminal

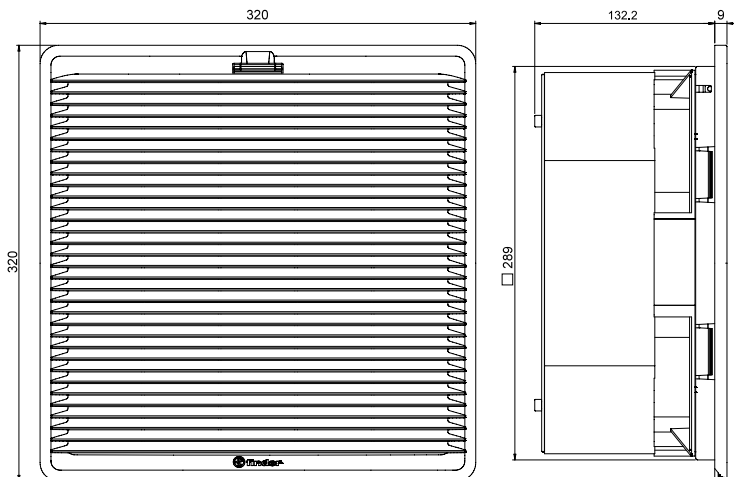

Type 7F.0x.0.000.5000

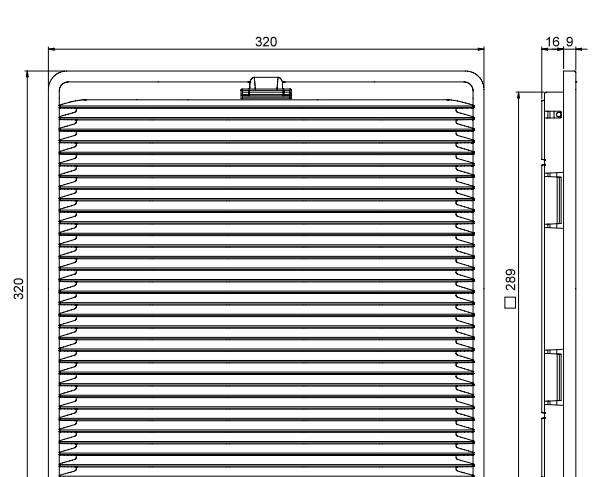

### Fan selection

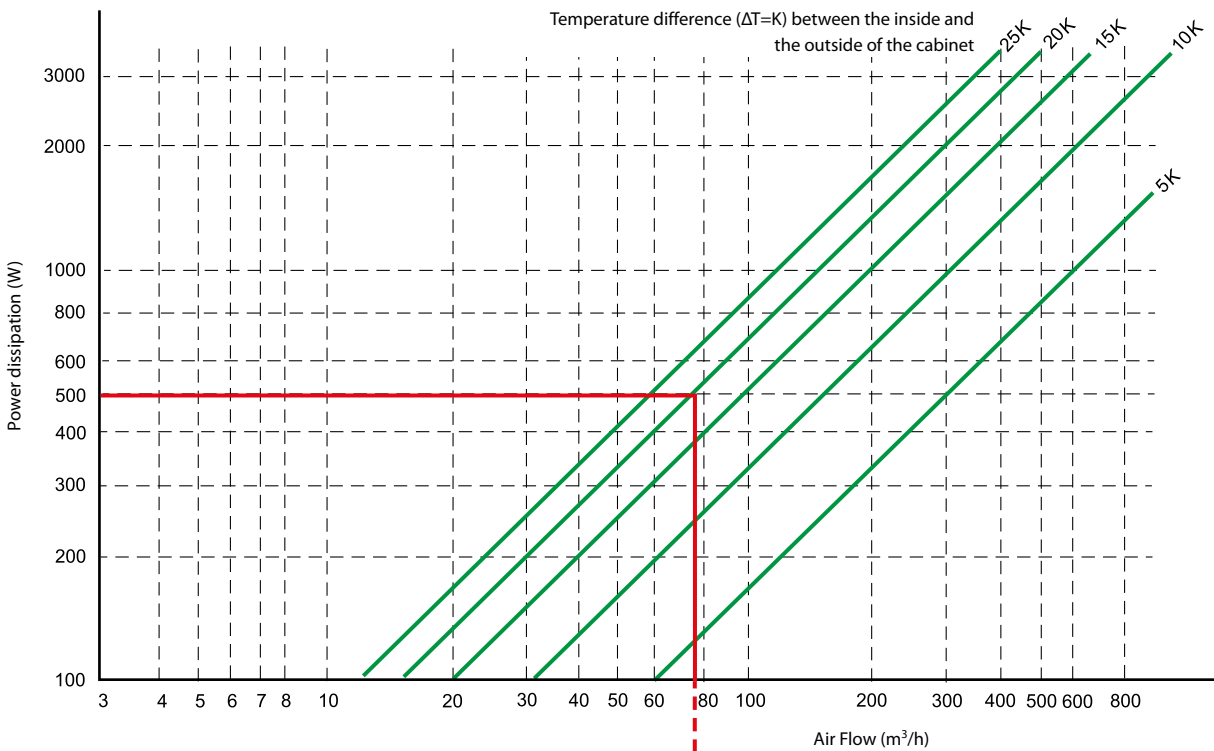

G

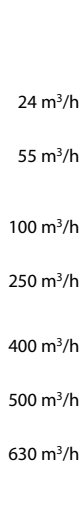

#### Example

First, estimate the power dissipated within the cabinet. Then calculate the maximum difference between the internal and external temperature (green lines) by considering the difference between the maximum permitted internal temperature (as dictated by the temperature rating of the enclosed components, or specification) and the maximum temperature expected outside the cabinet.

The projection onto the X axis, of the intersection between the power (watts) and the appropriate green line, corresponds to the air flow rate in m<sup>3</sup>/h required to meet the maximum internal temperature limit. Extending this line vertically to intersect with the blue horizontal lines, indicates the most appropriate model of 7F fan to be fitted to the cabinet to provide the requisite air flow.

The example above considers a cabinet with an internal thermal power dissipation of 500 W, and assumes the maximum temperature difference between the inside and the outside of the cabinet to be 20K. The required air flow can be seen to be a little less than 80 m<sup>3</sup>/h.

It is suggested that this is increased by 10% to allow for the affects of a dirty filter.

And so, it can be seen that models of the 7F with 100 m<sup>3</sup>/h flow rate will provide the proper dissipation of heat under these circumstances.

## Application notes

### Filter Fan

The ball-bearing axial fan housing is made of aluminium and the rotor is made of plastic or metal (depending on the type).

### Filter classes

Within EN 779 are specified 9 filter classes, categorised into 4 coarse dust filters and 5 fine dust filters.

The coarse dust filters G1 - G4 are able to filter particles > 10 µm and the fine dust filters G5 - G9 are able to filter particles from (1...10)µm.

Filter classes	Example of particle	Particle size
G1 - G4 (EU1 - EU4)	Textile fibers, hair, sand, pollen, spores, insects, cement dust	> 10 µm
G5 - G9 (EU5 - EU9)	Pollen, spores, cement dust, tobacco smoke, oil smoke, soot	(1...10)µm

### Filtering degree (Am)

The degree of filtering (Am) is the percentages of dust, by weight, that is caught and retained by the filter.

### Filter mats

The quality of these filter mats has been independently tested, according to EN 779 and branded after passing the test.

The filter mats are to filter class G3 or G4 and have an average filtering degree of (80...90)%.

### Filter material

The filter material consists of a synthetic fiber with progressive construction which is moisture-resistant to 100% RH and temperature resistant to +100 °C.

According to the strict requirements of fire class F1, DIN 53438, these filter mats are self-extinguishing.

### Progressive construction at filter mats

The individual fibers of these filter mats are bonded by a special process to provide a progressive construction where the fiber size and spacing varies through the thickness of the filter mat.

This means that coarse dust particles are caught early and fine dust later through the thickness of the mat. In this way the entire depth of the filter mat is used.

### Flammability class of the housing and the cover

The plastic materials used comply with flammability class V-0, according to UL94.

### Filter Fan in "reverse flow" version

As supplied, the standard Filter Fan is in "Draw-In"- mode, which means that cool air is filtered and drawn into the cabinet. In some cases it may be required that the warm air is blown out of the cabinet.

In which case it is possible to get Filter Fans in "Exhaust Filter" mode version (7F.21 or 7F.31).

### Mounting of the pressure compensation device

In sealed cabinets and enclosures the internal pressure can vary due to changes in temperature. The pressure compensation device (07F.80) will relieve this internal/external pressure differential whilst maintaining a high level of protection - preventing the ingress of dust and moisture into the cabinet or the enclosure. The pressure compensation device is approved for use in cabinets and enclosures according to DIN EN 62208.

Drill a hole Ø 37<sup>+1.0</sup> mm in the housing wall and fix the pressure compensation device with the accompanying nut. It is important to ensure that the sealing ring is located on the outside. To ensure optimum pressure balance, it is recommended to fit 2 pressure compensation devices at the upper sides of the cabinet or enclosure.



