



Main

Range of Product	Lexium Altivar
Range Compatibility	Lexium 32i Lexium 28 Altivar 32 Lexium 52 Altivar Machine ATV320 Lexium 15 Lexium 05 Lexium 32 Easy Lexium 16
Product compatibility	ATV32HU30N4 ATV32HU40N4 Variable speed drive ATV320 3 kW, 380...500 V, three phase Variable speed drive ATV320 4 kW, 380...500 V, three phase Variable speed drive ATV320 4 kW, 525...600 V, three phase Motion servo drive LXM16D 0.1 kW, 200...230 V, single phase Motion servo drive LXM16D 0.2 kW, 200...230 V, single phase Motion servo drive LXM16D 0.4 kW, 200...230 V, single phase Motion servo drive LXM16D 0.75 kW, 200...230 V, single phase Motion servo drive LXM16D 1 kW, 200...230 V, single phase Motion servo drive LXM16D 1.5 kW, 200...230 V, single phase
Product or Component Type	Braking resistor
Ohmic value	72 Ohm

Complementary

Energy peak	6000 J 480 V 6600 J 400 V 9600 J 230 V 14600 J 115 V
Average power available	50 W 122 °F (50 °C)
Continuous power	200 W
Protection Type	Thermal protection via the servo drive
Net Weight	2.65 lb(US) (1.2 kg)
Cable length	9.84 ft (3 m)

Environment

IP Degree of Protection	IP65
Ambient Air Temperature for Storage	-13...185 °F (-25...85 °C)
Ambient Air Temperature for Operation	32...122 °F (0...50 °C)

Ordering and shipping details

Category	18263-LEXIUM 32 ACCESSORIES
Discount Schedule	PC51
GTIN	3389119207256
Returnability	No
Country of origin	DE

Packing Units

Unit Type of Package 1	PCE
Number of Units in Package 1	1
Package 1 Height	1.77 in (4.5 cm)
Package 1 Width	15.75 in (40.0 cm)
Package 1 Length	5.12 in (13.0 cm)
Package 1 Weight	2.65 lb(US) (1.2 kg)

Offer Sustainability

California proposition 65	WARNING: This product can expose you to chemicals including: Lead and lead compounds, which is known to the State of California to cause cancer and birth defects or other reproductive harm. For more information go to www.P65Warnings.ca.gov
REACH Regulation	REACH Declaration
REACH free of SVHC	Yes
EU RoHS Directive	Pro-active compliance (Product out of EU RoHS legal scope) EU RoHS Declaration
Toxic heavy metal free	Yes
Mercury free	Yes
China RoHS Regulation	China RoHS Declaration
RoHS exemption information	Yes

Contractual warranty

Warranty	18 months
----------	-----------

Braking Resistor

Dimensions

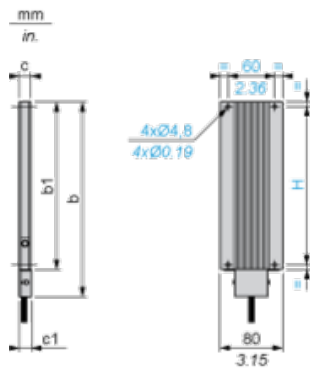

Dimensions in mm

b	b1	c	c1	H
251	216	15	15.5	204

Dimensions in in.

b	b1	c	c1	H
9.88	8.50	0.59	0.61	8.03