

Data sheet | Item number: 216-267

Ferrule; Sleeve for 4 mm² / AWG 12; insulated; electro-tin plated; electrolytic copper; gastight crimped; acc. to DIN 46228, Part 4/09.90; gray

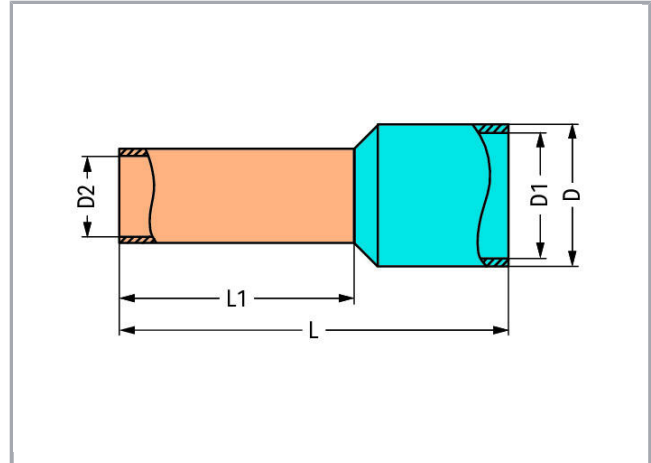

www.wago.com/216-267



Subject to changes. Please also observe the further product documentation!

WAGO Kontakttechnik GmbH & Co. KG
Hansastr. 27
32423 Minden
Phone: +49571 887-0 | Fax: +49571 887-169
Email: info.de@wago.com | Web: www.wago.com

Do you have any questions about our products?
We are always happy to take your call at +49 (571) 887-44222.



Subject to changes. Please also observe the further product documentation!

RoHS 
Compliant

BOMcheck.net

Color: **Data****Technical Data**

Main product function	Ferrule
Sleeve cross-section (AWG)	12 AWG
Sleeve for	4 mm ²

Connection data

Strip length	14 mm / 0.55 inch
--------------	-------------------

Geometrical Data

Length	20 mm
Length	20 mm
Length 1	12 mm
Diameter	5.4 mm
Diameter	5.4 mm
Diameter 1	4.8 mm
Diameter 2	2.8 mm

Material Data

Color	gray
Fire load	0.001 MJ
Weight	0.2 g

Commercial data

Product Group	2 (Terminal Block Accessories)
Packaging type	BOX
Country of origin	DE
GTIN	4044918604338
Customs tariff number	85369010000

Subject to changes. Please also observe the further product documentation!

Counterpart

Downloads

Documentation

Bid Text

216-267 doc - Datei	Sep 11, 2017	doc 24.6 kB	Download
216-267 GAEB X81 - Datei	Feb 19, 2019	xml 2.9 kB	Download

Installation Notes

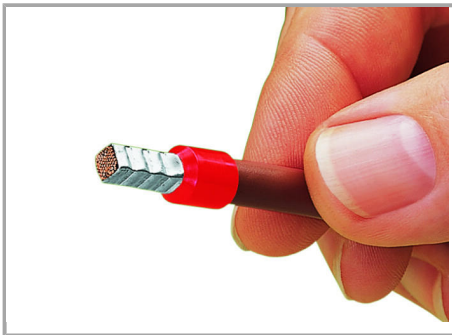

A perfect gas-tight crimp – both electrically and mechanically reliable

Subject to changes. Please also observe the further product documentation!