

ORDERING INFORMATION

Order code: 62937
 Description: BHPS0100/QUADTAP/C/HX/H/K/STD
 UPC: 69549629370

SPECIFICATIONS

Ballast type: Magnetic high pressure sodium
 Ballast style: Core and coil
 Circuit type: HX-HPF
 ANSI code: S54
 Input voltage (V): 120/208/240/277
 Input frequency (Hz): 60
 Line volt regulation: 5 %
 Line watt regulation: Within trapezoid
 Insulation class: H (180)

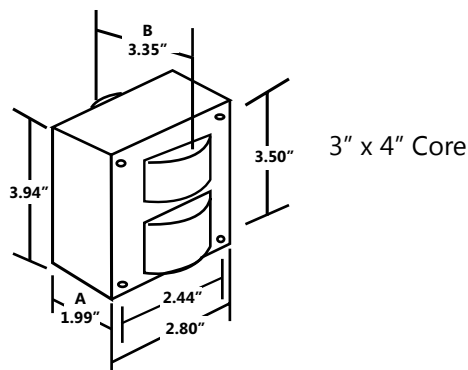

Input voltage (V)	Operating current (A)	Open circuit current (A)	Starting current (A)	Rated lamp watts (W)	Input watts (W)	OCV (V)	Dropout voltage (V)	UL 1029 code	Fuse rating (A)	Input current (A)	Power factor	Starting temperature
120	1.16	2.20	1.00	100	122	120	66	A	8	0.72-1.20	0.90	-40°F / -40°C
208	0.68	1.35	0.66	100	122	120	126	A	5	0.40-0.70	0.90	-40°F / -40°C
240	0.58	1.10	0.50	100	122	120	134	A	5	0.35-0.60	0.90	-40°F / -40°C
277	0.50	0.95	0.42	100	122	120	178	A	3	0.30-0.52	0.90	-40°F / -40°C

HIGH POTENTIAL TEST (V)

1 minute:	2 000
2 seconds:	2 500
OCV test:	127 - 129
Short circuit:	2.80 - 2.81

BALLAST DIMENSIONS

Dimension A:	1.99"
Dimension B:	3.35"
Lead lengths:	12" - 14"
Weight (lbs) :	6.17

WIRING DIAGRAM

Ground ballast core

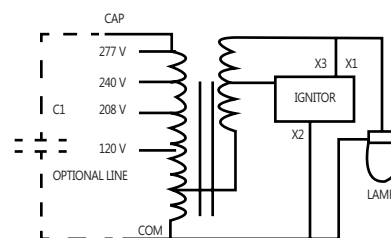

BRACKET

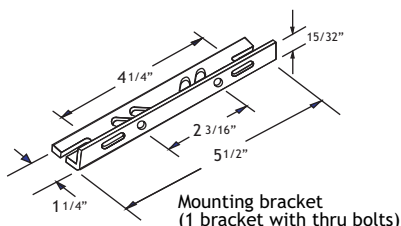

CAPACITOR

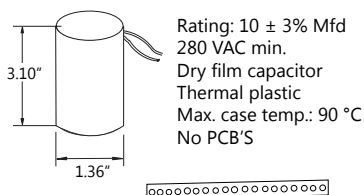

IGNITOR

