

MASS:
CAT. NO.: SPAR-350

TOLERANCES-UNLESS OTHERWISE SPECIFIED
2 PL. DEC. ±.015 TRUE C.L. ±.015
3 PL. DEC. ±.015 ANGLES ±1

DWG. NO.
M2813-06
SHEET 1 OF 1



DRAWN BY: NN SCALE: 1/2
DATE: 4/24/2008 SIZE: A

REV.	DESCRIPTION

Cat #: SPAR-350

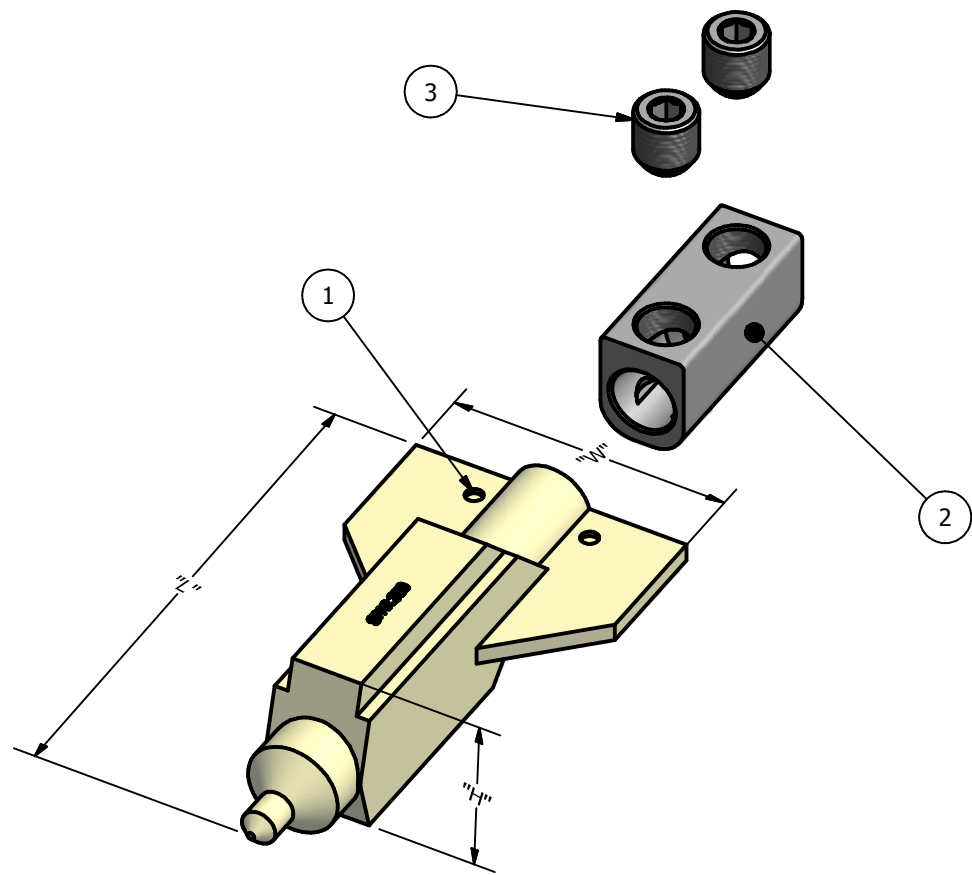

ITEM	"L"	"H"	"W"
1	6.092	1.78	3.245

Parts List			
ITEM	QTY	PART NUMBER	DESCRIPTION
1	1	R1810C01A	COVER WITH HOLES
2	1	D6473C22T	SPA 350 CONNECTOR
3	2	E1093C00T	SCREWS
4	1	R1689C00A	WIRE TIE
5	1	CBR1426	BAG SIZE