



Main

Range of Product	Lexium integrated drive
Product or Component Type	Motion integrated drive
Device short name	ILS
Motor Type	3-phase stepper motor
Number of motor poles	6
Phase	Single phase
[Us] rated supply voltage	24 V 36 V
Network type	DC
Communication interface	I/O for motion sequence, Integrated
Length	7.37 in (187.3 mm)
Winding type	Medium speed of rotation and medium torque
Electrical Connection	Printed circuit board connector
Holding brake	With
Gear box type	Without
Nominal speed	200 rpm 24 V 400 rpm 36 V
Nominal torque	17.70 lbf.in (2 N.m)
Holding torque	53.10 Lbf.in (6 N.m) holding brake 17.70 lbf.in (2 N.m)

Complementary

Transmission Rate	9.6, 19.2 and 38.4 kbauds
Mounting Support	Flange
Motor flange size	3.35 in (85 mm)
Number of motor stacks	1
Centring collar diameter	2.36 in (60 mm)
Centring collar depth	0.08 in (2 mm)
Number of mounting holes	4
Mounting holes diameter	0.26 in (6.5 mm)
Circle diameter of the mounting holes	3.90 in (99 mm)
Feedback type	Index pulse
Shaft end	Untapped
Second shaft	Without second shaft end
Shaft diameter	0.47 in (12 mm)
Shaft length	1.18 in (30 mm)
Supply voltage limits	18...40 V
Current consumption	5000 mA maximum continuous
Associated fuse rating	10 A
Commissioning interface	RS485 9.6, 19.2 and 38.4 kbauds)
Input/output type	4 signals (each be used as input or output)
Voltage state 0 guaranteed	-3...4.5 V
Voltage state 1 guaranteed	15...30 V
Discrete input current	10 MA at 24 V on/STO_A safety input 3 MA at 24 V on/STO_B safety input 10 mA at 24 V 24 V signal interface

Discrete output voltage	10...30 V
Maximum switching current	100 MA per output 200 mA total
Protection Type	Safe torque off Overload of output voltage Short circuit of the output voltage
Peak stall torque	17.70 lbf.in (2 N.m)
Continuous stall torque	17.70 lbf.in (2 N.m)
Speed feedback resolution	20000 points/turn
Accuracy error	+/- 6 arc min
Rotor inertia	1.3 kg.cm ²
Maximum mechanical speed	2000 rpm
Maximum radial force Fr	100 N
Maximum axial force Fa	170 N tensile force) 30 N force pressure)
Service life in hours	20000 h bearing
Brake pull-in power	22 W
Brake release time	40 ms
Brake application time	20 ms
Marking	CE
Type of cooling	Natural convection
Net Weight	9.70 lb(US) (4.4 kg)

Environment

Standards	EN 50347 EN 61800-3 : 2001-02 IEC 60072-1 EN/IEC 50178 EN/IEC 61800-3 IEC 61800-3, Ed 2 EN 61800-3:2001, second environment
Product Certifications	TÜV[RETURN]cUL[RETURN]UL
Ambient air temperature for operation	122...149 °F (50...65 °C) with power derating of 2 % per °C) 32...122 °F (0...50 °C) without derating)
Permissible ambient air temperature around the device	230 °F (110 °C) motor
Ambient Air Temperature for Storage	-13...158 °F (-25...70 °C)
Operating altitude	<= 3280.84 ft (1000 m) without derating
Relative humidity	15...85 % without condensation
Vibration resistance	20 m/s ² 10...500 Hz) 10 cycles EN/IEC 60068-2-6
Shock resistance	150 m/s ² 1000 shocks EN/IEC 60068-2-29
IP degree of protection	Shaft bushing IP41 EN/IEC 60034-5 Total except shaft bushing IP54 EN/IEC 60034-5

Ordering and shipping details

Category	18288-LEXIUM INTEGRATED DRIVES II
Discount Schedule	PC56
GTIN	3389119227308
Returnability	No
Country of origin	DE

Packing Units

Unit Type of Package 1	PCE
Number of Units in Package 1	1
Package 1 Height	4.13 in (10.5 cm)
Package 1 Width	7.48 in (19.0 cm)
Package 1 Length	15.35 in (39.0 cm)
Package 1 Weight	7.50 lb(US) (3.4 kg)

Offer Sustainability

Sustainable offer status	Green Premium product
California proposition 65	WARNING: This product can expose you to chemicals including: Lead and lead compounds, which is known to the State of California to cause cancer and birth defects or other reproductive harm. For more information go to www.P65Warnings.ca.gov
REACH Regulation	REACH Declaration
EU RoHS Directive	Pro-active compliance (Product out of EU RoHS legal scope)
Mercury free	Yes
China RoHS Regulation	China RoHS Declaration
RoHS exemption information	Yes
Environmental Disclosure	Product Environmental Profile
Circularity Profile	End Of Life Information
WEEE	The product must be disposed on European Union markets following specific waste collection and never end up in rubbish bins.
PVC free	Yes

Contractual warranty

Warranty	18 months
----------	-----------

Integrated Drive with Holding Brake

Dimensions

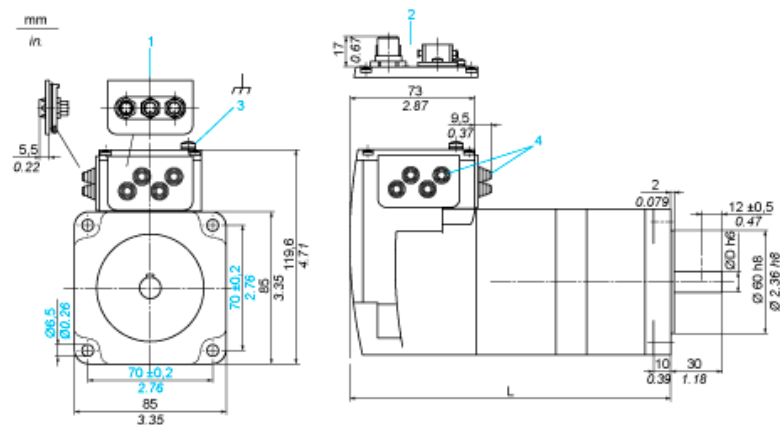

- 1 Accessories: I/O signal insert with industrial connectors
 - 2 Option: industrial connectors
 - 3 Earth (ground) terminal
 - 4 Accessories: cable entries $\varnothing = 3 \dots 9 \text{ mm} / 0.12 \dots 0.35 \text{ in.}$
- L 187.3 mm/7.37 in.
D 12 mm/0.47 in.

Connection Example with 4 I/O Signals

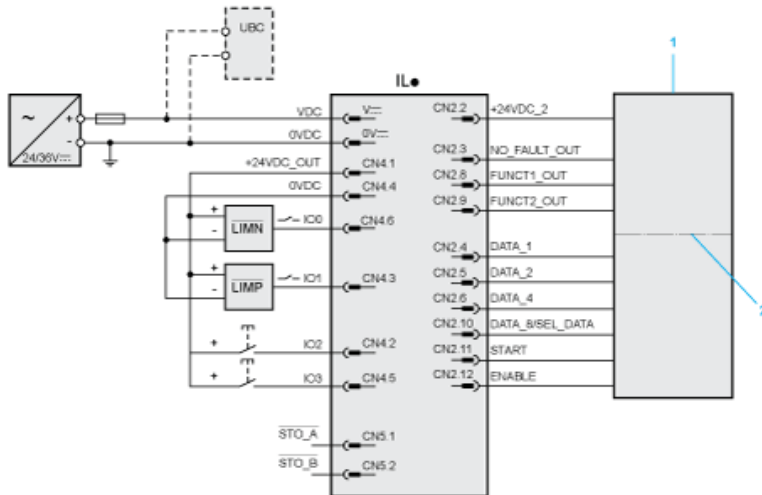

- 1 PLC
- 2 Galvanic isolation

Torque Characteristics

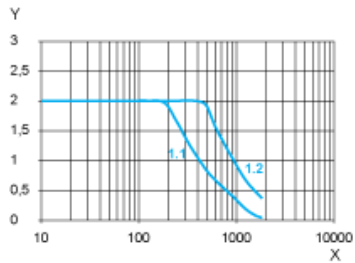

X Speed of rotation in rpm

Y Torque in Nm

1.1 Max. torque at 24 V

1.2 Max. torque at 36 V