

# ZB5RTA1

Wireless and batteryless transmitter, Harmony XB5R, push button, plastic, white, 22mm, spring return



## Main

Range of Product	Harmony XB5
Product or Component Type	Wireless and batteryless transmitter
Device short name	XB5R
Bezel material	Dark grey plastic
Fixing collar material	Plastic
Mounting diameter	0.87 in (22 mm)
Transmission frequency	2405 MHz
Emission class	5M00G7W
Antenna type	Omnidirectional

## Complementary

Shape of signaling unit head	Round
Type of operator	Spring return push-button with transmitter
Operator profile	White flush
Max power consumption in W	1 mW
Number of Channels	16
Modulation technique	O-QPSK
Bandwidth	5 MHz
Antenna gain	0 dBi
Embedding Depth	1.65 in (42 mm)
CAD overall height	1.63 in (41.5 mm)
CAD overall width	1.18 in (30 mm)
CAD overall depth	1.69 in (43 mm)
Net Weight	0.10 lb(US) (0.045 kg)
Operating travel	0.17 in (4.3 mm) total travel)
Operating force	10 N C/O changing electrical state
Mechanical robustness	Free fall resistance 1000 mm EN/IEC 60068-2-32
Standards	CSA C22.2 No 14 EN/IEC 60947-1 EN/IEC 60947-5-1 UL 508
Radio agreement	ANATEL ARIB T66 FCC ICASA RSS
Communication port protocol	Zigbee green power 2.4 GHz IEEE 802.15.4
Maximum sensing distance	328.08 Ft (100 m) in free field 82.02 Ft (25 m) transmitter in a plastic box type XAL D and receiver in a metal enclosure 984.25 ft (300 m) transmitter in box type XAL D, receiver in metal enclosure and use relay-antenna
Acquisition time	2 ms
Response time	< 2 ms
Emission Power	3 mW
Fixing mode	Fixing nut beneath head 17.70...21.24 lbf.in (2...2.4 N.m)

The information provided in this documentation contains general descriptions and/or technical characteristics of the performance of the products contained herein. This documentation is not intended as a substitute for and is not to be used for determining suitability or reliability of these products for specific user applications. It is the duty of any such user or integrator to perform the appropriate and complete risk analysis, evaluation and testing of the products with respect to the relevant specific application or use thereof. Neither Schneider Electric Industries SAS nor any of its affiliates or subsidiaries shall be responsible or liable for misuse of the information contained herein.

Station name	XALD 1...5 cut-outs XALK 2...5 cut-outs
Electrical composition code	PW1

## Environment

Ambient Air Temperature for Storage	-40...158 °F (-40...70 °C)
Ambient Air Temperature for Operation	-40...158 °F (-40...70 °C)
Relative humidity	95 % -40...158 °F (-40...70 °C) without condensation
IP degree of protection	IP66 IEC 60529 front face) IP67 IEC 60529 front face) IP69 IEC 60529 front face) IP69K IEC 60529 front face)
IK degree of protection	IK03 IEC 50102
Mechanical durability	1000000 cycles
Shock resistance	25 gn 6 ms) 6000 shocks IEC 60068-2-27 30 gn 18 ms) half sine wave acceleration IEC 60068-2-27 50 gn 11 ms) half sine wave acceleration IEC 60068-2-27
Vibration resistance	5 gn 11...500 Hz)IEC 60068-2-6 +/- 10 mm 2...11 Hz)IEC 60068-2-6
Electromagnetic compatibility	Electrostatic discharge immunity test - test level: 8 kV (in free air (in insulating parts)) conforming to IEC 61000-4-2 Electrostatic discharge immunity test - test level: 4 kV (on contact (on metal parts)) conforming to IEC 61000-4-2 Susceptibility to electromagnetic fields - test level: 20 V/m (80...3000 MHz) conforming to IEC 61000-4-3 Susceptibility to electromagnetic fields - test level: 6 V/m (3000...6000 MHz, distance = 20 m) conforming to IEC 61000-4-3
Product Certifications	CSA[RETURN]C-tick[RETURN]GOST[RETURN]BT 2006/95/EC[RETURN]UL
Directives	1999/5/EC - R&TTE directive 2004/108/EC - electromagnetic compatibility

## Ordering and shipping details

Category	22470-XB5R WIRELESS PUSH BUTTON
Discount Schedule	I
GTIN	3606480334573
Returnability	Yes
Country of origin	FR

## Packing Units

Unit Type of Package 1	PCE
Number of Units in Package 1	1
Package 1 Height	1.26 in (3.2 cm)
Package 1 Width	2.13 in (5.4 cm)
Package 1 Length	3.31 in (8.4 cm)
Package 1 Weight	1.83 oz (52.0 g)
Unit Type of Package 2	S01
Number of Units in Package 2	25
Package 2 Height	5.91 in (15.0 cm)
Package 2 Width	5.91 in (15.0 cm)
Package 2 Length	15.75 in (40.0 cm)
Package 2 Weight	3.31 lb(US) (1.502 kg)

## Offer Sustainability

Sustainable offer status	Green Premium product
California proposition 65	WARNING: This product can expose you to chemicals including: Lead and lead compounds, which is known to the State of California to cause cancer and birth defects or other reproductive harm. For more information go to <a href="http://www.P65Warnings.ca.gov">www.P65Warnings.ca.gov</a>
REACH Regulation	<a href="#">REACH Declaration</a>
EU RoHS Directive	Pro-active compliance (Product out of EU RoHS legal scope)
Mercury free	Yes
China RoHS Regulation	<a href="#">China RoHS Declaration</a>
RoHS exemption information	<a href="#">Yes</a>
Environmental Disclosure	<a href="#">Product Environmental Profile</a>
Circularity Profile	<a href="#">End Of Life Information</a>
WEEE	The product must be disposed on European Union markets following specific waste collection and never end up in rubbish bins.

## Contractual warranty

Warranty	18 months
----------	-----------

---

Wireless and Batteryless Pushbutton - Transmitter

---

With Plastic Pushbutton without Cap

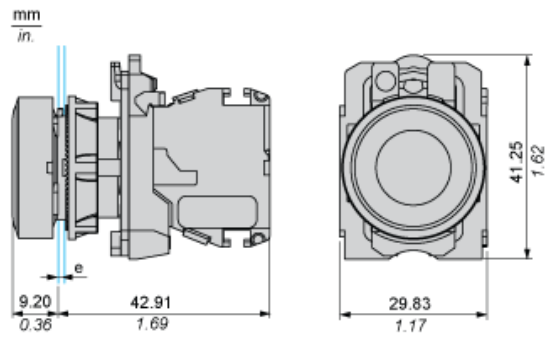

e: panel thickness 1 to 6 mm / 0.039 to 0.24 in.

Transmitter Mounting

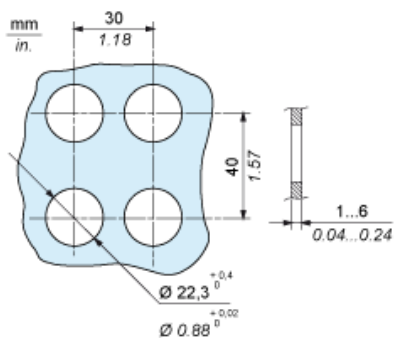

Transmitter Clearance in Free Field Unobstructed

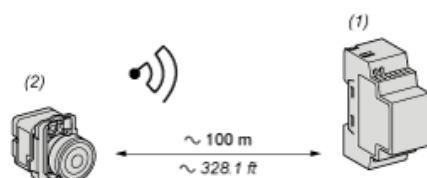

- (1): Receiver
- (2): Transmitter

Transmitter Clearance in a Metal Enclosure

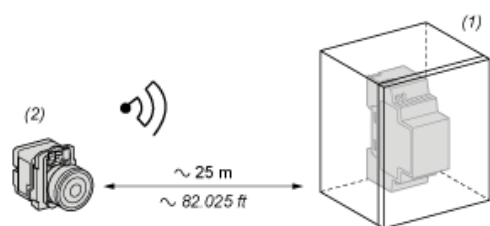

- (1): Metal enclosure
- (2): Transmitter

The range is reduced if the transmitter is placed in a metal enclosure (reduction factor: approx 10%)

Glass window	10...20 %
Plaster wall	30...45 %
Brick wall	60 %
Concrete wall	70...80 %
Metal structure	50...100 %