

# BCH2MM0613CA6C

servo motor BCH, Lexium 28, 130mm, 600W, 6.63kg.cm<sup>2</sup>, with oil seal, with key, straight connection



## Main

Range Compatibility	Lexium 28
Product or Component Type	Servo motor
Device short name	BCH2

## Complementary

Maximum mechanical speed	3000 rpm
[Us] rated supply voltage	220 V 110 V
Phase	Three phase Single phase
Continuous stall current	3.77 A
Continuous stall torque	50.71 Lbf.in (5.73 N.m) LXM26D 4.5 A, 220 V, single phase 50.71 Lbf.in (5.73 N.m) LXM26D 4.5 A, 220 V, three phase 50.71 Lbf.in (5.73 N.m) LXM28... 4.5 A, 220 V, single phase 50.71 Lbf.in (5.73 N.m) LXM28... 4.5 A, 220 V, three phase 50.71 lbf.in (5.73 N.m) LXM28... 9 A, 110 V, single phase
Continuous power	600 W
Peak stall torque	152.14 Lbf.in (17.19 N.m) LXM26D 4.5 A, 220 V, single phase 152.14 Lbf.in (17.19 N.m) LXM26D 4.5 A, 220 V, three phase 152.14 Lbf.in (17.19 N.m) LXM28... 4.5 A, 220 V, single phase 152.14 Lbf.in (17.19 N.m) LXM28... 4.5 A, 220 V, three phase 152.14 lbf.in (17.19 N.m) LXM28... 9 A, 110 V, single phase
Nominal output power	600 W LXM26D 4.5 A, 220 V, single phase 600 W LXM26D 4.5 A, 220 V, three phase 600 W LXM28... 4.5 A, 220 V, single phase 600 W LXM28... 4.5 A, 220 V, three phase 600 W LXM28... 9 A, 110 V, single phase
Nominal torque	50.71 Lbf.in (5.73 N.m) LXM26D 4.5 A, 220 V, single phase 50.71 Lbf.in (5.73 N.m) LXM26D 4.5 A, 220 V, three phase 50.71 Lbf.in (5.73 N.m) LXM28... 4.5 A, 220 V, single phase 50.71 Lbf.in (5.73 N.m) LXM28... 4.5 A, 220 V, three phase 50.71 lbf.in (5.73 N.m) LXM28... 9 A, 110 V, single phase
Nominal speed	1000 rpm LXM26D 4.5 A, 220 V, single phase 1000 rpm LXM26D 4.5 A, 220 V, three phase 1000 rpm LXM28... 4.5 A, 220 V, single phase 1000 rpm LXM28... 4.5 A, 220 V, three phase 1000 rpm LXM28... 9 A, 110 V, single phase
Maximum current Irms	13.44 A LXM28... 0.6 kW, 220 V 13.44 A LXM28... 0.6 kW, 110 V
Maximum permanent current	4.1 A
Product compatibility	LXM26D servo drive 0.6 kW, 220 V, single phase LXM26D servo drive 0.6 kW, 220 V, three phase LXM28... servo drive 0.6 kW, 220 V, single phase LXM28... servo drive 0.6 kW, 220 V, three phase LXM28... servo drive 0.6 kW, 110 V, single phase
Shaft end	Keyed

Shaft diameter	0.87 in (22 mm)
Shaft length	1.77 in (45 mm)
Key width	0.31 in (8 mm)
Feedback type	20 bits single turn absolute encoder
Holding brake	Without
Mounting Support	Asian standard flange
Motor flange size	5.12 in (130 mm)
Electrical connection	Connector MIL
Torque constant	1.52 N.m/A 68 °F (20 °C)
Back emf constant	92 V/krpm 68 °F (20 °C)
Rotor inertia	6.63 kg.cm <sup>2</sup>
Stator resistance	1.93 Ohm 68 °F (20 °C)
Stator inductance	24.9 mH 68 °F (20 °C)
Stator electrical time constant	12.9 ms 68 °F (20 °C)
Maximum radial force Fr	670 N 1000 rpm
Maximum axial force Fa	200 N
Brake pull-in power	19.7 W
Type of cooling	Natural convection
Length	5.79 in (147 mm)
Number of motor stacks	1
Centring collar diameter	4.33 in (110 mm)
Centring collar depth	0.31 in (8 mm)
Number of mounting holes	4
Mounting holes diameter	0.36 in (9.2 mm)
Circle diameter of the mounting holes	5.71 in (145 mm)
Distance shaft shoulder-flange	0.31 in (8 mm)
Net Weight	15.43 lb(US) (7 kg)

## Environment

IP Degree of Protection	IP50 IM V3 IP65 IM B5, IM V1
Ambient Air Temperature for Operation	-4...104 °F (-20...40 °C)

## Ordering and shipping details

Category	18281-LEXIUM 23/28 MOTORS
Discount Schedule	PC53
GTIN	00785901829256
Returnability	No
Country of origin	CN

## Packing Units

Unit Type of Package 1	PCE
Number of Units in Package 1	1
Package 1 Height	7.13 in (18.1 cm)
Package 1 Width	9.06 in (23 cm)
Package 1 Length	14.17 in (36 cm)
Package 1 Weight	284.66 oz (8070 g)

## Offer Sustainability

Sustainable offer status	Green Premium product
California proposition 65	WARNING: This product can expose you to chemicals including: Lead and lead compounds, which is known to the State of California to cause cancer and birth defects or other reproductive harm. For more information go to <a href="http://www.P65Warnings.ca.gov">www.P65Warnings.ca.gov</a>
REACH Regulation	<a href="#">REACH Declaration</a>
REACH free of SVHC	Yes
EU RoHS Directive	Pro-active compliance (Product out of EU RoHS legal scope)
Mercury free	Yes
China RoHS Regulation	<a href="#">China RoHS Declaration</a>
RoHS exemption information	<a href="#">Yes</a>
Environmental Disclosure	<a href="#">Product Environmental Profile</a>
Circularity Profile	<a href="#">End Of Life Information</a>
WEEE	The product must be disposed on European Union markets following specific waste collection and never end up in rubbish bins.
PVC free	Yes

Dimensions

Dimensions of Motor

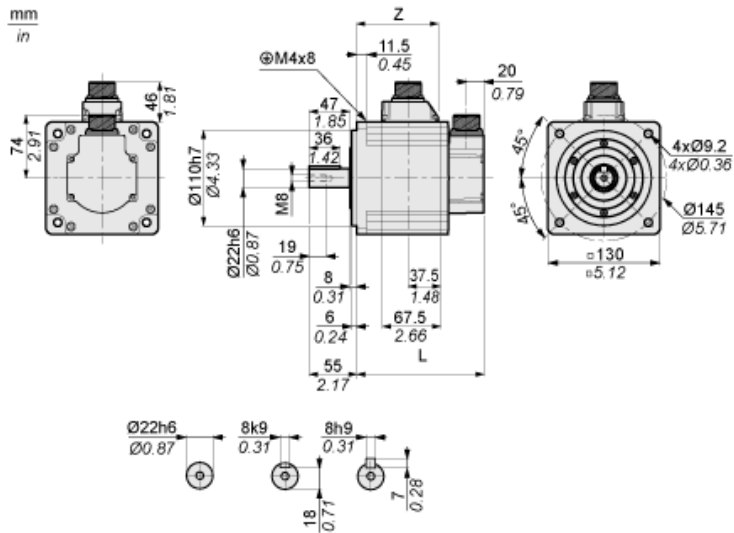

	mm	in.
L (without holding brake)	147	5.79
L (with holding brake)	183	7.2
Z	94.5	3.72

Torque/Speed Curves with 230 V Single/Three Phase Supply Voltage

Servo Motor with LXM28AU02●●● Servo Drive

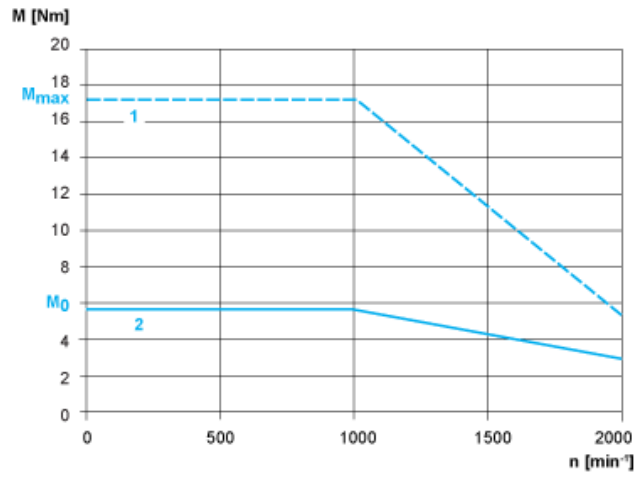

- 1 : Peak torque
- 2 : Continuous torque