



## Main

Product name	PowerPacT H
Product or Component Type	Enclosure
Circuit breaker type	HDL HGL

## Complementary

Number of poles	2
Line Rated Current	15...100 A 125...150 A
Type of Installation	Indoor

## Environment

Product Certifications	NEMA 1
------------------------	--------

## Ordering and shipping details

Category	00030-IND CB ENCL NEMA 1,3R
Discount Schedule	DE1
GTIN	785901984832
Returnability	Yes
Country of origin	MX

## Packing Units

Unit Type of Package 1	PCE
Number of Units in Package 1	1
Package 1 Height	6.50 in (16.5 cm)
Package 1 Width	15.39 in (39.1 cm)
Package 1 Length	33.19 in (84.3 cm)
Package 1 Weight	36.46 lb(US) (16.54 kg)
Unit Type of Package 2	PAL
Number of Units in Package 2	16
Package 2 Height	40.00 in (101.6 cm)
Package 2 Width	42.00 in (106.68 cm)
Package 2 Length	48.00 in (121.92 cm)
Package 2 Weight	615.55 lb(US) (279.21 kg)

The information provided in this documentation contains general descriptions and/or technical characteristics of the performance of the products contained herein. This documentation is not intended as a substitute for and is not to be used for determining suitability or reliability of these products for specific user applications. It is the duty of any such user or integrator to perform the appropriate and complete risk analysis, evaluation and testing of the products with respect to the relevant specific application or use thereof. Neither Schneider Electric Industries SAS nor any of its affiliates or subsidiaries shall be responsible or liable for misuse of the information contained herein.

## Offer Sustainability

Sustainable offer status	Green Premium product
California proposition 65	WARNING: This product can expose you to chemicals including: Lead and lead compounds, which is known to the State of California to cause cancer and birth defects or other reproductive harm. For more information go to <a href="http://www.P65Warnings.ca.gov">www.P65Warnings.ca.gov</a>
REACH Regulation	<a href="#">REACH Declaration</a>
EU RoHS Directive	Compliant <a href="#">EU RoHS Declaration</a>
Toxic heavy metal free	Yes
Mercury free	Yes
China RoHS Regulation	<a href="#">China RoHS Declaration</a>
RoHS exemption information	<a href="#">Yes</a>
Environmental Disclosure	<a href="#">Product Environmental Profile</a>
Circularity Profile	No need of specific recycling operations
PVC free	Yes
Halogen content performance	Halogen free plastic parts product

Approximate Dimensions: Refer to Drawing 3362S

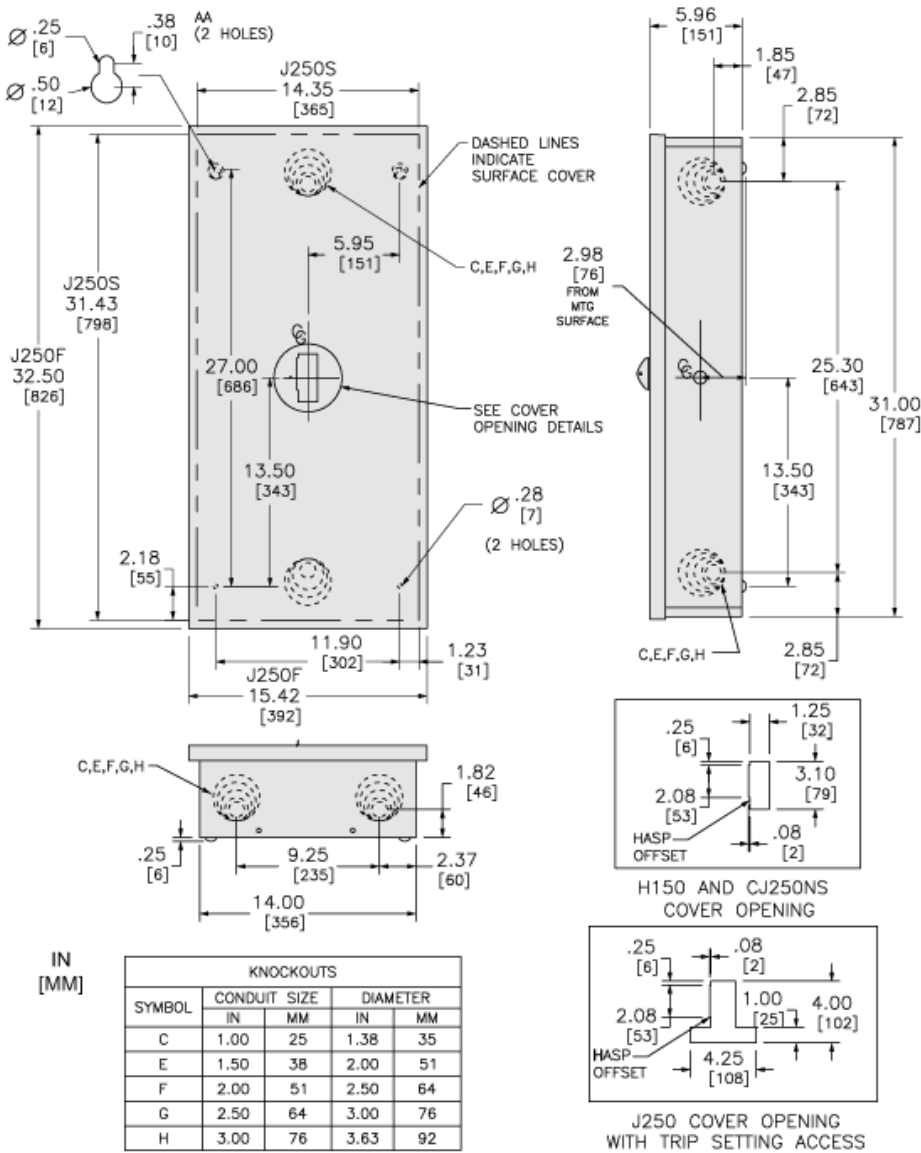

IN  
[MM]

SYMBOL	KNOCKOUTS			
	CONDUIT SIZE		DIAMETER	
	IN	MM	IN	MM
C	1.00	25	1.38	35
E	1.50	38	2.00	51
F	2.00	51	2.50	64
G	2.50	64	3.00	76
H	3.00	76	3.63	92