

TM2DDI16DK

Discrete input module, Modicon M238 logic controller, 16 inputs 24 V DC, 1 connector HE10



Main

Range of Product	Modicon M238 logic controller
Product or Component Type	Discrete input module
Discrete input number	16
Discrete input voltage	24 V
Discrete input voltage type	DC

Complementary

Range Compatibility	Advantys OTB Twido
Input voltage limits	20.4...28.8 V
Discrete input logic	Sink or source
Discrete input current	5 mA
Input impedance	4.4 kOhm
Number of common point	1
Response time	4 ms at state 0 4 ms at state 1
Isolation between channels	None
Isolation between channels and internal logic	500 V for 1 minute
Current consumption	35 mA 5 V DC at state 1 for all input
Local signalling	2 display blocks
Electrical connection	1 connector HE10
Mounting Support	35 mm symmetrical DIN rail
Net Weight	0.22 lb(US) (0.1 kg)

Environment

Depth	3.20 in (81.3 mm)
Height	3.54 in (90 mm)
Width	0.84 in (21.4 mm)

Ordering and shipping details

Category	22531-PLCS, TWIDO, TWD
Discount Schedule	PC12
GTIN	3595863995732
Returnability	No
Country of origin	JP

The information provided in this documentation contains general descriptions and/or technical characteristics of the performance of the products contained herein. This documentation is not intended as a substitute for and is not to be used for determining suitability or reliability of these products for specific user applications. It is the duty of any such user or integrator to perform the appropriate and complete risk analysis, evaluation and testing of the products with respect to the relevant specific application or use thereof. Neither Schneider Electric Industries SAS nor any of its affiliates or subsidiaries shall be responsible or liable for misuse of the information contained herein.

Packing Units

Unit Type of Package 1	PCE
Number of Units in Package 1	1
Package 1 Height	2.95 in (7.5 cm)
Package 1 Width	4.13 in (10.5 cm)
Package 1 Length	5.12 in (13.0 cm)
Package 1 Weight	5.93 oz (168.0 g)
Unit Type of Package 2	S01
Number of Units in Package 2	6
Package 2 Height	5.91 in (15.0 cm)
Package 2 Width	5.91 in (15.0 cm)
Package 2 Length	15.75 in (40.0 cm)
Package 2 Weight	2.54 lb(US) (1.153 kg)

Offer Sustainability

California proposition 65	WARNING: This product can expose you to chemicals including: Lead and lead compounds, which is known to the State of California to cause cancer and birth defects or other reproductive harm. For more information go to www.P65Warnings.ca.gov
REACH Regulation	 REACH Declaration
REACH free of SVHC	Yes
EU RoHS Directive	Pro-active compliance (Product out of EU RoHS legal scope)
Mercury free	Yes
China RoHS Regulation	 China RoHS Declaration
RoHS exemption information	 Yes
WEEE	The product must be disposed on European Union markets following specific waste collection and never end up in rubbish bins.
PVC free	Yes

Contractual warranty

Warranty	18 months
----------	-----------

Digital Input Module (16-channel, 24 Vdc)

Dimensions

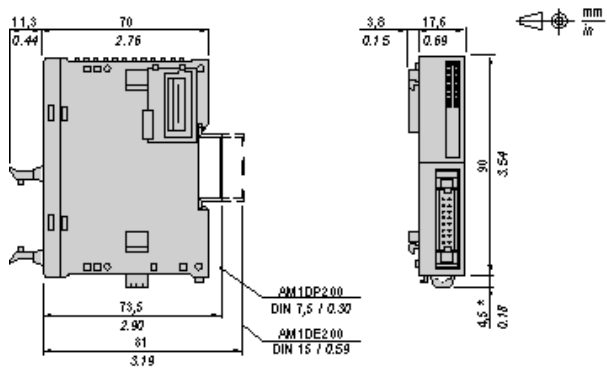

NOTE: * 8.5 mm (0.33 in) when the clamp is pulled out.

DIN Rail Mounting

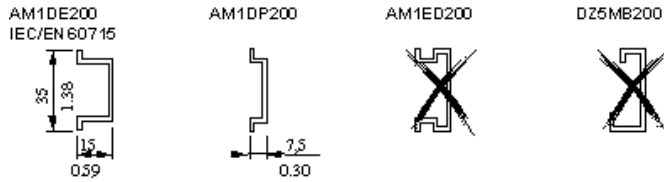

Rail depth	Catalogue part number
15 mm (0.59 in.)	AM1DE200
7,5 mm (0.30 in.)	AM1DP200

NOTE: Do not use AM1ED200 and DZ5MB200

Module Mounting on a Panel Surface

Mounting Hole Layout

