



## Main

Range of product	OsiSense XM
Product or component type	Electronic pressure sensors
Pressure sensor type	Pressure transmitter
Pressure sensor name	XMLP
Electrical circuit type	Control circuit
Pressure sensor size	-14.5...60 psi (-99.97...413.69 kPa)
Local display	Without
Controlled fluid	Fresh water 32...257 °F (0...125 °C) Air 5...257 °F (-15...125 °C) Gas 5...257 °F (-15...125 °C) Hydraulic oil 5...257 °F (-15...125 °C)
Fluid connection type	1/4" - 18 NPT (male)
Electrical connection	1 male connector EN 175301-803-A (ex DIN43650) 3 pins
[Us] rated supply voltage	12...24 V DC SELV 7...33 V)
Current consumption	< 23 mA
Type of output signal	Analogue
Analogue output function	4...20 mA, 2-wire
Quantity per set	Set of 1
Type of packing	Individual

## Complementary

Pressure setting range	-14.5...60 psi (-99.97...413.69 kPa)
Maximum permissible accidental pressure	260 psi (1792.64 kPa)
Destruction pressure	350 psi (2413.16 kPa)
Materials in contact with fluid	Stainless steel AISI 316L Fluorocarbon FPM Ceramic

Operating position	Any position
Protection type	Reverse polarity Load short-circuit
Electromagnetic compatibility	Susceptibility to electromagnetic fields EN/IEC 61000-4-3 10 V/m 80...1000 MHz Radiated RF fields EN/IEC 61000-4-6 10 V 0.15...80 MHz Electrostatic discharge immunity test EN/IEC 61000-4-2 8 kV air, 4 kV contact 1.2/50 $\mu$ s shock waves immunity test EN/IEC 61000-4-5 1 kV 42 Ohm Immunity to magnetic fields EN/IEC 61000-4-8 100 A/m 50 Hz Electrical fast transient/burst immunity test EN/IEC 61000-4-4 4 kV
[Uimp] rated impulse withstand voltage	0.5 kV
Response time on output	$\leq$ 2 ms 10...90 % of full scale
Measurement accuracy	+/- 0.5 % of the measuring range
Resolution	0.1 % of the measuring range
Drift of the sensitivity	+/- 0.02 % of measuring range/ $^{\circ}$ K
Drift of the zero point	+/- 0.02 % of measuring range/ $^{\circ}$ K
Long term stability	+/- 0.25 % of the measuring range
Mechanical durability	10000000 cycles
Net weight	0.21 lb(US) (0.095 kg)
Diameter	1.02 in (26 mm)
Length	2.09 in (53 mm)

## Environment

Standards	EN/IEC 61326-2-3 NSF ANSI 61
Product certifications	CULus RCM EAC CE
Ambient air temperature for operation	-22...185 $^{\circ}$ F (-30...85 $^{\circ}$ C)
Ambient air temperature for storage	-58...212 $^{\circ}$ F (-50...100 $^{\circ}$ C)
Vibration resistance	20 gn 10...2000 Hz) EN/IEC 60068-2-6
Shock resistance	100 gn 11 ms EN/IEC 60068-2-27
IP degree of protection	IP65 conforming to EN/IEC 60529

## Packing Units

Unit Type of Package 1	PCE
Number of Units in Package 1	1
Package 1 Weight	3.35 oz (95 g)
Package 1 Height	1.61 in (4.1 cm)
Package 1 width	1.77 in (4.5 cm)
Package 1 Length	3.35 in (8.5 cm)

## Offer Sustainability

Sustainable offer status	Green Premium product
REACH Regulation	<a href="#">REACH Declaration</a>
REACH free of SVHC	Yes
EU RoHS Directive	Pro-active compliance (Product out of EU RoHS legal scope) <a href="#">EU RoHS Declaration</a>
Mercury free	Yes
RoHS exemption information	<a href="#">Yes</a>
Environmental Disclosure	<a href="#">Product Environmental Profile</a>

Dimensions

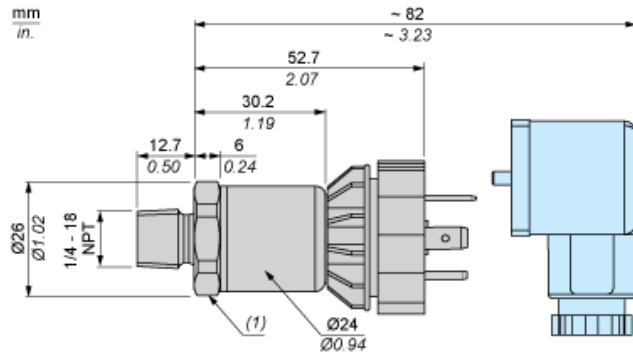

(1) SW24 tightening torque ≤ 25 N.m / 221 lb-in

---

Connection and Schema

---

Wiring Diagram

2-Wire Technique (4-20 mA)



(a) I out

---

Performance Curves

---

Curves

