



ANSI/ASSP
Z359.11-2021

OSHA 29 CFR 1910.140
OSHA 29 CFR 1926.502

EXOFIT™ SERIES X300 FULL BODY HARNESS



USER INSTRUCTIONS 5908049 REV. D

Fall Protection

For identification of product codes, refer to Table 1. See "Table 1 - Product Specifications" for more product information.

Figure 1 - Product Overview

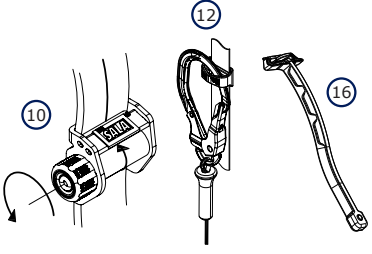
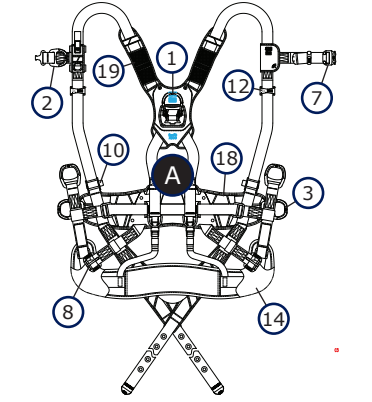
|  |  | Harness Style A | Harness Model | ① | ② | ③ | ④ | ⑤ | ⑥ | ⑦ | ⑧ | ⑨ | ⑩ | ⑪ | ⑫ | ⑬ | ⑭ | ⑮ | ⑯ | ⑰ | ⑱ | ⑳ | | |
|----------------------------------------------------------------------------------|------------------------------------------------------------------------------------|--------------------------------------|----------------------|---------------------|---------|---------|----------|-----------------------|------------------|---------------|----------|----------------|----------|---------------|----------------|-------------|------------|-----------|------|------|---------|-------------------|---------|--|
| | | | | Dorsal | Sternal | Hip | Shoulder | Rear Waist | D-ring Extension | Quick Connect | Tongue | Pass-Through | Revolver | Trauma Straps | Lanyard Keeper | SRD Adapter | Seat Sling | Gear Loop | WDS | Belt | Hip Pad | Back and Shoulder | Leg Pad | |
| | | | | Attachment Elements | | | | Buckles and Adjusters | | | | Other Elements | | | | | | | Pads | | | | | |
| 1113000 | 1113001 | 1113004 | 1113007 | 1113010 | 1113013 | 1113014 | 1113001H | 1113004H | 1113007H | 1113010H | 1113013H | 1113014H | | | | | | | | | | | | |
| ✓ | | | | | | | | | | | | | | | | | | | | | | | | |
| | | | | | | | | | | | | | | | | | | | | | | | | |
| 1113030 | 1113031 | 1113034 | 1113037 | 1113040 | 1113043 | | | | | | | | | | | | | | | | | | | |
| ✓ | ✓ | | | | | | | | | | | | | | | | | | | | | | | |
| | | | | | | | | | | | | | | | | | | | | | | | | |
| 1113045 | 1113046 | 1113049 | 1113052 | 1113055 | 1113058 | | | | | | | | | | | | | | | | | | | |
| ✓ | | ✓ | | | | | | | | | | | | | | | | | | | | | | |
| | | | | | | | | | | | | | | | | | | | | | | | | |
| 1113061 | 1113064 | 1113067 | 1113070 | 1113073 | | | | | | | | | | | | | | | | | | | | |
| ✓ | | | ✓ | | | | | | | | | | | | | | | | | | | | | |
| | | | | | | | | | | | | | | | | | | | | | | | | |
| 1113075 | 1113076 | 1113079 | 1113082 | 1113083 | 1113085 | 1113088 | | | | | | | | | | | | | | | | | | |
| ✓ | ✓ | ✓ | | | | | | | | | | | | | | | | | | | | | | |
| | | | | | | | | | | | | | | | | | | | | | | | | |

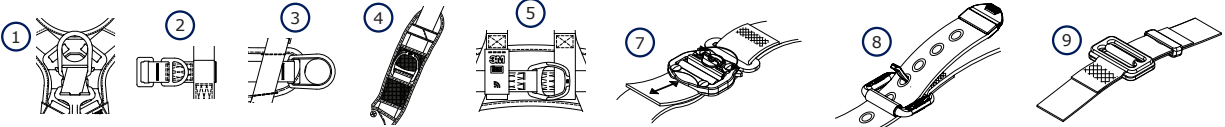
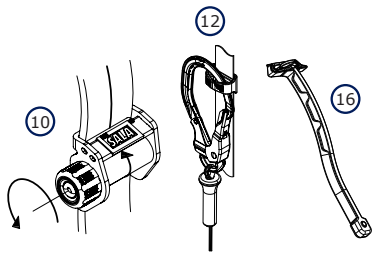
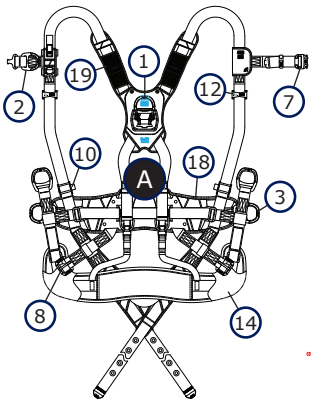

Figure 1 - Product Overview

|  | Harness Style | Harness Model | ① | ② | ③ | ④ | ⑤ | ⑥ | ⑦ | ⑧ | ⑨ | ⑩ | ⑪ | ⑫ | ⑬ | ⑭ | ⑮ | ⑯ | ⑰ | ⑱ | ⑳ | |
|----------------------------------------------------------------------------------|---------------|---------------|---------------------|---------|-----|-----------------------|------------|------------------|----------------|--------|--------------|----------|---------------|----------------|-------------|------------|-----------|-----|------|---------|-------------------|---------|
| | | | Dorsal | Sternal | Hip | Shoulder | Rear Waist | D-ring Extension | Quick Connect | Tongue | Pass-Through | Revolver | Trauma Straps | Lanyard Keeper | SRD Adapter | Seat Sling | Gear Loop | WDS | Belt | Hip Pad | Back and Shoulder | Leg Pad |
| | | | Attachment Elements | | | Buckles and Adjusters | | | Other Elements | | | | | | Pads | | | | | | | |

| | | | | | | | | | | | | | | | | | | | | | | | | | |
|------------------------------------------------------------------------------------|---|---------|---|---|---|--|--|--|---|---|--|---|---|---|---|---|---|--|---|---|---|---|--|--|--|
|  | A | 1113120 | | | | | | | | | | | | | | | | | | | | | | | |
| | | 1113121 | | | | | | | | | | | | | | | | | | | | | | | |
| | | 1113124 | | | | | | | | | | | | | | | | | | | | | | | |
| | | 1113127 | ✓ | | ✓ | | | | | ✓ | | | ✓ | ✓ | ✓ | | | | | ✓ | ✓ | ✓ | | | |
| | | 1113129 | | | | | | | | | | | | | | | | | | | | | | | |
| | | 1113130 | | | | | | | | | | | | | | | | | | | | | | | |
| | | 1113133 | | | | | | | | | | | | | | | | | | | | | | | |
| | | 1113150 | | | | | | | | | | | | | | | | | | | | | | | |
| | | 1113151 | | | | | | | | | | | | | | | | | | | | | | | |
| | | 1113154 | ✓ | ✓ | ✓ | | | | | | | | | | | | | | | | | | | | |
| | | 1113157 | | | | | | | | | | | | | | | | | | | | | | | |
| | | 1113160 | | | | | | | | | | | | | | | | | | | | | | | |
| | | 1113163 | | | | | | | | | | | | | | | | | | | | | | | |
| | | 1113190 | | | | | | | | | | | | | | | | | | | | | | | |
| | | 1113191 | | | | | | | | | | | | | | | | | | | | | | | |
| 1113192 | ✓ | ✓ | ✓ | | | | | | ✓ | | | ✓ | ✓ | ✓ | ✓ | ✓ | ✓ | | ✓ | ✓ | ✓ | | | | |
| 1113193 | | | | | | | | | | | | | | | | | | | | | | | | | |
| 1113194 | | | | | | | | | | | | | | | | | | | | | | | | | |
| 1113195 | | | | | | | | | | | | | | | | | | | | | | | | | |
| 1113196 | ✓ | | | | | | | | ✓ | | | ✓ | ✓ | ✓ | ✓ | | | | ✓ | ✓ | ✓ | | | | |
| 1113197 | | | | | | | | | | | | | | | | | | | | | | | | | |
| 1113199 | | | | | | | | | | | | | | | | | | | | | | | | | |
| 1113244 | ✓ | | | | | | | | ✓ | | | ✓ | ✓ | ✓ | ✓ | | | | ✓ | ✓ | ✓ | | | | |
| 1113290 | | | | | | | | | | | | | | | | | | | | | | | | | |
| 1113291 | ✓ | ✓ | | | | | | | | | | | | | | | | | | | | | | | |
| 1113292 | | | | | | | | | | | | | | | | | | | | | | | | | |
| 1113293 | | | | | | | | | | | | | | | | | | | | | | | | | |
| 1113294 | | | | | | | | | | | | | | | | | | | | | | | | | |
| 1113295 | | | | | | | | | | | | | | | | | | | | | | | | | |
| 1113296 | | | | | | | | | | | | | | | | | | | | | | | | | |
| 1113297 | ✓ | ✓ | | | | | | | ✓ | ✓ | | ✓ | ✓ | ✓ | | | | | ✓ | ✓ | ✓ | | | | |
| 1113298 | | | | | | | | | | | | | | | | | | | | | | | | | |
| 1113299 | | | | | | | | | | | | | | | | | | | | | | | | | |
| 1113305 | | | | | | | | | | | | | | | | | | | | | | | | | |
| 1113306 | ✓ | ✓ | | | | | | | | | | | | | | | | | | | | | | | |
| 1113307 | | | | | | | | | | | | | | | | | | | | | | | | | |
| 1113308 | | | | | | | | | | | | | | | | | | | | | | | | | |

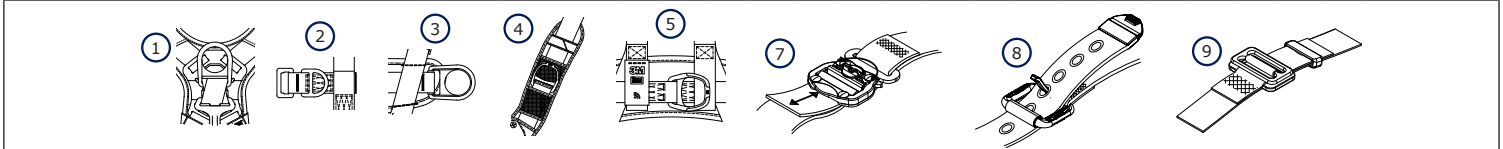
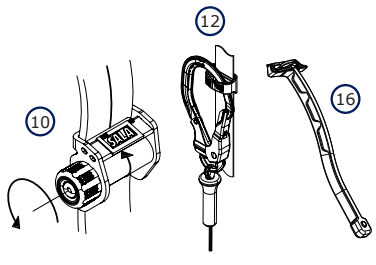
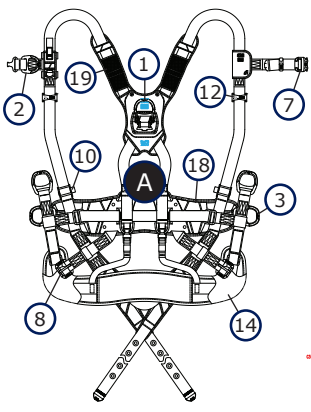

Figure 1 - Product Overview

|  | Harness Style | Harness Model | ① | ② | ③ | ④ | ⑤ | ⑥ | ⑦ | ⑧ | ⑨ | ⑩ | ⑪ | ⑫ | ⑬ | ⑭ | ⑮ | ⑯ | ⑰ | ⑱ | ⑳ | |
|----------------------------------------------------------------------------------|---------------|---------------|---------------------|---------|-----|-----------------------|------------|------------------|----------------|--------|--------------|----------|---------------|----------------|-------------|------------|-----------|-----|------|---------|-------------------|---------|
| | | | Dorsal | Sternal | Hip | Shoulder | Rear Waist | D-ring Extension | Quick Connect | Tongue | Pass-Through | Revolver | Trauma Straps | Lanyard Keeper | SRD Adapter | Seat Sling | Gear Loop | WDS | Belt | Hip Pad | Back and Shoulder | Leg Pad |
| | | | Attachment Elements | | | Buckles and Adjusters | | | Other Elements | | | | | | Pads | | | | | | | |

| | | | | | | | | | | | | | | | | | | | | | | | | | | |
|------------------------------------------------------------------------------------|---|---------|---|---|---|---|--|---|---|---|---|---|---|---|---|---|---|---|---|---|---|---|---|---|--|--|
|  | A | 1113374 | | | | | | | | | | | | | | | | | | | | | | | | |
| | | 1113375 | ✓ | ✓ | ✓ | | | | | ✓ | ✓ | | ✓ | ✓ | ✓ | ✓ | ✓ | | ✓ | ✓ | ✓ | | | | | |
| | | 1113376 | | | | | | | | | | | | | | | | | | | | | | | | |
| | | 1113377 | | | | | | | | | | | | | | | | | | | | | | | | |
| | | 1113378 | | | | | | | | | | | | | | | | | | | | | | | | |
| | | 1113420 | | | | | | | | | | | | | | | | | | | | | | | | |
| | | 1113421 | | | | | | | | | | | | | | | | | | | | | | | | |
| | | 1113422 | ✓ | ✓ | ✓ | | | | | ✓ | ✓ | | ✓ | ✓ | ✓ | | | | | | | | | ✓ | | |
| | | 1113423 | | | | | | | | | | | | | | | | | | | | | | | | |
| | | 1113424 | | | | | | | | | | | | | | | | | | | | | | | | |
| | | 1113444 | | | | | | | | | | | | | | | | | | | | | | | | |
| | | 1113488 | ✓ | ✓ | | | | ✓ | | | | ✓ | ✓ | ✓ | ✓ | ✓ | ✓ | ✓ | | | ✓ | ✓ | ✓ | | | |
| | | 1113704 | | | | | | | | | | | | | | | | | | | | | | | | |
| | | 1113705 | | | | | | | | | | | | | | | | | | | | | | | | |
| | | 1113706 | ✓ | ✓ | | | | | | | ✓ | | | ✓ | ✓ | ✓ | | | | | | ✓ | ✓ | ✓ | | |
| | | 1113707 | | | | | | | | | | | | | | | | | | | | | | | | |
| | | 1113708 | | | | ✓ | | | | | | | | | | | | | | | | | | | | |
| | | 1140126 | | | | | | | | | | | | | | | | | | | | | | | | |
| | | 1140127 | | | | | | | | | | | | | | | | | | | | | | | | |
| | | 1140128 | | | | | | | | | | | | | | | | | | | | | | | | |
| 1140129 | ✓ | | | | | | | | ✓ | ✓ | | ✓ | ✓ | ✓ | | | | | | | | | ✓ | | | |
| 1140130 | | | | | | | | | | | | | | | | | | | | | | | | | | |
| 1140131 | | | | | | | | | | | | | | | | | | | | | | | | | | |
| 1140133 | | | | | | | | | | | | | | | | | | | | | | | | | | |
| 1140134 | | | | | | | | | | | | | | | | | | | | | | | | | | |
| 1140135 | ✓ | ✓ | | | | | | | ✓ | ✓ | | ✓ | ✓ | ✓ | | | | | | | | | ✓ | | | |
| 1140136 | | | | | | | | | | | | | | | | | | | | | | | | | | |
| 1140137 | | | | | | | | | | | | | | | | | | | | | | | | | | |
| 1140139 | | | | | | | | | | | | | | | | | | | | | | | | | | |
| 1140140 | | | | | | | | | | | | | | | | | | | | | | | | | | |
| 1140141 | ✓ | | ✓ | | | | | | ✓ | ✓ | | ✓ | ✓ | ✓ | | | | | | | | | ✓ | | | |
| 1140142 | | | | | | | | | | | | | | | | | | | | | | | | | | |
| 1140143 | | | | | | | | | | | | | | | | | | | | | | | | | | |
| 1140180 | | | | | | | | | | | | | | | | | | | | | | | | | | |
| 1140181 | | | | | | | | | | | | | | | | | | | | | | | | | | |
| 1140182 | ✓ | | ✓ | | | | | | ✓ | ✓ | | ✓ | ✓ | ✓ | | | | | | | | ✓ | ✓ | ✓ | | |
| 1140183 | | | | | | | | | | | | | | | | | | | | | | | | | | |
| 1140184 | | | | | | | | | | | | | | | | | | | | | | | | | | |
| 1140185 | | | | | | | | | | | | | | | | | | | | | | | | | | |
| 1140186 | | | | | | | | | | | | | | | | | | | | | | | | | | |
| 1140187 | | | | | | | | | | | | | | | | | | | | | | | | | | |
| 1140188 | | | | | | | | | | | | | | | | | | | | | | | | | | |
| 1140189 | ✓ | ✓ | ✓ | | | | | | ✓ | ✓ | | ✓ | ✓ | ✓ | | | | | | | | ✓ | ✓ | ✓ | | |
| 1140190 | | | | | | | | | | | | | | | | | | | | | | | | | | |
| 1140191 | | | | | | | | | | | | | | | | | | | | | | | | | | |

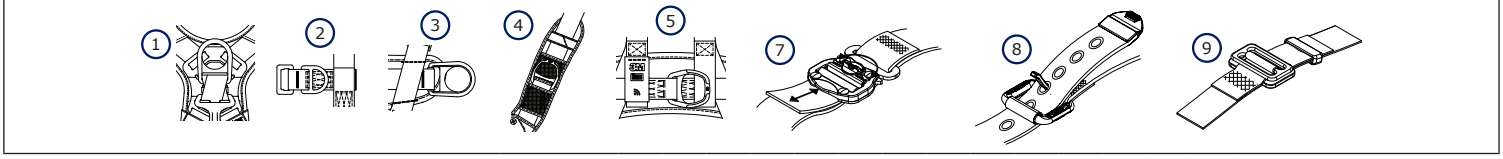
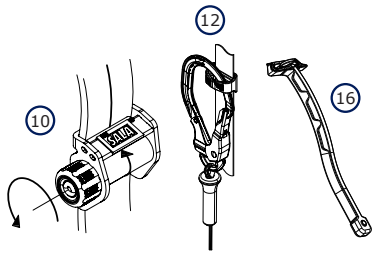
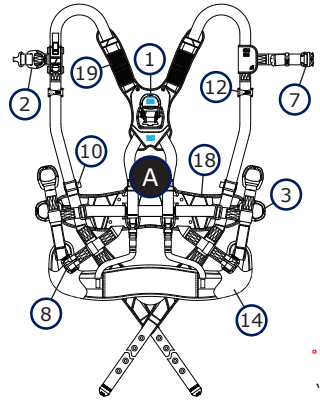

Figure 1 - Product Overview

|  | Harness Style | Harness Model | ① | ② | ③ | ④ | ⑤ | ⑥ | ⑦ | ⑧ | ⑨ | ⑩ | ⑪ | ⑫ | ⑬ | ⑭ | ⑮ | ⑯ | ⑰ | ⑱ | ⑳ | | |
|-----------------------------------------------------------------------------------|----------------------|-----------------------------------------------------|---------------------|---------|-----|----------|------------|------------------|-----------------------|--------|--------------|----------|----------------|----------------|-------------|------------|-----------|-----|------|---------|-------------------|---------|---|
| | | | Dorsal | Sternal | Hip | Shoulder | Rear Waist | D-ring Extension | Quick Connect | Tongue | Pass-Through | Revolver | Trauma Straps | Lanyard Keeper | SRD Adapter | Seat Sling | Gear Loop | WDS | Belt | Hip Pad | Back and Shoulder | Leg Pad | |
| | | | Attachment Elements | | | | | | Buckles and Adjusters | | | | Other Elements | | | | | | Pads | | | | |
|  | A | 1403048 1403049 1403050 1403051 1403052 | ✓ | | | | | | ✓ | ✓ | | ✓ | ✓ | ✓ | ✓ | | | | ✓ | ✓ | ✓ | | |
| | | 1403059 1403060 1403061 1403062 1403063 | ✓ | | ✓ | | | | | ✓ | ✓ | | ✓ | ✓ | ✓ | | | | | ✓ | ✓ | ✓ | |
| | | 1403070 1403071 1403072 1403073 1403074 | ✓ | | | | | | | ✓ | | | ✓ | ✓ | ✓ | | | | | ✓ | ✓ | ✓ | |
| | | 1403088 1403089 1403090 1403091 1403092 | ✓ | | ✓ | | | | | ✓ | ✓ | | ✓ | ✓ | ✓ | | | | ✓ | ✓ | ✓ | ✓ | |
| | | 1403093 1403094 1403095 1403096 1403097 | ✓ | ✓ | ✓ | | | | | ✓ | ✓ | | ✓ | ✓ | ✓ | | | | ✓ | ✓ | ✓ | ✓ | |
| | | 1403098 1403099 1403100 1403101 1403102 | ✓ | | ✓ | | | | | ✓ | | | ✓ | ✓ | ✓ | | | | ✓ | ✓ | ✓ | ✓ | |
| | | 1403103 1403104 1403105 1403106 1403107 | ✓ | ✓ | ✓ | | | | | ✓ | | | ✓ | ✓ | ✓ | | | | ✓ | ✓ | ✓ | ✓ | |
| | | 1403198 1403199 1403200 | ✓ | | | | | | | ✓ | | | ✓ | ✓ | ✓ | | | | | | | | ✓ |
| | | 1403201 1403202 1403203 | ✓ | ✓ | | | | | | ✓ | | | ✓ | ✓ | ✓ | | | | | | | | ✓ |
| | | 1403204 1403205 1403206 | ✓ | ✓ | ✓ | | | | | ✓ | | | ✓ | ✓ | ✓ | | | | | | | | ✓ |
| | | 1403207 1403208 1403209 | ✓ | | ✓ | | | | | ✓ | | | ✓ | ✓ | ✓ | | | | | ✓ | ✓ | ✓ | |

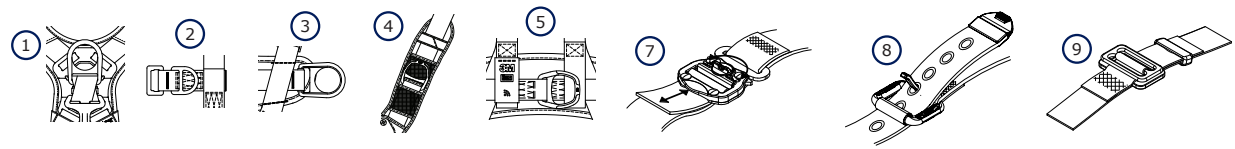
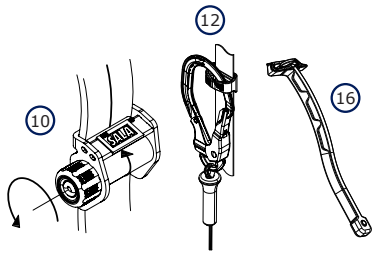
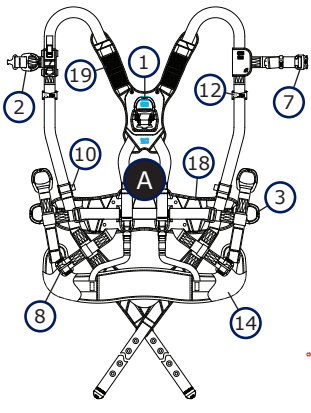
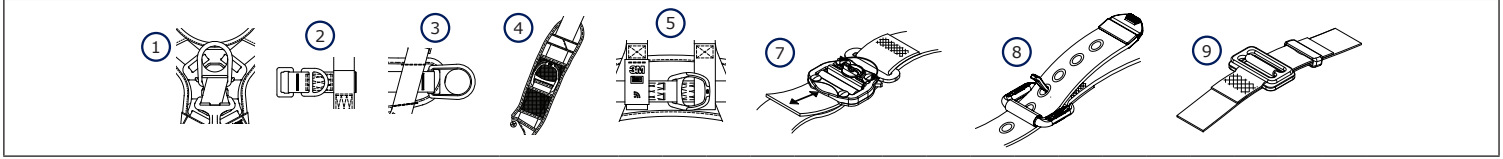

Figure 1 - Product Overview

| | | | | | | | | | | | | | | | | | | | | | |
|----------------------------------------------------------------------------------|----------------------|----------------------|----------------------------|---------|-----|----------|------------------------------|------------------|---------------|--------|-----------------------|----------|---------------|----------------|-------------|-------------|-----------|-----|------|---------|-------------------|
|  | Harness Style | Harness Model | ① | ② | ③ | ④ | ⑤ | ⑥ | ⑦ | ⑧ | ⑨ | ⑩ | ⑪ | ⑫ | ⑬ | ⑭ | ⑮ | ⑯ | ⑰ | ⑱ | ⑳ |
| | | | Dorsal | Sternal | Hip | Shoulder | Rear Waist | D-ring Extension | Quick Connect | Tongue | Pass-Through | Revolver | Trauma Straps | Lanyard Keeper | SRD Adapter | Seat Sling | Gear Loop | WDS | Belt | Hip Pad | Back and Shoulder |
| | | | Attachment Elements | | | | Buckles and Adjusters | | | | Other Elements | | | | | Pads | | | | | |

| | | | | | | | | | | | | | | | | | | | | | | | | |
|-----------------------------------------------------------------------------------|----------|-----------------------------------------------------|---|---|---|--|--|--|---|---|---|---|---|---|---|---|---|---|---|---|---|---|---|---|
|  | A | 1403210 1403211 1403212 | ✓ | ✓ | ✓ | | | | ✓ | | | ✓ | ✓ | ✓ | ✓ | | | | ✓ | ✓ | ✓ | | | |
| | | 1403213 1403214 1403215 | ✓ | ✓ | ✓ | | | | ✓ | | | | ✓ | ✓ | ✓ | | | | | | | | ✓ | |
| | | 1403223 1403224 1403225 1403226 1403227 | ✓ | ✓ | ✓ | | | | ✓ | ✓ | ✓ | | ✓ | ✓ | ✓ | ✓ | | | | | | | ✓ | ✓ |
| | | 1403232 1403233 1403234 1403235 1403236 | ✓ | ✓ | ✓ | | | | ✓ | | | | ✓ | ✓ | ✓ | ✓ | ✓ | ✓ | ✓ | ✓ | ✓ | ✓ | ✓ | ✓ |



SAFETY INFORMATION

Please read, understand, and follow all safety information contained in these instructions, prior to the use of this product. **FAILURE TO DO SO COULD RESULT IN SERIOUS INJURY OR DEATH.**

These instructions must be provided to the user of the equipment. Retain these instructions for future reference.

Intended Use:

This product is used as part of a complete Fall Protection system.

Use in any other application including, but not limited to, material handling, recreational or sports-related activities, or other activities not described in these instructions, is not approved by 3M and could result in serious injury or death.

This product is only to be used by trained users in workplace applications.



WARNING

This product is used as part of a complete Fall Protection system. All users must be fully trained in the safe installation and operation of their complete Fall Protection system. **Misuse of this product could result in serious injury or death.** For proper selection, operation, installation, maintenance, and service, refer to all instruction manuals and manufacturer recommendations. For more information, see your supervisor or contact 3M Technical Services.

- **To reduce the risks associated with using a Full Body Harness which, if not avoided, could result in serious injury or death:**
 - Inspect the product before each use and after any fall event, in accordance with the procedures specified in these instructions.
 - If inspection reveals an unsafe or defective condition, remove the product from service immediately and clearly tag it "DO NOT USE". Destroy or repair the product as required by these instructions.
 - Any product that has been subject to fall arrest or impact force must be immediately removed from service. Destroy or repair the product as required by these instructions.
 - Ensure that Fall Protection systems assembled from components made by different manufacturers are compatible and meet all applicable Fall Protection regulations, standards, or requirements. Always consult a Competent or Qualified Person before using these systems.
 - Ensure the lifeline is kept free from all hazards including, but not limited to: entanglement with users, other workers, moving machinery, other surrounding objects, or impact from overhead objects that could fall onto the lifeline or users.
 - Do not twist, tie, knot, or allow slack in the lifeline.
 - Do not twist, tie, or knot the product.
 - Do not exceed the number of allowable users specified in these instructions.
 - Ensure the harness is appropriately sized, adjusted, donned, and worn as described in these instructions.
 - Ensure the product is configured and installed properly for safe operation as described in these instructions.
 - Use caution when installing, using, or moving the product as moving parts may create pinch points.

- **To reduce the risks associated with working at height which, if not avoided, could result in serious injury or death:**
 - Your health and physical condition must allow you to safely work at height and to withstand all forces associated with a fall arrest event. Consult your doctor if you have questions regarding your ability to use this equipment.
 - Never exceed allowable capacity of your Fall Protection equipment.
 - Never exceed the maximum free fall distance specified for your Fall Protection equipment.
 - Do not use any Fall Protection equipment that fails inspection, or if you have concerns about the use or suitability of the equipment. Contact 3M Technical Services with any questions.
 - Some subsystem and component combinations may interfere with the operation of this equipment. Only use compatible connections. Contact 3M Technical Services before using this equipment in combination with components or subsystems other than those described in these instructions.
 - Use extra precautions when working around moving machinery, electrical hazards, extreme temperatures, chemical hazards, explosive or toxic gases, sharp edges, abrasive surfaces, or below overhead materials that could fall onto you or your Fall Protection equipment.
 - Ensure use of your product is rated for the hazards present in your work environment.
 - Ensure there is sufficient fall clearance when working at height.
 - Never modify or alter your Fall Protection equipment. Only 3M, or persons authorized in writing by 3M, may make repairs to 3M equipment.
 - Before using Fall Protection equipment, ensure a written rescue plan is in place to provide prompt rescue if a fall incident occurs.
 - If a fall incident occurs, immediately seek medical attention for the fallen worker.
 - Only use a full body harness for Fall Arrest applications. Do not use a body belt.
 - Minimize swing falls by working as directly below the anchorage point as possible.
 - A secondary Fall Protection system must be used when training with this product. Trainees must not be exposed to an unintended fall hazard.
 - Always wear appropriate Personal Protective Equipment when installing, using, or inspecting the product.
 - Never work below a suspended load or worker.
 - Always maintain 100% tie-off.

☑ Always ensure you are using the latest revision of your 3M instruction manual. Visit www.3m.com/userinstructions or contact 3M Technical Services for updated instruction manuals.

PRODUCT OVERVIEW:

Figure 1 illustrates available harness models. Harness models are defined by their general construction and available features. Table 1 lists all of the features available with harness models covered by this instruction. "Attachment Elements" serve as connection points for securing a connecting subsystem. "Buckles and Adjuster" enable the harness to be secured and adjusted for proper fit. "Other Elements" includes miscellaneous features that serve a variety of purposes. "Pad" help ensure that the harness is comfortable.

See Table 1 for more information on Component Specifications.

| Harness Styles | | |
|--------------------|-----------------------|--------------------------------------------------------------------------------------------------------------------------------------------------------------------------------------------------------------------------------------------------------------------------------------------|
| Figure 1 Reference | Harness Donning Style | |
| A | Vest-Style | Within Figure 1, "Harness Style" groups models by general construction, while "Harness Model" sorts models by available features. The "style" of your harness is important for determining how to wear it. The "model" is important for determining which features come with your harness. |

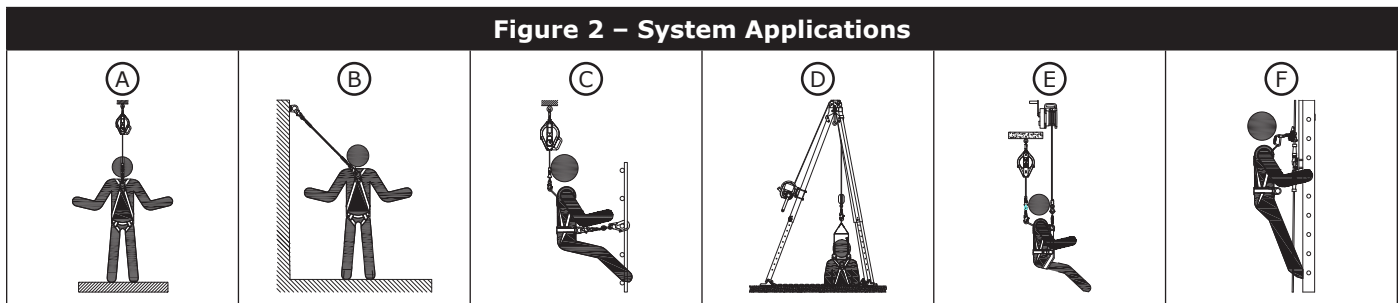

System Applications

Full body harnesses may be used for a variety of system applications. Figure 2 illustrates the applications available to harnesses covered by these instructions. The availability of a specific application is determined by the attachment elements present on your harness, as outlined below. If your harness has one of the attachment elements specified for an application, then it may use that element for that application.

| | Application Type | Attachment Elements |
|-----|--------------------|-------------------------------------------|
| (A) | Fall Arrest | Dorsal, Sternal, Frontal |
| (B) | Restraint | Dorsal, Sternal, Frontal, Hip, Rear Waist |
| (C) | Work Positioning | Frontal, Hip |
| (D) | Rescue | Dorsal, Sternal, Frontal, Shoulder |
| (E) | Controlled Descent | Dorsal, Sternal, Frontal |
| (F) | Climbing | Dorsal, Sternal |

Available Harness Sizes

Figure 1 organizes harness models into groups based on features. All harness models within the same group will include the same features but will vary in sizing options. See the image below for reference. To determine the size of your harness, refer to the topmost portion of your Label Strap (A). Size codes are identified in the "Product Size Codes" legend.

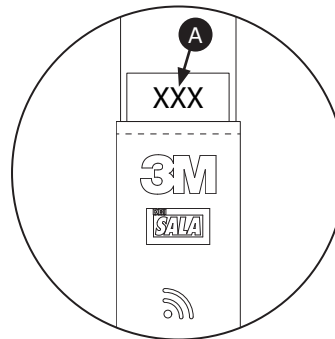

| Product Size Codes | |
|--------------------|------------------|
| S | Small |
| M | Medium |
| L | Large |
| XL | Extra Large |
| 2XL | Extra Large (x2) |
| 3XL | Extra Large (x3) |

Harness Capacity

The user of this full body harness must have a combined weight (including clothing, tools, etc.) meeting the requirements set by the applicable standard or regulation. Always ensure the full body harness is adjusted to fit the user properly.

| | |
|-------------|--------------------------------------|
| ANSI | 130 lb. to 310 lb. (59 kg to 140 kg) |
| OSHA | Up to 420 lb. (190 kg) |

Before using this equipment, record the product identification information from the ID label in the "Inspection and Maintenance Log" at the back of this manual.

Table 1 - Product Specifications

| System Specifications | |
|---------------------------------|------------------------------------------------------------------------------------------------------------------------|
| Standards: | Each product model is certified to, or conforms with, the applicable standards and regulations listed within Figure 1. |
| D-ring Extension Length: | 1.5 ft. (45.7 cm) |

| Component Specifications | | | |
|---------------------------------|---------------------------|----------------------------------|----------------------------------------------------------------------------------------------|
| Figure 1 Category | Figure 1 Reference | Description | Materials |
| Attachment Elements | ① | Dorsal D-ring | Alloy steel and aluminum alloy - 22.2 kN (5,000 lbf) Tensile Strength |
| | ② | Sternal D-ring | Aluminum alloy - 22.2 kN (5,000 lbf) Tensile Strength |
| | ③ | Hip D-rings | Aluminum alloy - 22.2 kN (5,000 lbf) Tensile Strength |
| | ④ | Shoulder D-rings | Aluminum alloy - 22.2 kN (5,000 lbf) Tensile Strength |
| | ⑤ | Rear Waist D-ring | Aluminum alloy - 22.2 kN (5,000 lbf) Tensile Strength |
| | ⑥ | D-ring Extension (Dorsal) | Alloy steel and polyester - 22.2 kN (5,000 lbf) Tensile Strength |
| Buckles and Adjusters | ⑦ | Quick Connect Buckles | Steel, stainless steel, and alloy steel - 18 kN (4,000 lbf) Tensile Strength |
| | ⑧ | Tongue Buckles | Aluminum alloy - 18 kN (4,000 lbf) Tensile Strength |
| | ⑨ | Pass-Through Buckles | Alloy steel - 18 kN (4,000 lbf) Tensile Strength |
| | ⑩ | Revolver Adjusters | Aluminum alloy, stainless steel, alloy steel, and nylon - 18 kN (4,000 lbf) Tensile Strength |
| Other Elements | ⑪ | Suspension Trauma Straps | Polyester webbing with polyester thread |
| | ⑫ | Lanyard Keeper | Injection-molded nylon |
| | ⑬ | SRD Adapter | Aluminum alloy |
| | ⑭ | Seat Sling | Blend of nylon and polyester |
| | ⑮ | Gear Loop | Polyester, nylon, PVC, and alloy steel |
| | ⑯ | Weight Distribution System (WDS) | Injection-molded nylon |
| | ⑰ | Belt | Polyester |
| Pads | ⑱ | Hip Pad | Blend of nylon and polyester |
| | ⑲ | Back and Shoulder Pad | Blend of nylon and polyester |

Additional Materials

| Description | Materials |
|--------------------|------------------------------------------------|
| Webbing | Polyester - 27 kN (6,000 lbf) Tensile Strength |
| Stitching | Polyester thread on polyester webbing |
| Label Covers | Blend of nylon and polyester |

| Performance Specifications | |
|------------------------------------|--------------------------------------------------------------------------------------------------------------------------|
| Maximum Free Fall Distance: | See the instruction manual of your connecting subsystem for more information on Maximum Free Fall Distance requirements. |
| Maximum Arresting Force: | See the instruction manual of your connecting subsystem for more information on Maximum Arresting Force requirements. |
| Maximum Harness Stretch: | 1.5 ft. (0.45 m) |

1.0 PRODUCT APPLICATION

- 1.1 PURPOSE:** Full body harnesses provide users with the means to connect to Fall Protection systems. The attachment elements of the full body harness serve as connection points for the connecting subsystem, which secures the user to an anchorage point. Full body harnesses may be used for a variety of Fall Protection systems. System application is determined by the make of your full body harness and the attachment elements present on your harness. See the "Product Overview" and Figure 2 for a full list of Fall Protection applications available for your full body harness model.
- 1.2 STANDARDS:** Your product conforms to the national or regional standards identified on the front cover of these instructions. If this product is resold outside the original country of destination, the re-seller must provide these instructions in the language of the country in which the product will be used.

For more information on certification or conformance requirements, refer to the applicable standards and regulations listed for your product (e.g. the ANSI/ASSP Z359 Fall Protection codes).

- 1.3 TRAINING:** This equipment must be installed and used by persons trained in its correct application. These instructions are to be used as part of an employee training program as required by national, regional, or local standards. It is the responsibility of the users and installers of this equipment to ensure they are familiar with these instructions, trained in the correct care and use of this equipment, and are aware of the operating characteristics, application limitations, and consequences of improper use of this equipment.
- 1.4 RESCUE PLAN:** When using this equipment and connecting subsystems, the employer must have a written rescue plan and the means to implement and communicate that plan to users, authorized persons, and rescuers. A trained, on-site rescue team is recommended. Team members should be provided with the equipment and techniques necessary to perform a successful rescue. Training should be provided on a periodic basis to ensure rescuer proficiency. Rescuers should be provided with these instructions. There should be visual contact or means of communication with the person being rescued at all times during the rescue process.

2.0 SYSTEM REQUIREMENTS

- 2.1 CAPACITY:** The user capacity of a complete Fall Protection system is limited by its lowest-rated maximum capacity component. For example, if your connecting subsystem has a capacity that is less than your harness, you must comply with the capacity requirements of your connecting subsystem. See the manufacturer instructions for each component of your system for capacity requirements.
- 2.2 CONNECTING SUBSYSTEMS:** Connecting subsystems (self-retracting devices, energy-absorbing lanyards, lifeline subsystems, etc.) must be suitable for your application. Refer to the subsystem manufacturer instructions for additional information.
- 2.3 ENVIRONMENTAL HAZARDS:** Use of this equipment in areas with environmental hazards may require additional precautions to prevent injury to the user or damage to the equipment. Hazards may include, but are not limited to: high heat, chemicals, corrosive environments, high voltage power lines, explosive or toxic gases, moving machinery, sharp edges, or overhead materials that may fall and contact the user or equipment. Contact 3M Technical Services for further clarification.
- 2.4 EXTENDED SUSPENSION:** A full body harness should not be used in extended suspension applications. Extended suspension can cause suspension trauma. If the user is going to be suspended for an extended length of time, it is recommended that some form of seat support be used. 3M recommends a seat board, suspension work seat, seat sling, or a boatswain chair. Contact 3M Technical Services for more information.
- 2.5 COMPONENT COMPATIBILITY:** 3M equipment is designed for use with 3M equipment. Use with non-3M equipment must be approved by a Competent Person. Substitutions made with non-approved equipment may jeopardize equipment compatibility and may affect the safety and reliability of your Fall Protection system. Read and follow all instructions and warnings for all equipment prior to use.
- 2.6 CONNECTOR COMPATIBILITY:** Connectors are compatible with connecting elements when the size and shape of either component does not cause the connector to inadvertently open, regardless of orientation. Connectors must comply with applicable standards. Connectors must be fully closed and locked during use.

3M Connectors (snap hooks and carabiners) are designed to be used only as specified in each instruction manual. Ensure connectors are compatible with the system components to which they are connected. Do not use equipment that is non-compatible. Use of non-compatible components may cause the connector to unintentionally disengage (see Figure 3). If the connecting element to which a connector attaches is undersized or irregular in shape, a situation could occur where the connecting element applies a force to the gate of the connector (A). This force could then cause the gate to open (B), disengaging the connector from the connecting element (C).

2.8 MAKING CONNECTIONS: All connections must be compatible in size, shape, and strength. See Figure 4 for examples of inappropriate connections. Do not attach snap hooks and carabiners:

- A. To a D-ring to which another connector is attached.
- B. In a manner that would result in a load on the gate. Large-throat snap hooks should not be connected to standard-size D-Rings or other connecting elements, unless the snap hook has a gate strength of 16 kN (3,600 lbf) or greater.
- C. In a false engagement, where size or shape of the connector or connecting element is not compatible and, without visual confirmation, would seem to be fully engaged.
- D. To each other.
- E. Directly to webbing or rope lanyard or tie-back material, unless the instruction manuals for both the lanyard and connector specifically allow such a connection.
- F. To any object whose size or shape does not allow the connector to fully close and lock, or that could cause connector roll-out.
- G. In a manner that does not allow the connector to align properly while under load.

2.8 LANYARD PARKING ATTACHMENT: Figure 5 illustrates lanyard parking. The lanyard parking attachment is for attaching the free end of a lanyard or harness-mounted Self-Retracting Device when not connected to an anchorage connection point for purposes of Fall Protection. Lanyard parking attachments must never be used as a Fall Protection attachment element on the harness for connecting a lanyard or Self-Retracting Device (A).

When not connected to an anchorage connection point, an unconnected lanyard leg must be properly parked on the Harness (B) or secured in the user's hands as in 100-percent tie-off applications (C). Free-hanging Lanyard Legs (D) can trip the user or catch on surrounding objects resulting in a fall.

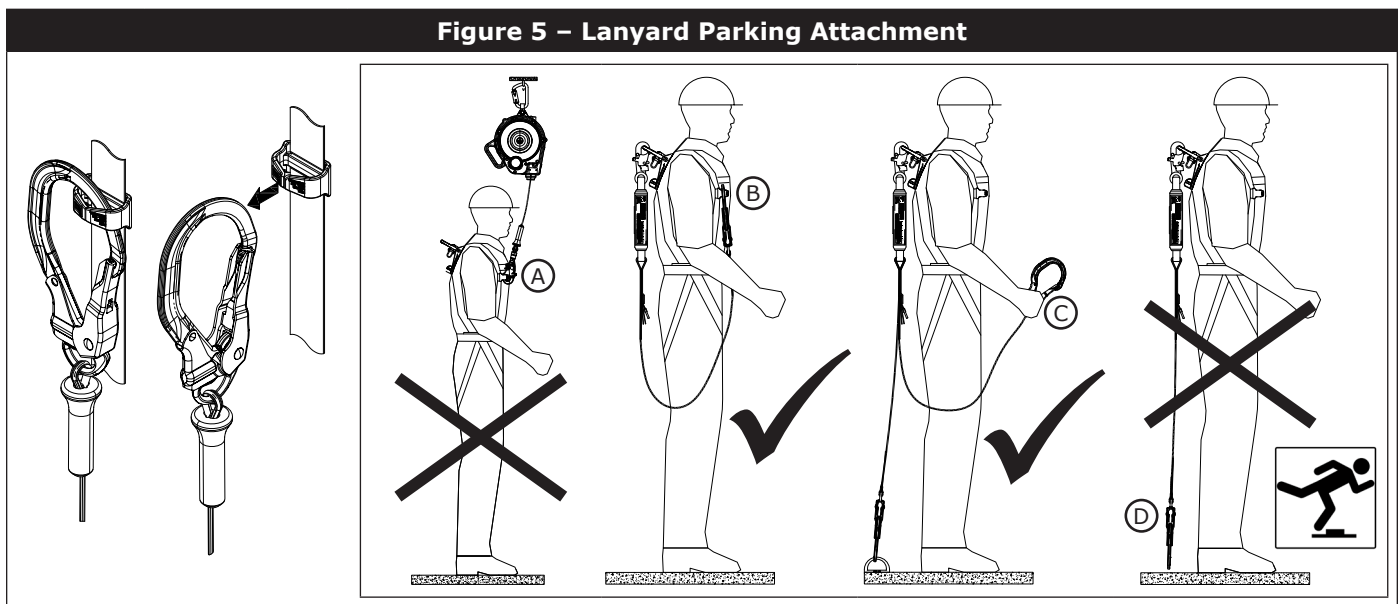
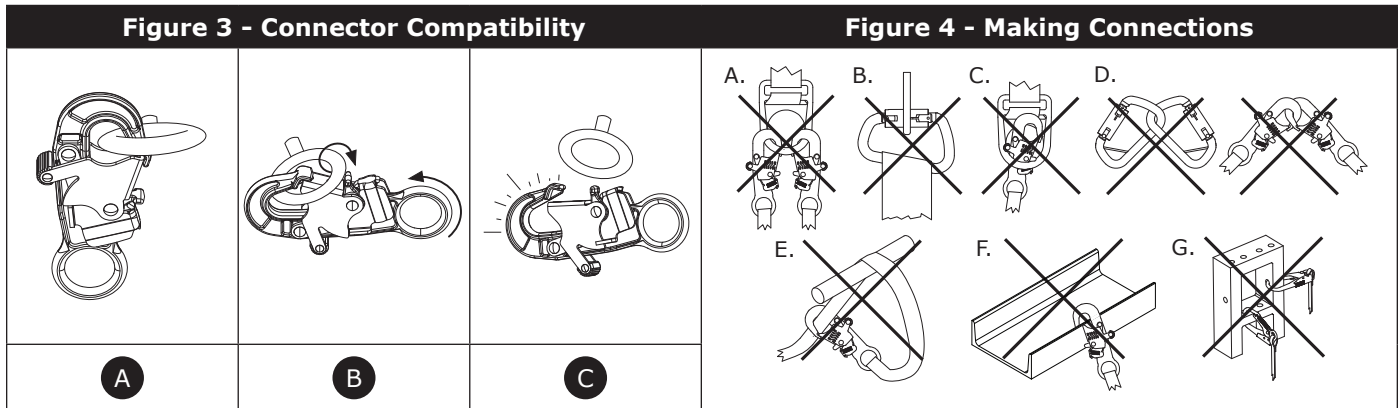

3.0 INSTALLATION

3.1 OVERVIEW: Full body harnesses are to be used as part of a Fall Protection system. Ensure each component of your Fall Protection system is installed per the manufacturer instructions.

3.2 PLANNING: Plan your Fall Protection system before installation. Account for all factors that may affect your safety before, during, and after a fall. Consider all requirements and limitations specified in these instructions.

A. ANCHORAGE: Select an anchorage capable of sustaining the static load requirements of the intended Fall Protection application. See the manufacturer instructions for each component of your Fall Protection system for more information. The anchorage location should address all requirements specified in these instructions.

B. SHARP EDGES: Avoid working where system components may be in contact with, or scrape against, unprotected sharp edges and abrasive surfaces. All sharp edges and abrasive surfaces should be covered with protective material.

C. CONNECTING SUBSYSTEMS: Connecting subsystems used with the harness must be suitable for your system application. See the Product Overview and Figure 2 for more information, as well as the manufacturer instructions for your connecting subsystem.

D. HARNESS STRETCH: Some amount of harness stretch should be expected when using this product as part of a Fall Arrest system during fall arrest. See "Table 1 – Product Specifications" for how much harness stretch should be expected when using this product. Harness stretch should be added to all fall clearance requirements for your system, unless it is already accounted for by the connecting subsystem or another component. See the manufacturer instructions of your connecting subsystem for more information on fall clearance requirements.

Maximum harness stretch is determined by the applicable standard or regulation.

E. D-RING EXTENSIONS: When used, D-ring extensions increase fall clearance requirements by increasing the amount of free fall present in the Fall Arrest system. The length of the D-ring extension must be added to all fall clearance requirements as part of the system's free fall value. If there is an upper limit for free fall within the system, then system use must be adjusted to remain below that limit. See Table 1 for the length of your D-ring extension. See the manufacturer instructions of your connecting subsystem for more information on free fall and fall clearance requirements.

Never use D-ring extensions in leading edge applications.

3.3 BEFORE INSTALL: Before donning your harness, you should do the following.

- Inspect the harness per the "Inspection and Maintenance Log".
- Disconnect all buckles.
- Straighten all harness straps so that none are twisted.
- Empty your pockets. Items left in pockets may prevent your harness from properly securing or cause injury in the event of a fall.

3.4 DONNING THE HARNESS: Donning a full body harness is a procedure with multiple steps. Each step should be followed carefully. Different styles of harnesses may include different sets of features, resulting in different steps for donning. See Figure 6 for reference. See Figure 1 to identify your harness style.

A. VEST-STYLE HARNESSES: "Vest style" harnesses include two torso straps and a chest buckle. See Figure 6A for reference.

- 1. Put on the harness.** Lift the harness by its dorsal D-ring. Slip on the torso straps, then let the harness hang loosely from your shoulders. Position the chest buckle on your chest as shown. Verify no straps are twisted.
- 2. Connect the harness buckles.** Secure the leg straps first, then secure the chest buckle. If present, secure the waist belt buckle.

See Section 3.6 for buckle instructions. See Figure 1 for which buckles are on your harness.

- 3. Adjust the harness for proper fit.** Check all adjustable features on your harness, including buckles and adjusters. Position the sub-pelvic strap and adjust your leg straps, then adjust your torso straps. All harness straps should have a snug, comfortable fit.

See Section 3.7 for adjuster instructions. See Figure 1 for which adjusters are on your harness.

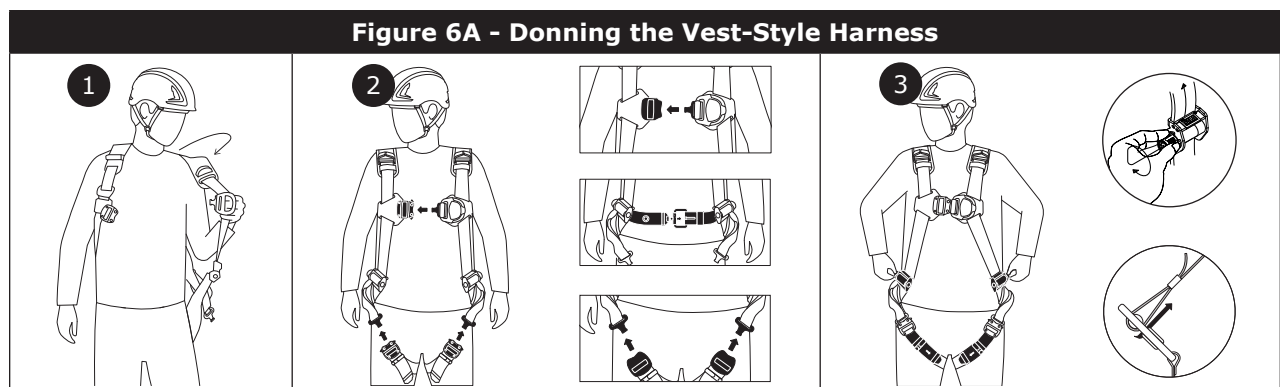

3.5 EQUIPMENT CHECK: Use these equipment checks to verify that your harness is properly installed. See Figure 7 for reference.

The user should verify with a second trained user that their harness has been properly installed.

- A. All buckles and adjusters are secure.** Check each harness strap to verify that all buckles are connected, and that each adjuster is locked in place.
- B. All harness straps are comfortably snug.** Check the fit of your harness straps. Ensure no harness straps are twisted. Verify that the sub-pelvic strap (X) is positioned just beneath the buttocks.
- C. All D-rings and other attachment elements are properly positioned.** Verify that the dorsal D-ring, if present, is positioned between your shoulder blades.
- D. All harness straps are properly stored.** Secure adjustment straps with strap keepers, where present. Move all keepers to strap end.
- E. All harness pads are comfortable, if present.** Shoulder pads are along upper back and leg pads are against buttocks. Pads should remain largely in place and resist sliding.

Figure 7 - Equipment Check

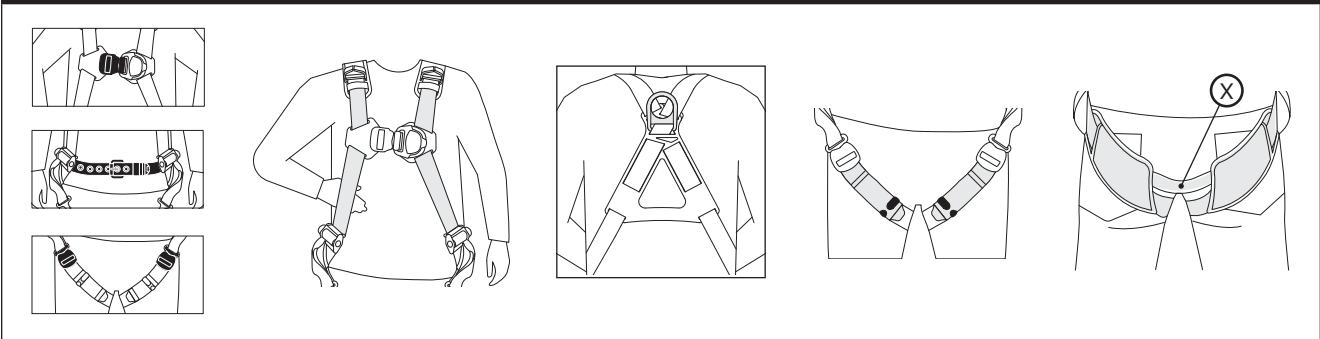

3.6 CONNECTING THE BUCKLES: 3M Harnesses are equipped with a variety of buckles for fastening and adjusting harness straps. See Figure 8 for reference. See Figure 1 for which buckle types are on your harness.

A. QUICK CONNECT BUCKLES (FIGURE 8A)

1. **Engage:** Insert the tab into the receptor. You should hear a click when the buckle is secured.
2. **Disengage:** Squeeze the lock levers on either side of the receptor. Pull the tab out of the receptor.
3. **Adjust:** Turn and hold the buckle 90 degrees from the harness strap. To shorten webbing, pull down on the adjustment strap. To lengthen webbing, pull upwards on the buckle.

Figure 8A - Quick Connect Buckles

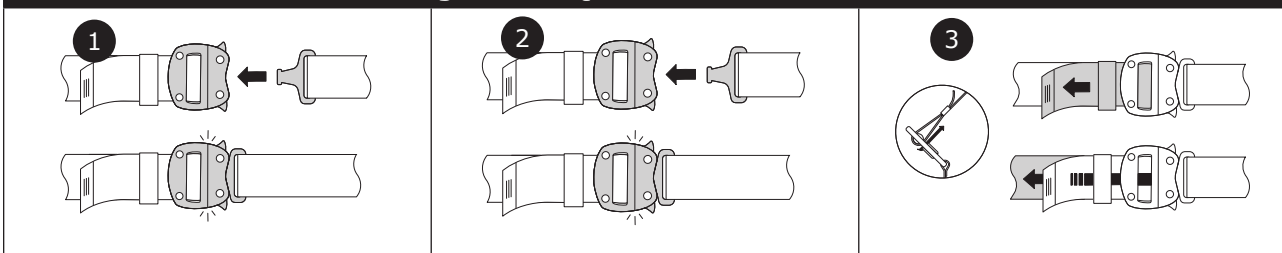

B. TONGUE BUCKLES (FIGURE 8B)

1. **Engage:** Insert the tongue through the buckle frame. Insert the buckle tab through one of the tongue grommets, then insert the tongue through the strap keeper to secure.
2. **Disengage:** Remove the tongue from the strap keeper. Pull back on the tongue while also pulling back on the buckle tab, until the two are released. Remove the tongue from the buckle frame.
3. **Adjust:** Secure the tab through different grommets to adjust fit. Move the tab inward to tighten, out to loosen.

Figure 8B - Tongue Buckles

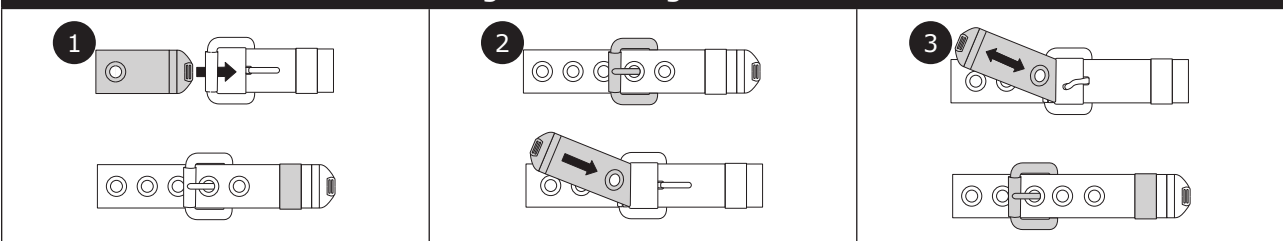

C. PASS-THROUGH BUCKLES (FIGURE 8C)

1. **Engage:** Insert the male buckle through the slot in the female buckle. Tighten the harness strap so that the male

buckle is flush against the female buckle.

2. **Disengage:** Loosen the harness strap so that the male buckle separates from the female buckle. Once separated, pull the male buckle out through the female buckle.
3. **Adjust:** Turn and hold the buckle 90 degrees from the harness strap. To shorten webbing, pull down on the adjustment strap. To lengthen webbing, pull upwards on the buckle.

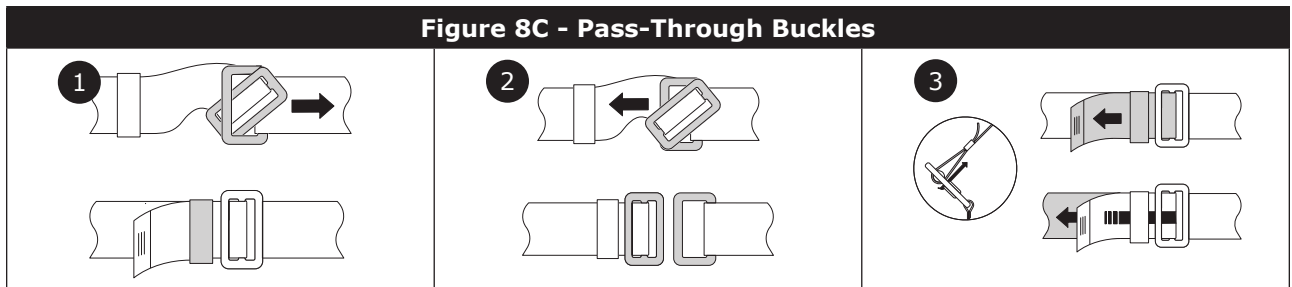

- 3.7 USING THE ADJUSTERS:** 3M Harnesses are equipped with a pair of adjusters for modifying the shoulder straps. See Figure 9 for reference. See Figure 1 for which adjuster types are on your harness.

A. REVOLVER ADJUSTERS (FIGURE 9A)

1. **Tighten:** Rotate the ratchet knob towards your body to tighten.
2. **Loosen:** Pull the ratchet knob out, then rotate the knob away from your body to loosen.

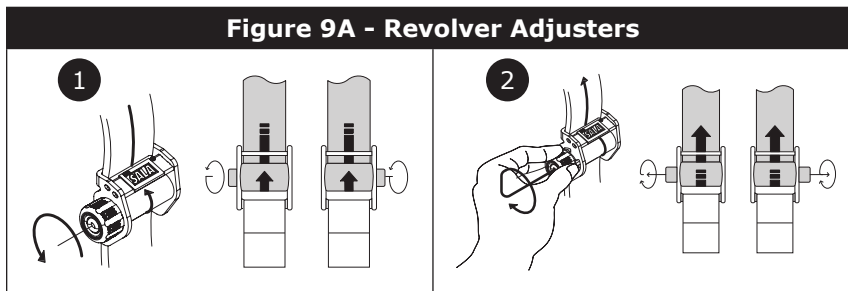

B. PARACHUTE ADJUSTERS (FIGURE 9B)

1. **Adjust:** Turn and hold the adjuster 90 degrees from the harness strap. To shorten webbing, pull down on the adjustment strap. To lengthen webbing, pull upwards on the adjuster.
2. **Store:** Place the strap keeper at the end of the adjustment strap to secure.

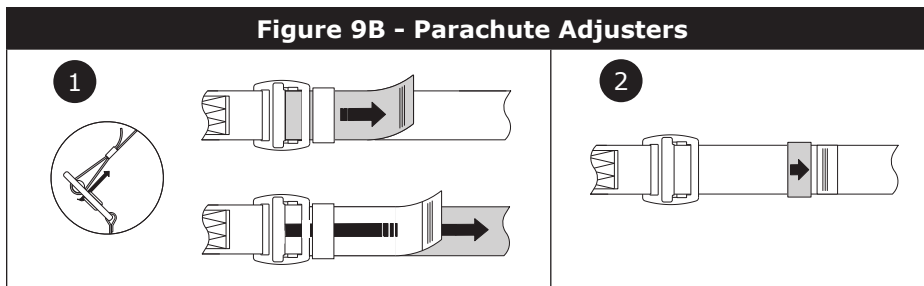

- 3.8 INSTALLING A HARNESS-MOUNTED SRD:** Harness-mounted SRDs are secured directly to harnesses by means of a harness interface. Harness interfaces are a type of connector specially designed for this purpose. In general, there are two types of harness interface: straight-pin and carabiner. Instructions for each style are provided below.

Instructions may vary per harness interface model. For more information on how to use your harness interface, see the manufacturer instructions for the harness interface or for the product it was provided with.

Do not remove the backplate from the harness when installing a harness-mounted SRD.

A. STRAIGHT-PIN INTERFACE: Straight-pin harness interfaces include a locking pin for securing to the harness. Straight-pin interfaces may be used with Single-SRD or Twin-SRD formats, depending on the harness interface used. See Figure 10 for reference.

1. Press both Locking Buttons (A) on the front of your harness interface to open. With the Locking Buttons held down, remove the Locking Pin (B) from the harness interface.
2. Thread the Locking Pin (B) behind both Harness Straps (C), capturing the straps as you reinsert the pin into the harness interface. An audible click should be heard when the Locking Pins are reengaged.
3. Verify that the harness interface is secure and that both Harness Straps (C) are captured by the harness interface.

B. CARABINER INTERFACE: Carabiner interfaces are carabiners that function as harness interfaces. Carabiner interfaces may be used with Single-SRD or Twin-SRD formats, although methods will vary slightly. See Figure 11 for reference, which shows how to install the carabiner interface using a Twin-SRD format.

1. Open the Gate (A) of the carabiner interface. Slide the SRD (C) over the open Arm (B) of the carabiner. Then, slide the SRD to the opposite side of the carabiner.
2. Hold the Gate (A) of the carabiner interface open, then slide the open Arm (B) behind and around both Harness Straps (D), capturing the straps within the carabiner interface.
3. Thread the second SRD (E) onto the open Arm (B) of the carabiner interface. Then, release the Gate to close and secure the carabiner interface.
4. Verify that the carabiner interface is secure and that both Harness Straps (D) are captured by the interface.

For Single-SRD formats, only one SRD should be attached to the carabiner interface. In this format, the carabiner interface may be secured as outlined above, or directly to your Dorsal D-ring instead. If securing to your Dorsal D-ring, do not capture the harness straps.

Certain harness models covered in these instructions include additional features for securing harness-mounted SRDs. See below for how these features should be used:

- **INTERFACE LOOP:** The Interface Loop (X) is part of the backplate for certain harness models. The Interface Loop serves as a secure connection point for harness interfaces behind the harness straps. See Figure 12 for reference. To connect to the Interface Loop, the user should route their harness interface or its locking pin through the Interface Loop as part of capturing the harness straps.
- **SRD ADAPTER:** Certain harness models include an external SRD Adapter (Y) for securing harness-mounted SRDs. See Figure 1 for a list of models with SRD Adapters. When connecting to this type of SRD Adapter, the user does not need to capture the harness straps. Instead, the user should route their harness interface directly through the SRD Adapter. See Figure 13 for reference.

Only straight-pin harness interfaces may be used with the SRD Adapter. The user should route the locking pin of their harness interface through the connection loop of the SRD Adapter.

Figure 10 - Straight-Pin Interface

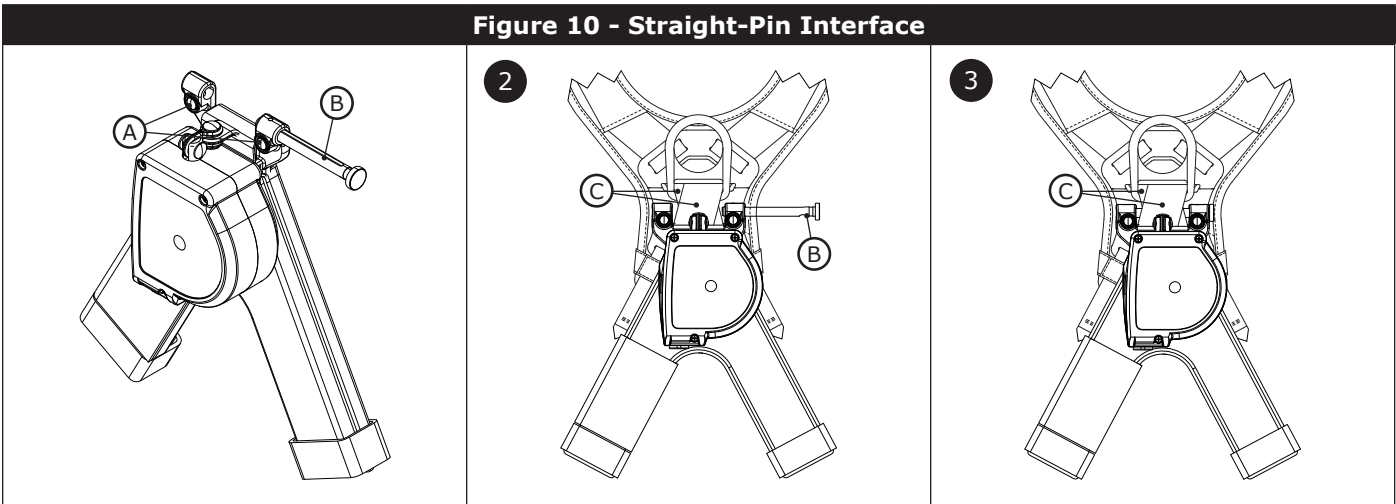

Figure 11 - Carabiner Interface

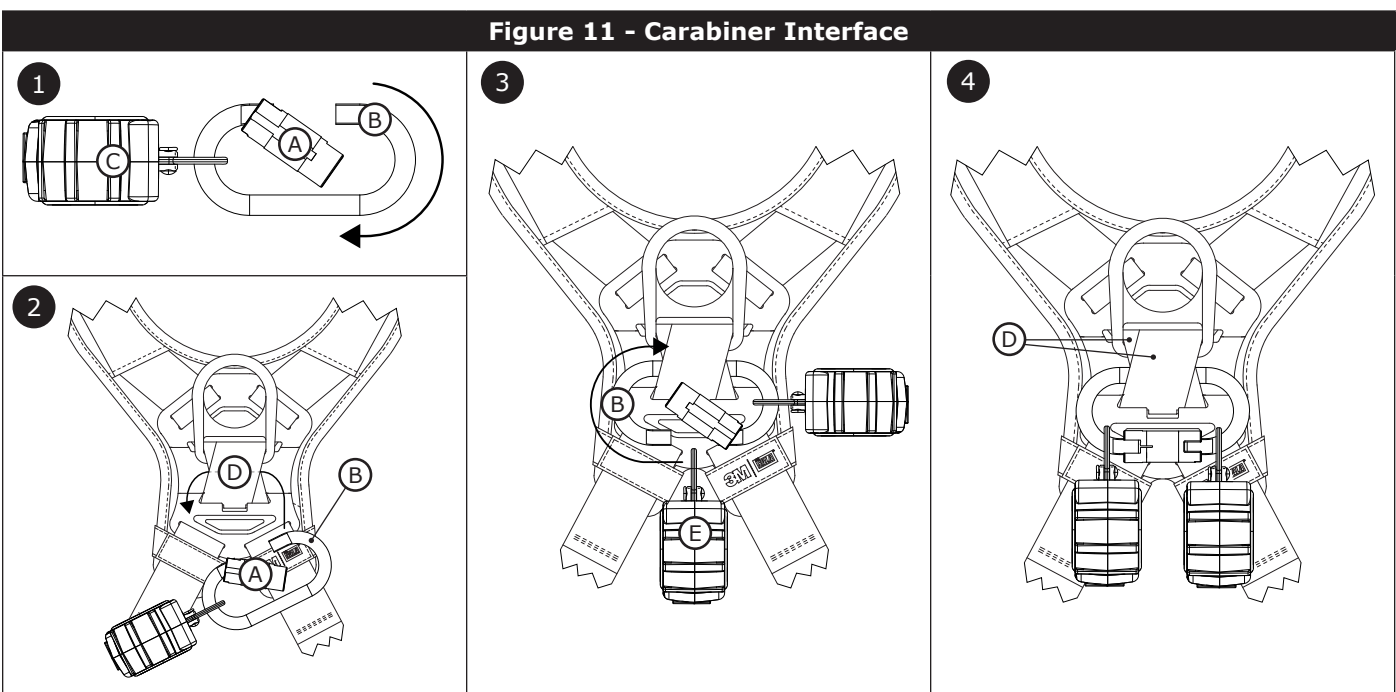

Figure 12 - Interface Loop

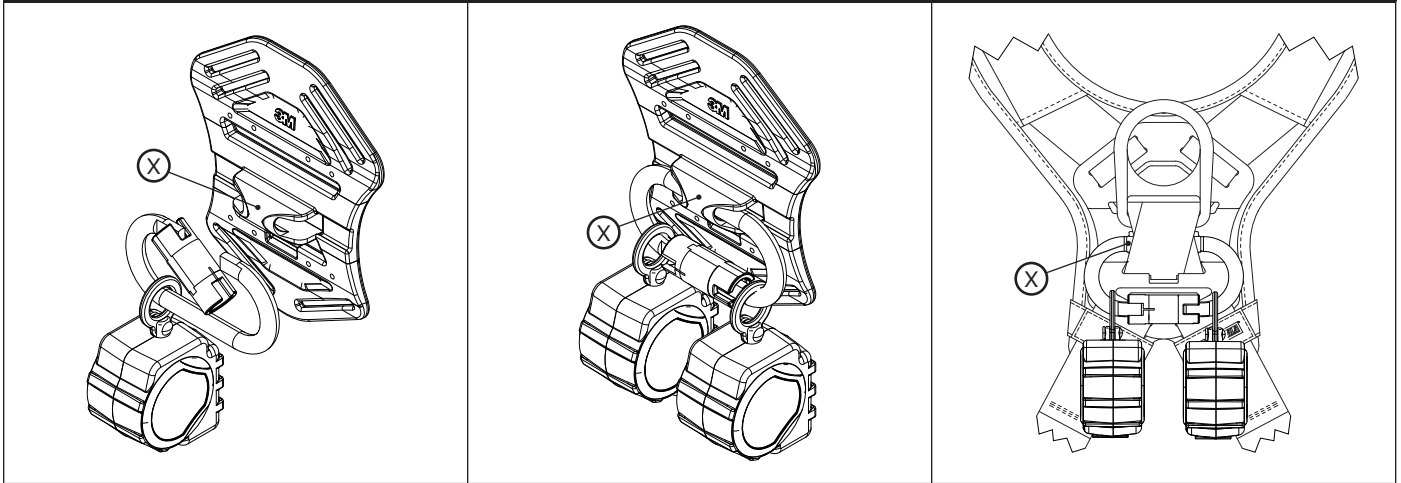
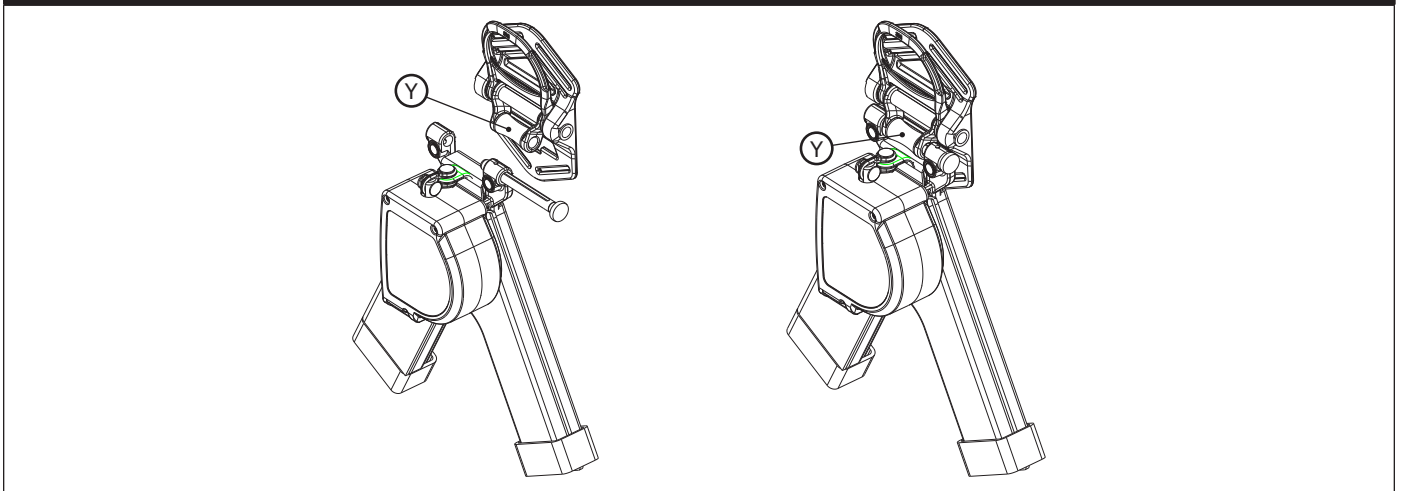
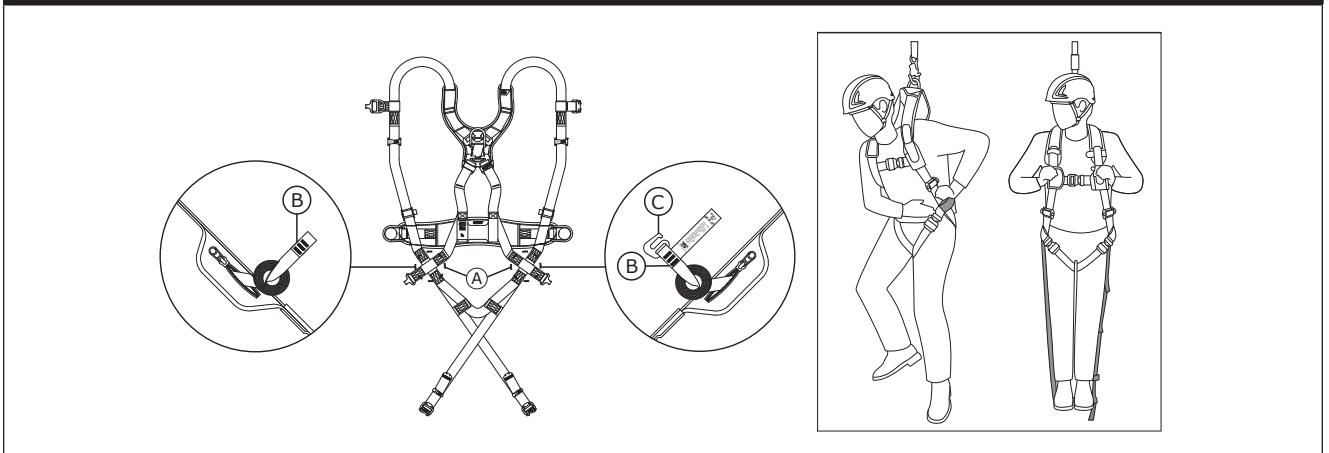

Figure 13 - SRD Adapter



- 3.9 DEPLOYING THE SUSPENSION TRAUMA STRAPS:** Figure 14 illustrates deployment of the Suspension Trauma Straps. In the event of a fall, the Suspension Trauma Straps should be used by the fallen worker to alleviate suspension trauma. To deploy the Suspension Trauma Straps on your harness:
1. Locate the Suspension Trauma Straps (A) on your harness. The Suspension Trauma Straps should be located in a zipped container on your front, near the two intersection points of the leg straps.
 2. Deploy the Suspension Trauma Straps by opening the zipped compartments located on the containers' sides. Guide the Straps (B) out from within each container to a length long enough for you to stand upon. Bring the two Straps together and secure them to each other by means of the Strap Hook (C).
 3. Extend the connected Straps as necessary to create a length of webbing for you to stand upon. Press your heels upon either side of the connection point and stand up straight. This should transfer a significant amount of weight to the user's feet, diminishing the likelihood of suspension trauma.

Figure 14 - Activating the Trauma Straps



3.10 SECURING LANYARDS WITH CHOKER LOOPS: Some lanyard models include choker loops for connecting to harnesses. Choker loops are web loops that are designed to choke the lanyard onto a harness before securing to an anchorage point. See Figure 15 for reference. To secure a lanyard with a choker loop:

1. Insert the lanyard choker loop through the dorsal attachment element on the harness. This may be a D-ring or another web loop that is part of the harness.
2. Insert the anchoring end of the lanyard through the choker loop so that the lanyard encloses the harness attachment element.
3. Pull the lanyard through until its choker loop tightly cinches the harness attachment element.

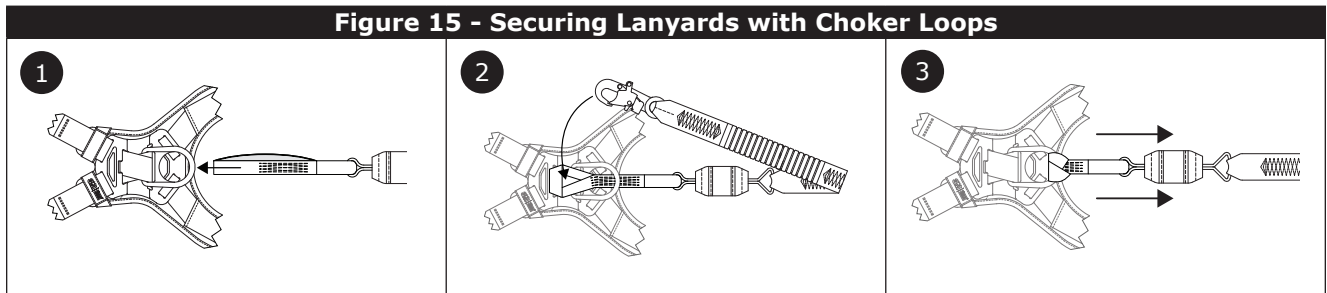

3.11 ATTACHING THE WEIGHT DISTRIBUTION SYSTEM: Figure 16 illustrates attachment of the Weight Distribution System (WDS). When secured, the WDS lessens the stress caused by prolonged harness wear, moving the center of weight from your shoulders to the WDS on your back. To attach the WDS to a compatible harness:

To remove the Weight Distribution System, follow this procedure in reverse.

1. Insert the Weight Distribution Bar (A) within the Belt Mount (B) of your harness. Verify that the Tail (C) is secured in place; there should be an audible click as the spring-loaded pin of the Tail locks into place.
2. Identify the Weight Distribution Backplate (D). Verify that it is installed on the harness.
3. Insert the Head (F) of the Weight Distribution Bar through the Mounting Point (E) of the Backplate. Loop the Head of the Bar around the Webbing (G) of your harness.
4. When connecting the Bar, insert the Front Teeth (H) of the Bar through the Mounting Point first.
5. Once the Front Teeth are inserted, secure the Bar in place by engaging the Bottom Clip (I). The Weight Distribution Bar should now be securely locked onto the Backplate.

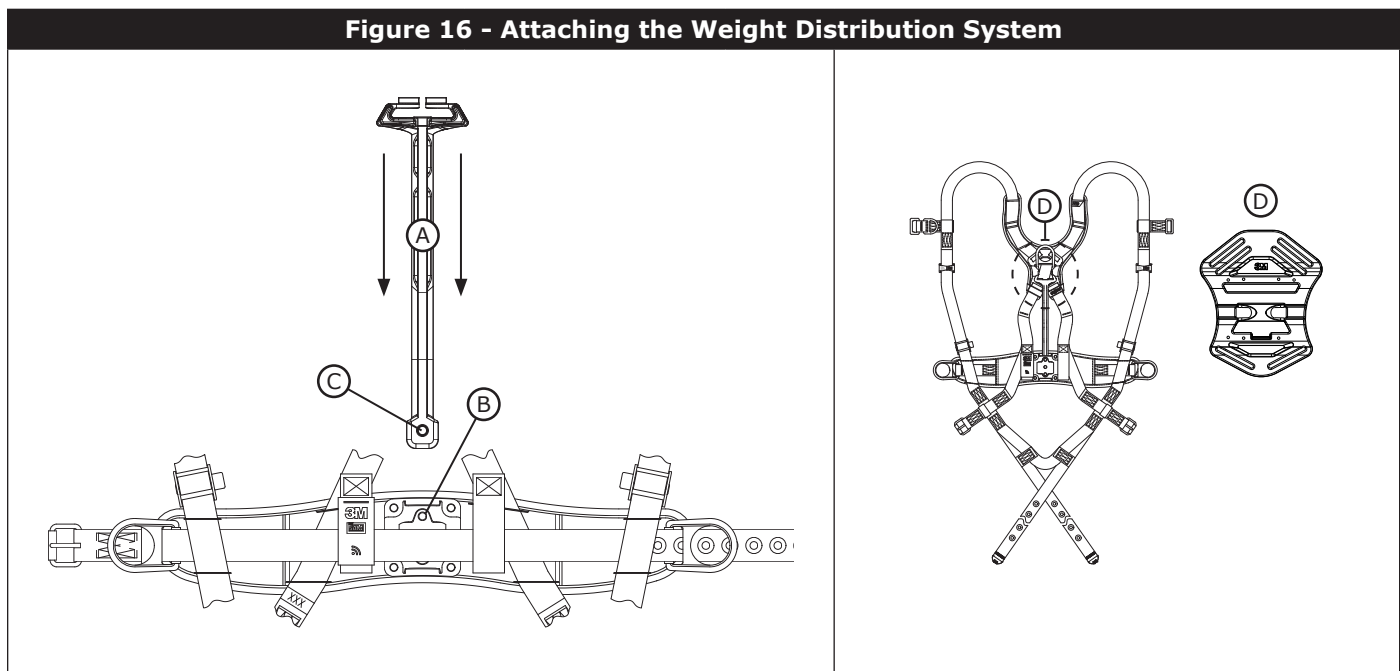
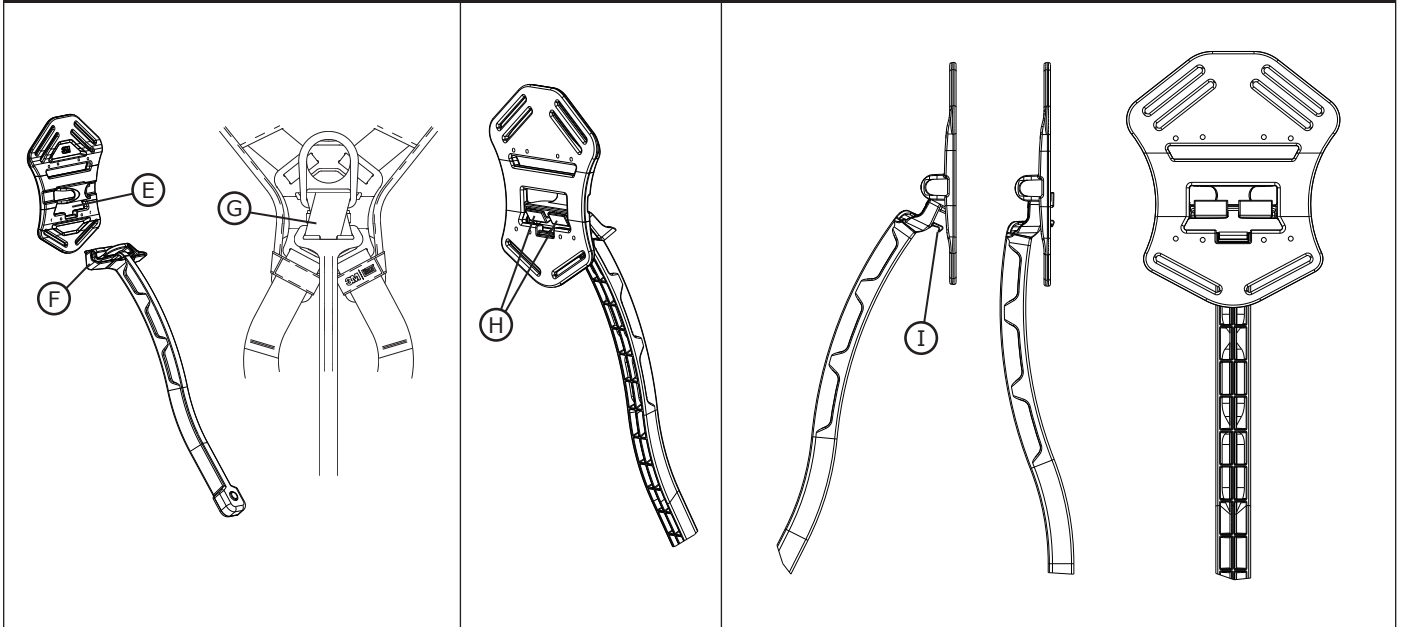

Figure 16 - Attaching the Weight Distribution System



3.12 REMOVING THE BACK AND SHOULDER PAD: The Back and Shoulder Pad may be removed from the harness for cleaning or adjustment. The Back and Shoulder Pad of the harness is secured to the Harness by Velcro straps along each leg of the harness. See Figure 17 for reference. To remove the Back and Shoulder Pad:

1. Disconnect the Velcro straps located at Positions X, Y, and Z along each leg of the harness. To remove, first disconnect the Top Strap (A) and then pull away the Bottom Strap (B).
2. After this is done, the Back and Shoulder Pad may be removed from the full body harness. To reattach the Back and Shoulder Pad, simply follow the procedure in reverse.

Figure 17 - Removing the Back and Shoulder Pad

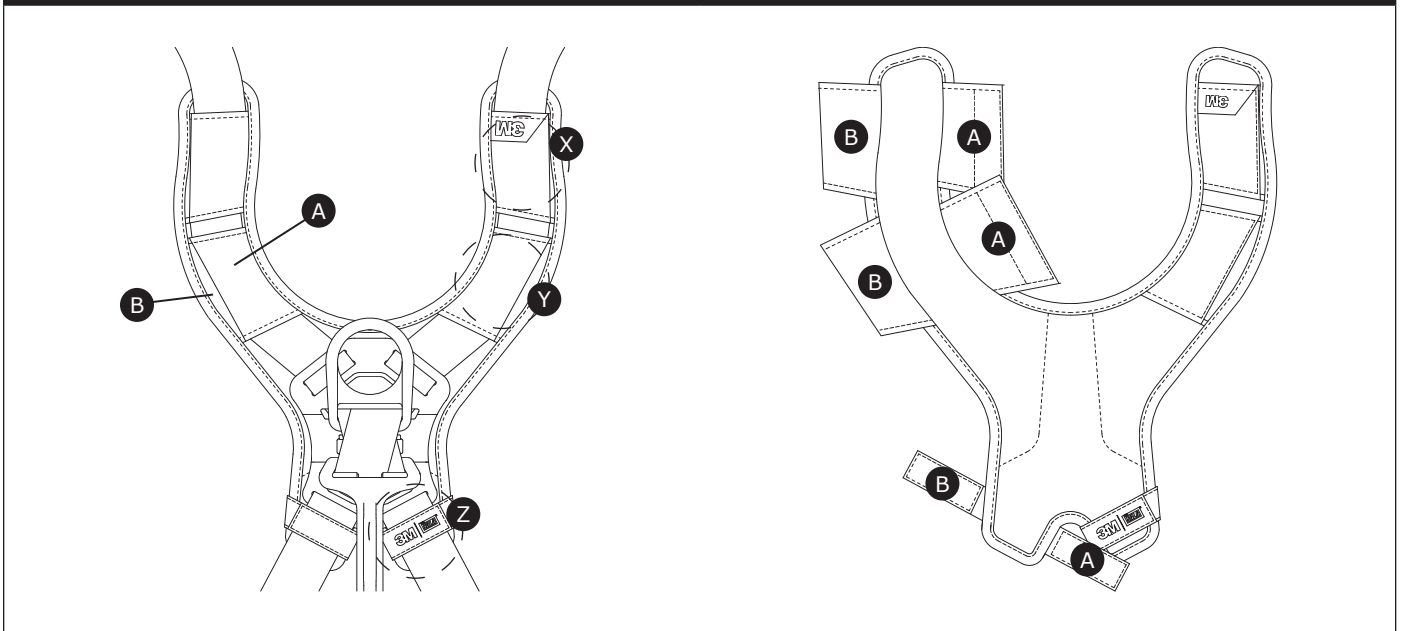

3.13 REMOVING THE LEG PADS: The Leg Pads may be removed from the Harness for cleaning or adjustment. The Leg Pads of the Harness are secured to the Harness by hook and loop straps along each leg of the Harness. See Figure 18 for reference. To remove the Leg Pads:

1. Disconnect the hook and loop straps of the Leg Pad (X). To remove, first disconnect the Top Strap (A) and then pull away the Bottom Strap (B).
2. After this is done, the Leg Pad may be removed from the Full Body Harness. Repeat these steps to remove the other Leg Pad, or follow the procedure in reverse to reattach the Leg Pad.

Figure 18 - Removing the Leg Pads

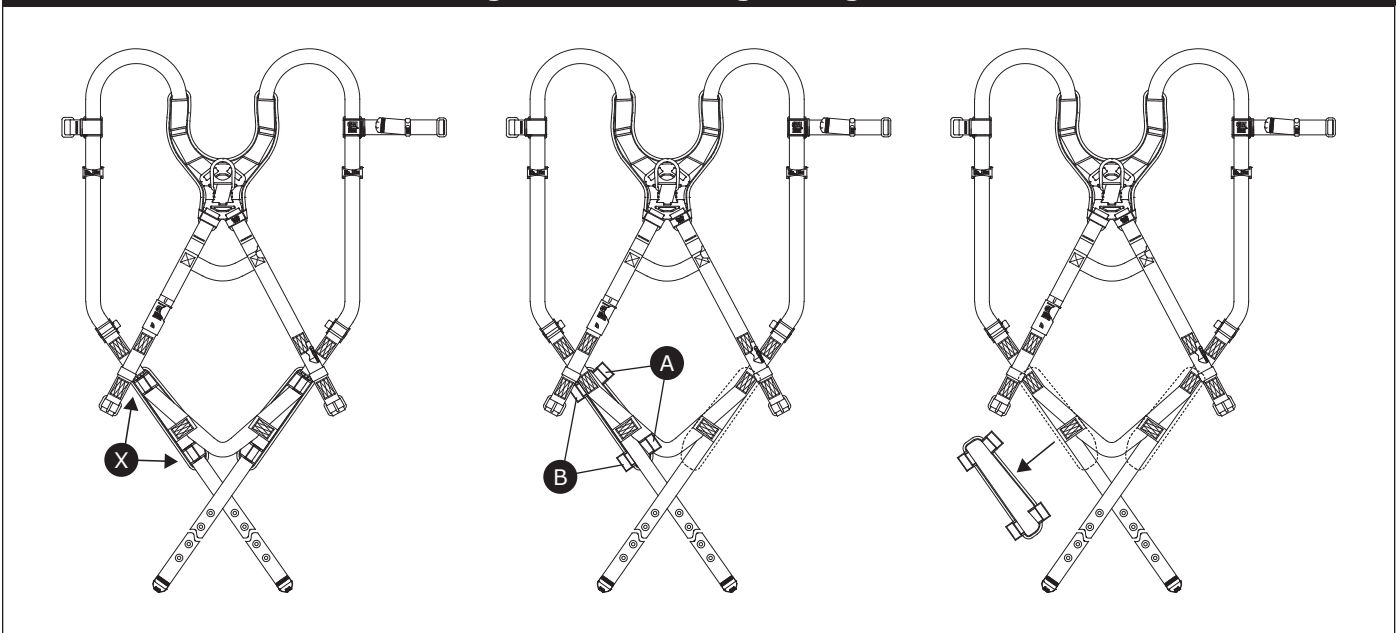

3.14 CONNECTING SYSTEM COMPONENTS: After donning the harness, the user may connect to their Fall Protection System. Observe all requirements as specified in these instructions and any manufacturer's instructions included with the system components. See the Product Overview for more information on System Applications.

4.0 USE

- 4.1 BEFORE EACH USE:** Verify that your work area and Fall Protection system meet all criteria defined in these instructions. Verify that a formal Rescue Plan is in place. Inspect the product per the points of the "Inspection and Maintenance Log". If inspection reveals an unsafe or defective condition, or if any doubt should arise about its condition for safe use, remove the product from service immediately. Clearly tag the system "DO NOT USE". See Section 5 for more information.
- 4.2 MAKING CONNECTIONS:** When using a hook to connect to an anchorage or when coupling components of the system together, ensure roll-out cannot occur. Roll-out occurs when interference between the hook and mating connector causes the hook gate to unintentionally open and release. Self-locking snap hooks and carabiners should be used to reduce the possibility of roll-out. Do not use hooks or connectors that will not completely close over the attachment object. See subsystem manufacturer's instructions for more information on making connections.

5.0 INSPECTION

After equipment has been removed from service, it may not be returned to service until a Competent Person confirms in writing that it is acceptable to do so.

- 5.1 INSPECTION FREQUENCY:** The product shall be inspected by the user before each use and, additionally, by a Competent Person other than the user at intervals of no longer than one year. A higher frequency of equipment use and harsher conditions may require increasing the frequency of Competent Person inspections. The frequency of these inspections should be determined by the Competent Person per the specific conditions of the worksite.
- 5.2 INSPECTION PROCEDURES:** Inspect this product per the procedures listed in the "Inspection and Maintenance Log". Documentation of each inspection should be maintained by the owner of this equipment. An inspection and maintenance log should be placed near the product or be otherwise easily accessible to users. It is recommended that the product is marked with the date of next or last inspection.
- 5.3 DEFECTS:** If the product cannot be returned to service because of an existing defect or unsafe condition, then the product must be either destroyed or sent to 3M for replacement.
- 5.4 PRODUCT LIFE:** The functional life of the product is determined by work conditions and maintenance. As long as the product passes inspection criteria, it may remain in service.

6.0 MAINTENANCE, SERVICE, and STORAGE

Equipment that is in need of maintenance or scheduled for maintenance should be tagged "DO NOT USE". These equipment tags should not be removed until maintenance is performed.

Do not clean or disinfect the product by any method other than described in the following cleaning instructions. Other methods may have adverse effects on the product or user.

- 6.1 CLEANING:** 3M Full Body Harnesses must be cleaned in accordance with 3M instructions. To clean the harness, wash in a mild, bleach-free detergent and then rinse. The harness should afterwards be hung to air-dry. Water used for cleaning and temperatures used to air-dry must never exceed 130°F (54.4°C). For more information, please refer to the technical bulletin on our website: <http://www.3M.com/FallProtection/WebCleaning>

For any questions about cleaning procedures, please contact 3M Technical Services.

- 6.2 SERVICE:** This equipment cannot be repaired. Upon permanent removal from service, cut the harness straps or otherwise render the harness unusable before disposing of it.
- 6.3 STORAGE AND TRANSPORT:** Store and transport the product in a cool, dry, clean environment out of direct sunlight. Avoid areas where chemical vapors may exist. Thoroughly inspect components after extended storage.

It is recommended that the user limit exposure of the product to UV light. Prolonged exposure to UV light could cause webbing material to degrade at a faster rate.

7.0 LABELS and MARKINGS

7.1 **LABELS:** Figure 20 illustrates product labels and their location on the harness. All labeling must be present and fully legible. Information on each label is as follows:

| | |
|----------|--------------------------------------------------------------------------------------------------------------------------------------------------------------------------------------------------------|
| A | 1) Warning Statement - Read all user instructions. 2) Harness Specifications 3) Warning Statement - Do not exceed system or harness capacity. |
| B | 1) Harness Capacity: 130 lb. - 310 lb. 2) Model Number 3) Manufactured (Year/Month) 4) Lot Number 5) Applicable Standards 6) Letter Code Identifier for Applicable Standards 7) User Identification |
| C | 1) Attachment Element Diagram and Descriptions 2) Serial Number 3) Inspection Log |

8.0 RFID Tag

8.1 **LOCATION:** 3M product covered in these user instructions is equipped with a Radio Frequency Identification (RFID) Tag. RFID Tags may be used in coordination with an RFID Tag Scanner for recording product inspection results. See Figure 19 for where your RFID Tag is located.

8.2 **DISPOSAL:** Prior to disposing of this product, remove the RFID Tag and dispose/recycle in accordance with local regulations. For more information, please visit our website: <http://www.3M.com/FallProtection/RFID>

9.0 GLOSSARY OF TERMS

9.1 **DEFINITIONS:** The following terms and definitions are used in these instructions.

For a comprehensive list of terms and definitions, please visit our website: www.3m.com/FallProtection/ifu-glossary

- **AUTHORIZED PERSON:** A person assigned by the employer to perform duties at a location where the person will be exposed to a fall hazard.
- **COMPETENT PERSON:** One who is capable of identifying existing and predictable hazards in the surroundings or working conditions which are unsanitary, hazardous, or dangerous to employees, and who has authorization to take prompt corrective measures to eliminate them.
- **FALL ARREST SYSTEM:** A collection of Fall Protection equipment configured to protect the user in the event of a fall.
- **QUALIFIED PERSON:** A person with a recognized degree, certificate, or professional standing, or who by extensive knowledge, training, and experience has successfully demonstrated their ability to solve or resolve problems relating to Fall Protection and Rescue systems to the extent required by applicable national, regional, and local regulations.
- **RESCUE SYSTEM:** A collection of Fall Protection equipment configured to remove a person from hazards to a safe location. No free fall is permitted.
- **RESCUER:** A person using the Rescue system to perform an assisted rescue.
- **RESTRAINT SYSTEM:** A collection of Fall Protection equipment configured to prevent the user from reaching a fall hazard. No free fall is permitted.
- **USER:** A person who performs activities while protected by a Fall Protection system.
- **WORK POSITIONING SYSTEM:** A collection of Fall Protection equipment configured to support a user at a work position. Maximum permissible free fall is 2 ft (61 cm).

Figure 19 - RFID Tag Location

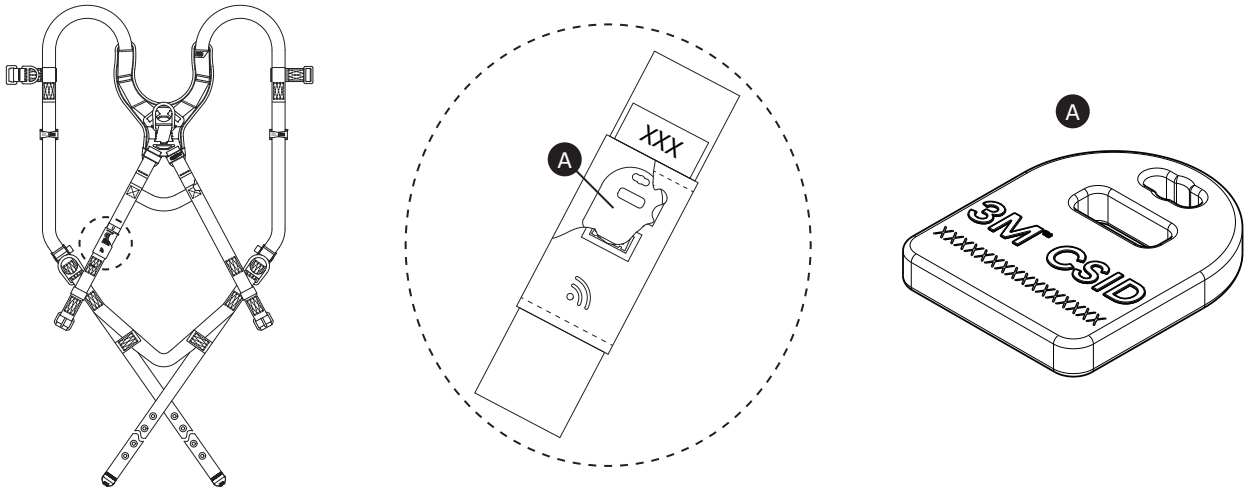
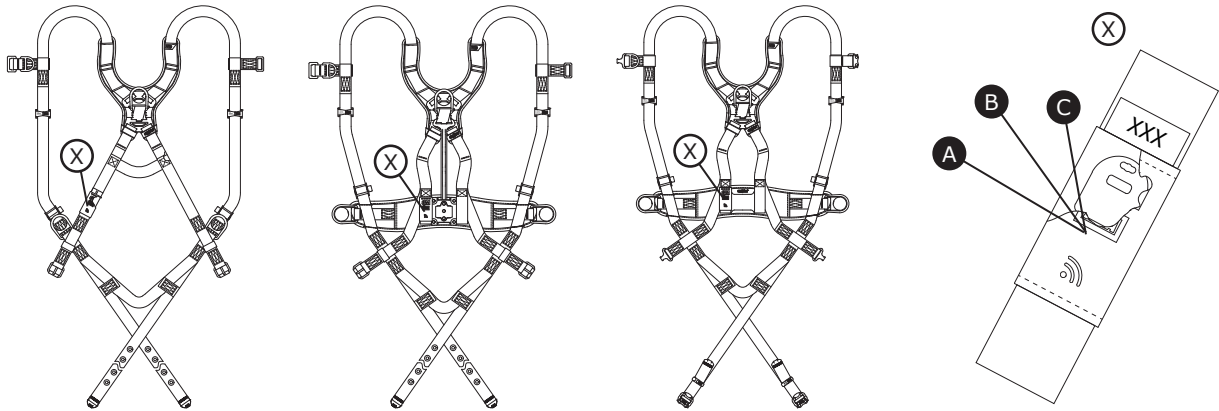

Figure 20 - Product Labels



| | | | | | | | | | | | | | | | | | | |
|---------------------------------------|-------------------------------------------------------------------------------------------------------------------------------------------------------------------------------------------------------------------------------------------------------------------------------------------------------------------------------------------------------------------------------------------------------------------------------------------------------------------------------------------------------------------------------------------------------------------------------------------------------------------------------------------------------------------------------------------------------------------------------------------------------------------------------------|------------------------------------------------------------------------------------------------------------------------------------------------------------------------------------------------------------------------------------------------------------------------------------------------------------------------------------------------------------------------------------------------------------------------------------------------------------------------------------|---------|--|--|--|--|--|--|--|------|--|--|--|--|--|--|--|
| <p>A</p> <p>9500340 Rev. K</p> | <p>1 WARNING Manufacturer's instructions must be read and understood prior to use. Instructions supplied with this product at time of shipment must be followed. Failure to do so could result in serious injury or death. Contact Capital Safety if instruction sheet is needed. Inspect before each use. Do not use if wear or damage is present. This body harness is intended to be used to arrest the most severe free falls. Items subjected to fall arrest or impact forces must be immediately removed from service and destroyed. Connecting snap and D-Ring must be compatible in size, shape, and strength. This item is not flame or heat resistant. Repairs only to be performed by Capital Safety. Equipment modification or misuse voids warranty.</p> | <p>2 Full Body Harness Material: Polyester Webbing ANSI Capacity: 130-310 lbs. OSHA Capacity: 420 lbs.</p> <p>3 WARNING Do not exceed the capacity of this or other system components. Capacity is the combined weight for which the component is designed to be used. Combined weight includes the user's body weight, clothing, tools, and any objects carried. Contact Capital Safety for more information.</p> <p>DO NOT REMOVE LABEL</p> | | | | | | | | | | | | | | | | |
| <p>B</p> <p>9500320 Rev. E</p> | <p>1 ANSI Z359.11-2014 ANSI Z359 Recognizes the use of this harness only within the capacity range of: 130-310 lbs.</p> <p>Model No.: 2 Mfrd.,(yrr/mo): 3 Lot: 4 Stds: 5</p> | <p>PRODUCT COMPLIANCE DO NOT REMOVE THIS LABEL 6</p> <p>This product complies with the following standards only if marked with the corresponding letter code under the "Stds" section. D = ASTM F887 A = ANSI Z359.1 E = ANSI Z359.3 B = OSHA F = ANSI Z359.4 C = ANSI A10.32 G = ANSI Z359.11</p> <p>USER IDENTIFICATION 7 Mark label with permanent marker _____</p> | | | | | | | | | | | | | | | | |
| <p>C</p> <p>9500011 Rev. D</p> | <p>1 A - Dorsal attachment element is for fall arrest, travel restraint, or rescue. 2 B - Sternum attachment element is for fall arrest (feet first falls only, 2 ft. maximum free fall), travel restraint, or rescue. 3 C - Frontal attachment element is for fall arrest (feet first falls only, 2 ft. maximum free fall), work positioning, travel restraint, or rescue. 4 D - Shoulder attachment elements are for rescue or entry/rescue. 5 E - Waist, rear attachment element is for travel restraint. 6 F - Hip attachment elements are for work positioning or travel restraint.</p> | <p>SERIAL NO.: SEE RFID TAG 2</p> <table border="1"> <tr> <td>INITIAL</td> <td></td> <td></td> <td></td> <td></td> <td></td> <td></td> <td></td> </tr> <tr> <td>DATE</td> <td></td> <td></td> <td></td> <td></td> <td></td> <td></td> <td></td> </tr> </table> <p>INSPECTION LOG 3</p> | INITIAL | | | | | | | | DATE | | | | | | | |
| INITIAL | | | | | | | | | | | | | | | | | | |
| DATE | | | | | | | | | | | | | | | | | | |

Table 2 – Inspection and Maintenance Log

| Model Number (Serial Number): | | | | | |
|------------------------------------------------------------------------------------------------------------------------------------------------------------------------------------------------------------------------------------------------------------------------------------|--------------------------------------------------------------------------------------------------------------------------------------------------------------------------------------------------------------------------------------------------------------------------------------------------------------------------------------------------------------------------------------------------------------------------------------------|-------------------------------------------|-----------------------------------|-------------------------------|-------------------------------|
| Date Purchased: | | | Date of First Use: | | |
| ... | | | | | |
| <input checked="" type="checkbox"/> <i>This product must be inspected by the user before each use. Additionally, a Competent Person other than the user must inspect this equipment at least once each year.</i> | | | | | |
| ... | | | | | |
| Component | Inspection Procedure | | | Inspection Result | |
| | | | | Pass | Fail |
| Harness Hardware (Table 1) | Inspect all harness hardware for damage, including all attachment elements, buckles, adjusters, and other elements. Each of these items must not be damaged, broken, or distorted. Each item must also be free of any sharp edges, burrs, cracks, worn parts, or corrosion. PVC-coated hardware must be free of cuts, rips, tears, and holes in the coating to ensure non-conductivity. Ensure all buckles and adjusters operate smoothly. | | | <input type="checkbox"/> | <input type="checkbox"/> |
| Webbing & Stitching (Figure 21) | Inspect the webbing of the harness across all areas. All webbing material must be free of cuts (A), fraying (B), heavy soiling (C), and welding burns (D). Check for tears, abrasions, mold, burns, discoloration, and broken fibers. Check for pulled or cut stitches. Broken stitches may indicate that the harness has been impact loaded and must be removed from service. | | | <input type="checkbox"/> | <input type="checkbox"/> |
| Stitched Impact Indicators (Figure 22) | Verify all Impact Indicators are intact. Impact Indicators are sections of webbing lapped back on themselves and secured with a specific stitch pattern. This stitch pattern is designed to release when the harness arrests a fall or is exposed to equivalent force. If an Impact Indicator has been activated (indicated), then the harness must be removed from service and destroyed. | | | <input type="checkbox"/> | <input type="checkbox"/> |
| Labels (Figure 20) | All labels are present and fully legible. | | | <input type="checkbox"/> | <input type="checkbox"/> |
| Fall Protection Equipment | Additional Fall Protection equipment that is used with the product is installed and inspected per the manufacturer instructions. | | | <input type="checkbox"/> | <input type="checkbox"/> |
| ... | | | | | |
| <input checked="" type="checkbox"/> <i>If the product fails an inspection procedure, then the product fails overall inspection. If the product fails inspection, remove it from service immediately. Clearly tag the product "DO NOT USE". See Section 5 for more information.</i> | | | | | |
| ... | | | | | |
| Inspection Type: | <input type="checkbox"/> User | <input type="checkbox"/> Competent Person | Overall Inspection Result: | <input type="checkbox"/> Pass | <input type="checkbox"/> Fail |
| Inspected By: | | | Date of Inspection: | | |
| Signature: | | | Next Inspection Due: | | |
| ... | | | | | |
| Additional Notes: | | | | | |

Figure 21 - Webbing

Figure 22 - Impact Indicators

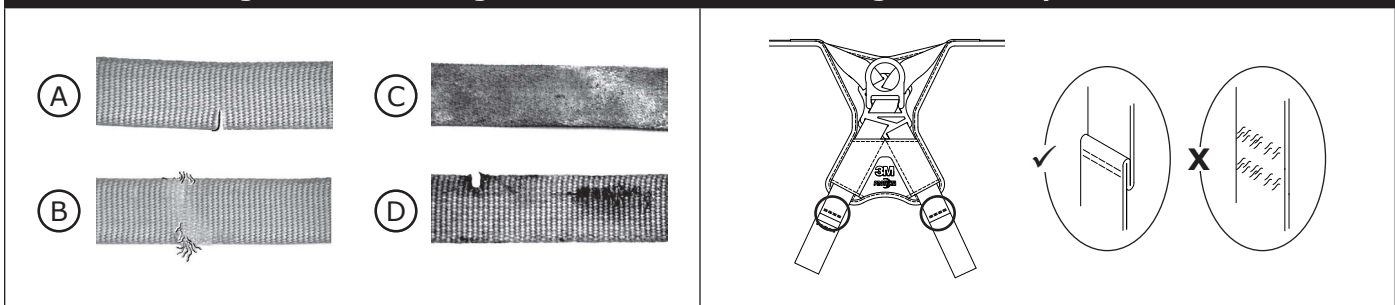

① **NOTE:** *These are general requirements and information provided by ANSI/ASSP Z359. 3M Fall Protection may impose more stringent restrictions on the use of its products; refer to your 3M instruction manual for more information.*

1. It is essential that the users of this type of equipment receive proper training and instruction, including detailed procedures for the safe use of such equipment in their work application. ANSI/ASSP Z359.2, "Minimum Requirements for a Comprehensive Managed Fall Protection Program", establishes guidelines and requirements for an employer's managed Fall Protection program, including policies, duties and training; Fall Protection procedures; eliminating and controlling fall hazards; rescue procedures; incident investigations; and evaluating program effectiveness.
2. Correct fit of a Full Body Harness (FBH) is essential to proper performance. Users must be trained to select the size and maintain the fit of their Full Body Harness.
3. Users must follow manufacturer's instructions for proper fit and sizing, paying particular attention to ensure that buckles are connected and aligned correctly, leg straps and shoulder straps are kept snug at all times, chest straps are located in the middle chest area, and leg straps are positioned and snug to avoid contact with the genitalia should a fall occur.
4. Full Body Harnesses which meet ANSI/ASSP Z359.11 are intended to be used with other components of a Personal Fall Arrest System that limit maximum arrest forces to 1800 lbf (8 kN) or less.
5. Suspension intolerance, also called suspension trauma or orthostatic intolerance, is a serious condition that can be controlled with good harness design, prompt rescue and post-fall suspension relief devices. A conscious user may deploy a suspension relief device allowing the user to remove tension from around the legs, freeing blood flow, which can delay the onset of suspension intolerance. An attachment element extender is not intended to be attached directly to an anchorage or anchorage connector for fall arrest. An energy absorber must be used to limit maximum arrest forces to 1800 lbf (8 kN). The length of the attachment element extender may affect free fall distances and free fall clearance calculations.
6. Full Body Harness (FBH) Stretch, the amount the FBH component of a Personal Fall Arrest System will stretch and deform during a fall, can contribute to the overall elongation of the system in stopping a fall. It is important to include the increase in fall distance created by FBH Stretch, as well as the FBH connector length, the settling of the user's body in the FBH, and all other contributing factors when calculating total clearance required for a particular Fall Arrest system.
7. When not in use, unused lanyard legs that are still attached to a Full Body Harness D-Ring should not be attached to a Work Positioning element or any other structural element on the Full Body Harness unless deemed acceptable by the Competent Person and manufacturer of the lanyard. This is especially important when using some types of "Y" style lanyards, as some load may be transmitted to the user through the unused lanyard leg if it is not able to release from the harness. The lanyard parking attachment is generally located in the sternal area to help reduce tripping and entanglement hazards.
8. Loose ends of straps can get caught in machinery or cause accidental disengagement of an adjuster. All Full Body Harnesses shall include keepers or other components which serve to control the loose ends of straps.
9. Due to the nature of soft loop connections, it is recommended that soft loop attachments only be used to connect with other soft loops or carabiners. Snap Hooks should not be used unless approved for the application by the manufacturer.

Sections 10-16 provide additional information concerning the location and use of various attachments that may be provided on this Full Body Harness (FBH).

- 10. Dorsal** – The dorsal attachment element shall be used as the primary Fall Arrest attachment, unless the application allows the use of an alternate attachment. The dorsal attachment may also be used for Travel Restraint or Rescue. When supported by the dorsal attachment during a fall, the design of the Full Body Harness shall direct load through the shoulder straps supporting the user, and around the thighs. Supporting the user post-fall by the dorsal attachment will result in an upright body position with a slight lean to the front with some slight pressure to the lower chest. Considerations should be made when choosing a sliding versus fixed dorsal attachment element. Sliding dorsal attachments are generally easier to adjust to different user sizes, and allow a more vertical rest position post-fall, but can increase FBH Stretch.
- 11. Sternal** – The sternal attachment may be used as an alternative Fall Arrest attachment in applications where the dorsal attachment is determined to be inappropriate by a Competent Person, and where there is no chance to fall in a direction other than feet first. Accepted practical uses for a sternal attachment include, but are not limited to, ladder climbing with a guided-type fall arrester, ladder climbing with an overhead self-retracting lifeline for fall arrest, Work Positioning, and rope access. The sternal attachment may also be used for Travel Restraint or Rescue.

When supported by the sternal attachment during a fall, the design of the Full Body Harness shall direct load through the shoulder straps supporting the user, and around the thighs. Supporting the user post-fall by the sternal attachment will result in roughly a sitting or cradled body position with weight concentrated on the thighs, buttocks and lower back. Supporting the user during Work Positioning by this sternal attachment will result in an approximate upright body position.

If the sternal attachment is used for Fall Arrest, the Competent Person evaluating the application should take measures to ensure that a fall can only occur feet first. This may include limiting the allowable free fall distance. It may be possible for a sternal attachment incorporated into an adjustable style chest strap to cause the chest strap to slide up and possibly choke the user during a fall, extraction, suspension, etc. The Competent Person should consider Full Body Harness models with a fixed sternal attachment for these applications.

- 12. Frontal** – The frontal attachment serves as a ladder climbing connection for guided-type fall arresters where there is no chance to fall in a direction other than feet first, or may be used for Work Positioning. Supporting the user, post-fall or during work positioning, by the frontal attachment will result in a sitting body position, with the upper torso upright, with weight concentrated on the thighs and buttocks. When supported by the frontal attachment the design of the Full Body Harness shall direct load directly around the thighs and under the buttocks by means of the sub-pelvic strap.
- If the frontal attachment is used for Fall Arrest, the Competent Person evaluating the application should take measures to ensure that a fall can only occur feet first. This may include limiting the allowable free fall distance.
- 13. Shoulder** – The shoulder attachment elements shall be used as a pair, and are an acceptable attachment for Rescue and Entry/Retrieval. The shoulder attachment elements shall not be used for Fall Arrest. It is recommended that the shoulder attachment elements be used in conjunction with a yoke which incorporates a spreader element to keep the Full Body Harness shoulder straps separate.
- 14. Waist, Rear** – The waist, rear attachment shall be used solely for Travel Restraint. The waist, rear attachment element shall not be used for Fall Arrest. Under no circumstances is it acceptable to use the waist, rear attachment for purposes other than Travel Restraint. The waist, rear attachment shall only be subjected to minimal loading through the waist of the user, and shall never be used to support the full weight of the user.
- 15. Hip** – The hip attachment elements shall be used as a pair, and shall be used solely for Work Positioning. The hip attachment elements shall not be used for fall arrest. Hip attachments are often used for Work Positioning by arborists, utility workers climbing poles, and construction workers tying rebar and climbing on form walls. Users are cautioned against using the hip attachment elements (or any other rigid point on the Full Body Harness) to store the unused end of a Fall Arrest lanyard, as this may cause a tripping hazard, or, in the case multiple leg lanyards, could cause adverse loading to the Full Body Harness and the wearer through the unused portion of the lanyard.
- 16. Suspension Seat** – The suspension seat attachment elements shall be used as a pair, and shall be used solely for Work Positioning. The suspension seat attachment elements shall not be used for Fall Arrest. Suspension seat attachments are often used for prolonged work activities where the user is suspended, allowing the user to sit on the suspension seat formed between the two attachment elements. An example of this use would be window washers on large buildings.

User Inspection, Maintenance, and Storage of Equipment

Users of Personal Fall Arrest Systems shall, at a minimum, comply with all manufacturer instructions regarding the inspection, maintenance and storage of the equipment. The user's organization shall retain the manufacturer's instructions and make them readily available to all users. See ANSI/ASSP Z359.2, "Minimum Requirements for a Comprehensive Managed Fall Protection Program", regarding user inspection, maintenance, and storage of equipment.

1. In addition to the inspection requirements set forth in the manufacturer's instructions, the equipment shall be inspected by the user before each use and, additionally, by a Competent Person, other than the user, at intervals of no more than one year for:
 - Absence or illegibility of markings.
 - Absence of any elements affecting the equipment form, fit or function.
 - Evidence of defects in, or damage to, hardware elements including cracks, sharp edges, deformation, corrosion, chemical attack, excessive heating, alteration and excessive wear.
 - Evidence of defects in or damage to strap or ropes including fraying, unsplicing, unlaying, kinking, knotting, roping, broken or pulled stitches, excessive elongation, chemical attack, excessive soiling, abrasion, alteration, needed or excessive lubrication, excessive aging and excessive wear.
2. Inspection criteria for the equipment shall be set by the user's organization. Such criteria for the equipment shall equal or exceed the criteria established by this standard or the manufacturer's instructions, whichever is greater.
3. When inspection reveals defects in, damage to, or inadequate maintenance of equipment, the equipment shall be permanently removed from service or undergo adequate corrective maintenance, by the original equipment manufacturer or their designate, before return to service.

Maintenance and Storage

1. Maintenance and storage of equipment shall be conducted by the user's organization in accordance with the manufacturer's instructions. Unique issues, which may arise due to conditions of use, shall be addressed with the manufacturer.
2. Equipment which is in need of, or scheduled for, maintenance shall be tagged as unusable and removed from service.
3. Equipment shall be stored in a manner as to preclude damage from environmental factors such as temperature, light, UV, excessive moisture, oil, chemicals and their vapors, or other degrading elements.

GLOBAL PRODUCT WARRANTY, LIMITED REMEDY AND LIMITATION OF LIABILITY

WARRANTY: THE FOLLOWING IS MADE IN LIEU OF ALL WARRANTIES OR CONDITIONS, EXPRESS OR IMPLIED, INCLUDING THE IMPLIED WARRANTIES OR CONDITIONS OF MERCHANTABILITY OR FITNESS FOR A PARTICULAR PURPOSE.

Unless otherwise provided by local laws, 3M fall protection products are warranted against factory defects in workmanship and materials for a period of one year from the date of installation or first use by the original owner.

LIMITED REMEDY: Upon written notice to 3M, 3M will repair or replace any product determined by 3M to have a factory defect in workmanship or materials. 3M reserves the right to require product be returned to its facility for evaluation of warranty claims. This warranty does not cover product damage due to wear, abuse, misuse, damage in transit, failure to maintain the product or other damage beyond 3M's control. 3M will be the sole judge of product condition and warranty options.

This warranty applies only to the original purchaser and is the only warranty applicable to 3M's fall protection products. Please contact 3M's customer service department in your region for assistance.

LIMITATION OF LIABILITY: TO THE EXTENT PERMITTED BY LOCAL LAWS, 3M IS NOT LIABLE FOR ANY INDIRECT, INCIDENTAL, SPECIAL OR CONSEQUENTIAL DAMAGES INCLUDING, BUT NOT LIMITED TO LOSS OF PROFITS, IN ANY WAY RELATED TO THE PRODUCTS REGARDLESS OF THE LEGAL THEORY ASSERTED.



Fall Protection

USA

3833 SALA Way
Red Wing, MN 55066-5005
Toll Free: 800.328.6146
Phone: 651.388.8282
Fax: 651.388.5065
3Mfallprotection@mmm.com

Brazil

Rodovia Anhanguera, km 110
Sumaré - SP
CEP: 13181-900
Brasil
Phone: 0800-013-2333
falecoma3m@mmm.com

Mexico

Av. Santa Fe No. 190
Col. Santa Fe, Ciudad de Mexico
CP 01219, Mexico
Phone: 01 800 120 3636
3msaludocupacional@mmm.com

Canada

600 Edwards Blvd, Unit #2
Mississauga, ON L5T 2V7
Phone: 905.795.9333
Toll-Free: 800.387.7484
Fax: 888.387.7484
3Mfallprotection-ca@mmm.com

EMEA (Europe, Middle East, Africa)

EMEA Headquarters:
Le Broc Center
Z.I. 1re Avenue - BP15
06511 Carros Le Broc Cedex
France
Phone: + 33 04 97 10 00 10
Fax: + 33 04 93 08 79 70
informationfallprotection@mmm.com

Australia & New Zealand

137 McCredie Road
Guildford
Sydney, NSW, 2161
Australia
Toll-Free : 1800 245 002 (AUS)
Toll-Free : 0800 212 505 (NZ)
3msafetyau@mmm.com

Asia

Singapore:
1 Yishun Avenue 7
Singapore 768923
Phone: +65-6450 8888
Fax: +65-6552 2113
TotalFallProtection@mmm.com

China:

38/F, Maxdo Center, 8 Xing Yi Rd
Shanghai 200336, P R China
Phone: +86 21 62753535
Fax: +86 21 52906521
3MFallProtection-CN@mmm.com

Korea:

3M Korea Ltd
20F, 82, Uisadang-daero,
Yeongdeungpo-gu, Seoul
Phone: +82-80-033-4114
Fax: +82-2-3771-4271
TotalFallProtection@mmm.com

Japan:

3M Japan Ltd
6-7-29, Kitashinagawa, Shinagawa-ku, Tokyo
Phone: +81-570-011-321
Fax: +81-3-6409-5818
psd.jp@mmm.com

WEBSITE:
3M.com/FallProtection



EU DECLARATION OF CONFORMITY:
3M.com/FallProtection/DOC