



Main

Range of Product	Modicon X80
Product or Component Type	Encoder interface module
Function Available	Offset Compare Modulo Reduction Capture
Number of channels	3 SSI channel
Number of outputs	1 24 V DC reflex digital output for each SSI channel
Number of inputs	2 24 V DC capture digital inputs for the 3 SSI channels

Complementary

Data format	8...31 bits
Transmission Rate	500 kbauds 200 kbauds 1 Mbauds 100 kbauds
Refresh time	1 ms
Input compatibility	24 V DC SSI absolute encoder 19.2...30 V)200 mA per channel
Dielectric strength	1400 V DC 60 s
[Us] rated supply voltage	19.2...30 V DC, <30 mA 24 V DC, <30 mA typical)
Protection type	Overvoltage protection DC
Current consumption	150 mA 3.3 V DC back plane, (typical) 250 mA 3.3 V DC back plane, (maximum)
Net Weight	0.30 lb(US) (0.138 kg)

Environment

Ambient Air Temperature for Operation	32...140 °F (0...60 °C)
Operating altitude	0...13123.36 ft (0...4000 m)
IP Degree of Protection	IP20
Directives	2014/35/EU - low voltage directive 2014/30/EU - electromagnetic compatibility
Product certifications	CE[RETURN]RCM[RETURN]CSA[RETURN]EAC[RETURN]Merchant Navy[RETURN]UL
Standards	EN/IEC 61010-2-201 EN/IEC 61131-2 UL 61010-2-201 CSA C22.2 No 61010-2-201

Ordering and shipping details

Category	18160-MODICON M340
Discount Schedule	PC34
GTIN	3595864126685
Returnability	No
Country of origin	FR

Packing Units

Unit Type of Package 1	PCE
Number of Units in Package 1	1
Package 1 Height	2.17 in (5.500 cm)
Package 1 Width	4.33 in (11.000 cm)
Package 1 Length	4.53 in (11.500 cm)
Package 1 Weight	5.89 oz (167.000 g)
Unit Type of Package 2	S02
Number of Units in Package 2	15
Package 2 Height	5.91 in (15.000 cm)
Package 2 Width	11.81 in (30.000 cm)
Package 2 Length	15.75 in (40.000 cm)
Package 2 Weight	6.17 lb(US) (2.800 kg)

Offer Sustainability

California proposition 65	WARNING: This product can expose you to chemicals including: Lead and lead compounds, which is known to the State of California to cause cancer and birth defects or other reproductive harm. For more information go to www.P65Warnings.ca.gov
REACH Regulation	REACH Declaration
EU RoHS Directive	Pro-active compliance (Product out of EU RoHS legal scope)
Mercury free	Yes
China RoHS Regulation	China RoHS Declaration
RoHS exemption information	Yes
WEEE	The product must be disposed on European Union markets following specific waste collection and never end up in rubbish bins.

Contractual warranty

Warranty	18 months
----------	-----------

Modules Mounted on Racks

Dimensions

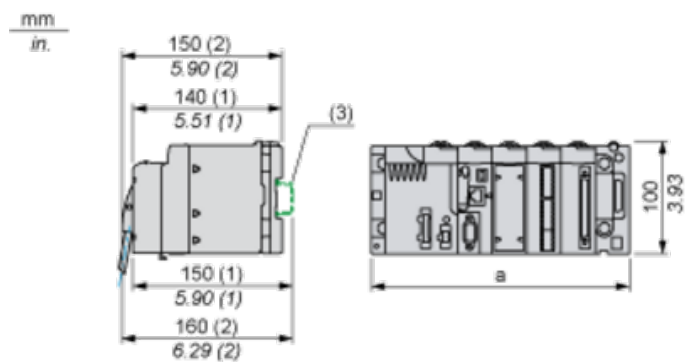

(1) With removable terminal block (cage, screw or spring).

(2) With FCN connector.

(3) On AM1 ED rail: 35 mm wide, 15 mm deep. Only possible with BMXXBP0400/0400H/0600/0600H/0800/0800H rack.

Rack references	a in mm	a in in.
BMXXBP0400 and BMXXBP0400H	242.4	09.54
BMXXBP0600 and BMXXBP0600H	307.6	12.11
BMXXBP0800 and BMXXBP0800H	372.8	14.68
BMXXBP1200 and BMXXBP1200H	503.2	19.81

Wiring Diagram

