

Main

Range of product	Lexium integrated drive
Product or component type	Motion integrated drive
Device short name	ILA
Motor type	Ac synchronous servo motor
Number of motor poles	6
Phase	Single phase
[Us] rated supply voltage	48 V 24 V
Network type	DC
Communication interface	Modbus TCP, Integrated
Length	7.45 in (189.3 mm)
Winding type	Medium speed of rotation and medium torque
Electrical connection	Printed circuit board connector
Holding brake	Without
Gear box type	Without
Nominal speed	3200 rpm 24 V 5100 rpm 48 V
Nominal torque	3.89 lbf.in (0.44 N.m)

Complementary

Transmission rate	10, 100 Mbits
Mounting support	Flange
Motor flange size	2.24 in (57 mm)
Number of motor stacks	1
Centring collar diameter	1.97 in (50 mm)
Centring collar depth	0.06 in (1.6 mm)
Number of mounting holes	4
Mounting holes diameter	0.20 in (5.2 mm)
Circle diameter of the mounting holes	2.62 in (66.6 mm)
Feedback type	Multi turn encoder
Shaft end	Untapped
Second shaft	Without second shaft end
Shaft diameter	0.35 in (9 mm)
Shaft length	0.79 in (20 mm)
Supply voltage limits	18...55.2 V
Current consumption	5000 mA maximum continuous 7000 mA peak
Associated fuse rating	16 A
Commissioning interface	RS485 Modbus TCP 9.6, 19.2 and 38.4 kbauds)
Input/output type	4 signals (each be used as input or output)
Voltage state 0 guaranteed	-3...4.5 V
Voltage state 1 guaranteed	15...30 V
Discrete input current	10 MA at 24 V safety input 2 mA at 24 V 24 V signal interface
Discrete output voltage	23...25 V
Maximum switching current	100 MA per output 200 mA total

Protection type	Safe torque off Overload of output voltage Short circuit of the output voltage
Peak stall torque	5.49 lbf.in (0.62 N.m)
Continuous stall torque	3.89 lbf.in (0.44 N.m)
Speed feedback resolution	16384 points/turn x 4096 turns
Accuracy error	+/- 0.05 °
Rotor inertia	0.095 kg.cm ²
Maximum radial force Fr	89 N
Maximum axial force Fa	104 N force pressure) 104 N tensile force)
Service life in hours	20000 h bearing
Marking	CE
Type of cooling	Natural convection
Net weight	3.09 lb(US) (1.4 kg)

Environment

Standards	EN 61800-3 : 2001-02 EN/IEC 61800-3 EN 50347 IEC 60072-1 IEC 61800-3, Ed 2 EN 61800-3:2001, second environment EN/IEC 50178
Product certifications	TÜV CUL UL
Ambient air temperature for operation	104...131 °F (40...55 °C) with power derating of 2 % per °C) 32...104 °F (0...40 °C) without derating)
Permissible ambient air temperature around the device	221 °F (105 °C) power amplifier 230 °F (110 °C) motor
Ambient air temperature for storage	-13...158 °F (-25...70 °C)
Operating altitude	<= 1000 m without derating
Relative humidity	15...85 % without condensation
Vibration resistance	20 m/s ² 10...500 Hz) 10 cycles EN/IEC 60068-2-6
Shock resistance	150 m/s ² 1000 shocks EN/IEC 60068-2-29
IP degree of protection	IP41 shaft bushing: conforming to EN/IEC 60034-5 Total except shaft bushing IP54 EN/IEC 60034-5

Ordering and shipping details

Category	18288 - LEXIUM INTEGRATED DRIVES II
Discount Schedule	PC56
GTIN	03606485187846
Nbr. of units in pkg.	1
Package weight(Lbs)	3.74 lb(US) (1.70 kg)
Returnability	No
Country of origin	DE

Packing Units

Unit Type of Package 1	PCE
Package 1 Height	3.15 in (8 cm)
Package 1 width	7.28 in (18.5 cm)
Package 1 Length	13.98 in (35.5 cm)

Contractual warranty

Warranty	18 months
----------	-----------

Integrated Drive without Holding Brake

Dimensions

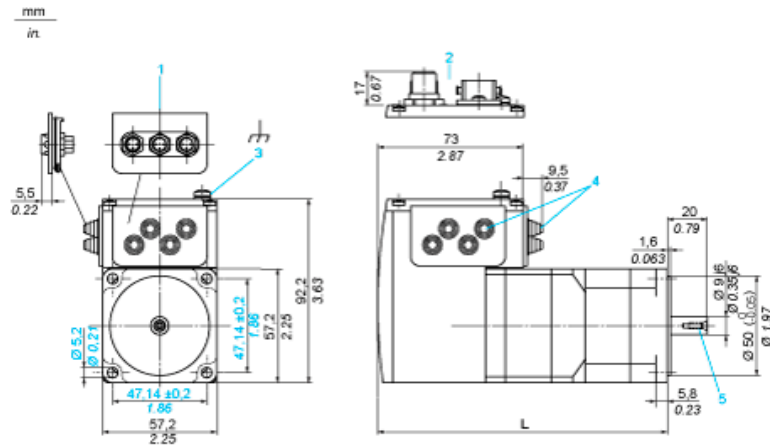

- 1 Accessories: I/O signal insert with industrial connectors
 - 2 Option: industrial connectors
 - 3 Earth (ground) terminal
 - 4 Accessories: cable entries $\varnothing = 3 \dots 9$ mm/0.12 ... 0.35 in.
 - 5 Centring hole DIN 332 - DS M3
- L : 178.8 mm/7.04 in.

Connection Example with 4 I/O Signals



Torque Characteristics

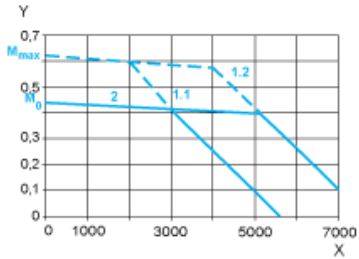

- X Speed of rotation in rpm
- Y Torque in Nm
- 1.1 Max. torque at 24 V
- 1.2 Max. torque at 48 V
- 2 Continuous torque