

Product data sheet

Characteristics

VW3A31812

kit for UL type 1 conformity - mounted under variable speed drive

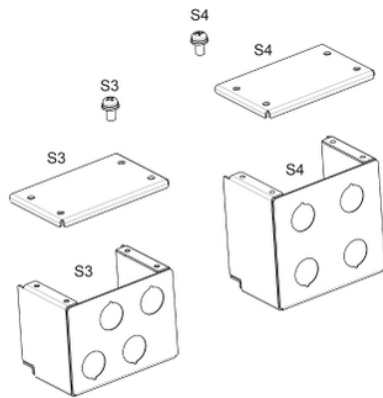

Main

Range of Product	Altivar
Accessory / separate part category	Connection accessories
Accessory / separate part type	Kit for UL type 1 conformity
Product compatibility	ATV312H018M2 ATV312H037M2 ATV312H055M2 ATV312H075M2
Accessory / separate part destination	Ensuring UL type 1 conformity to Altivar 31 drive

Complementary

Range Compatibility	Altivar 312 Altivar 312 Solar
Kit composition	Mechanical device
Mounting Location	Underside of drive
Net Weight	0.88 lb(US) (0.4 kg)

Environment

Standards	UL Type 1
-----------	-----------

Ordering and shipping details

Category	22154-ATV320/ATV312/ATV32 ACCESSORIES
Discount Schedule	CP4B
GTIN	3389110690828
Returnability	No
Country of origin	FR

Packing Units

Unit Type of Package 1	PCE
Number of Units in Package 1	1
Package 1 Height	3.20 in (8.128 cm)
Package 1 Width	6.80 in (17.272 cm)
Package 1 Length	9.50 in (24.13 cm)
Package 1 Weight	16.32 oz (462.669 g)

The information provided in this documentation contains general descriptions and/or technical characteristics of the performance of the products contained herein. This documentation is not intended as a substitute for and is not to be used for determining suitability or reliability of these products for specific user applications. It is the duty of any such user or integrator to perform the appropriate and complete risk analysis, evaluation and testing of the products with respect to the relevant specific application or use thereof. Neither Schneider Electric Industries SAS nor any of its affiliates or subsidiaries shall be responsible or liable for misuse of the information contained herein.

Offer Sustainability

California proposition 65	WARNING: This product can expose you to chemicals including: Lead and lead compounds, which is known to the State of California to cause cancer and birth defects or other reproductive harm. For more information go to www.P65Warnings.ca.gov
REACH free of SVHC	Yes
EU RoHS Directive	Pro-active compliance (Product out of EU RoHS legal scope) EU RoHS Declaration
Mercury free	Yes
China RoHS Regulation	China RoHS Declaration
RoHS exemption information	Yes

Contractual warranty

Warranty	18 months
----------	-----------