



Main

Range compatibility	Lexium SD3
Product or component type	Motion control motor
Device short name	BRS3
Maximum mechanical speed	3000 rpm
Motor type	3-phase stepper motor
Number of motor poles	6
Supply voltage limits	230 V AC 325 V DC
Mounting support	Flange
Motor flange size	3.35 in (85 mm)
Length	6.18 in (157 mm)
Centring collar diameter	2.36 in (60 mm)

Complementary

Centring collar depth	0.08 in (2 mm)
Number of mounting holes	4
Mounting holes diameter	0.26 in (6.5 mm)
Circle diameter of the mounting holes	3.90 in (98.99 mm)
Electrical connection	Connector
Feedback type	Single turn encoder
Speed feedback resolution	10000 points/turn
Holding brake	With
Shaft end	Woodruff key
Second shaft	Without second shaft end
Shaft diameter	0.47 in (12 mm)
Shaft length	1.18 in (30 mm)
Nominal torque	17.70 lbf.in (2 N.m)
Peak stall torque	16.82 lbf.in (1.9 N.m)
Continuous stall torque	16.82 lbf.in (1.9 N.m)
Holding torque	20.00 lbf.in (2.26 N.m)
Rotor inertia	1.1 kg.cm ²
Resolution	1000 points/turn 1.8 °, 0.9 °, 0.72 °, 0.36 °, 0.18 °, 0.09 °, 0.072 °, 0.036 ° step angle 200, 400, 500, 1000, 2000, 4000, 5000, 10000 steps number of full steps per revolution
Accuracy error	+/- 6 arc min
Maximum starting frequency	5.3 kHz
Line Rated Current	1.75 A
Resistance	6.5 Ohm winding)
Time constant	7 ms
Maximum radial force Fr	100 N (first shaft end) 50 N second shaft end)
Maximum axial force Fa	175 N tensile force) 30 N force pressure)
Service life in hours	20000 h bearing)
Angular acceleration	200000 rad/s ²
Net weight	4.63 lb(US) (2.1 kg)

The information provided in this documentation contains general descriptions and/or technical characteristics of the performance of the products contained herein. This documentation is not intended as a substitute for and is not to be used for determining suitability or reliability of these products for specific user applications. It is the duty of any such user or integrator to perform the appropriate and complete risk analysis, evaluation and testing of the products with respect to the relevant specific application or use thereof. Neither Schneider Electric Industries SAS nor any of its affiliates or subsidiaries shall be responsible or liable for misuse of the information contained herein.

Environment

Standards	IEC 60072-1 EN 50347
Type of cooling	Natural convection
Ambient air temperature for operation	-13...104 °F (-25...40 °C)
Ambient air temperature for storage	-13...158 °F (-25...70 °C)
Operating altitude	<= 3280.84 ft (1000 m) without power derating
Relative humidity	15...85 % without condensation
Vibration resistance	20 m/s ² maximum A EN/IEC 60034-14
IP degree of protection	Shaft bushing IP41 EN/IEC 60034-5 Total except shaft bushing IP56 EN/IEC 60034-5
Temperature class	F winding IEC/EN 60034-1

Ordering and shipping details

Category	18284 - STEPPER MOTORS
Discount Schedule	PC55
GTIN	03389119223799
Nbr. of units in pkg.	1
Package weight(Lbs)	5.94 lb(US) (2.69 kg)
Returnability	No
Country of origin	DE

Packing Units

Package 1 Height	1.300 dm
Package 1 width	1.900 dm
Package 1 Length	3.950 dm

Offer Sustainability

Sustainable offer status	Green Premium product
California proposition 65	WARNING: This product can expose you to chemicals including: Lead and lead compounds, which is known to the State of California to cause cancer and birth defects or other reproductive harm. For more information go to www.P65Warnings.ca.gov
REACH Regulation	REACH Declaration
EU RoHS Directive	Pro-active compliance (Product out of EU RoHS legal scope) EU RoHS Declaration
Mercury free	Yes
RoHS exemption information	Yes
China RoHS Regulation	China RoHS Declaration
Environmental Disclosure	Product Environmental Profile
WEEE	The product must be disposed on European Union markets following specific waste collection and never end up in rubbish bins.
PVC free	Yes

Contractual warranty

Warranty	18 months
----------	-----------

Dimensions

3-Phase Stepper Motor in Connector Version

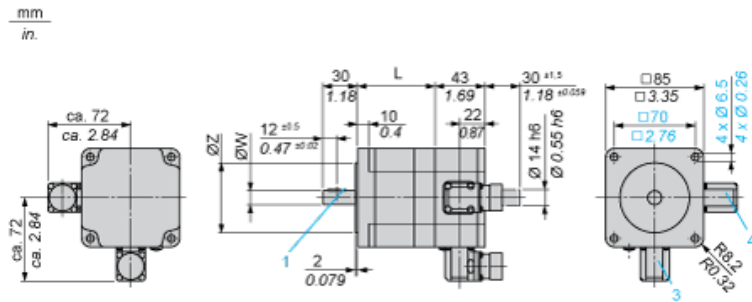

- 3 : Motor connection 6 poles
- 4 : Motor connection (optional) 12 poles

Holding Brake

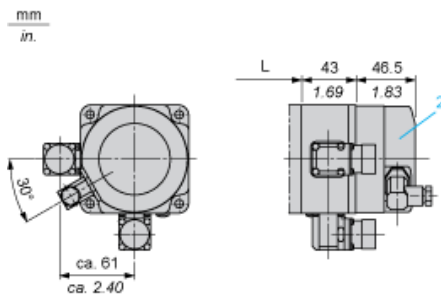

- 2 : Holding brake (optional)

Dimensions in mm

L	Shaft diameter ØW	Centring collar ØZ	Woodruff key DIN 6888 (1)
67.5 (+0.6) (-0.8)	12 h6	60 h8	4 x 6.5

Dimensions in in.

L	Shaft diameter ØW	Centring collar ØZ	Woodruff key DIN 6888 (1)
2.66 (+0.023) (-0.031)	0.47 h6	2.36 h8	0.16 x 0.25

Wiring Diagram of Holding Brake

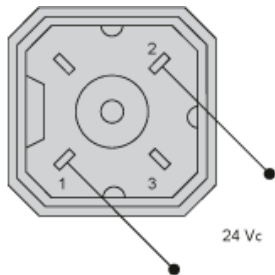

The connector is part of the scope of delivery. Connector designation: Hirschmann type G4 A 5M

Wiring Diagram of Encoder Plug on BRS3••

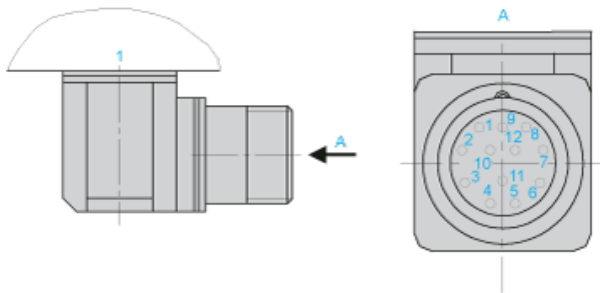

1 : Motor housing

Pin	Designation
1	A
2	A negated
3	B
4	B negated
5	C, I
6	C negated, I negated
7	5 V _{GND}
8	+ 5
9	-SENSE
10	+SENSE
11	Temperature sensor
12	Not connected

Torque Characteristics

Measurement at 1000 Steps/Revolution, Nominal Voltage DC Bus U_N and Phase Current I_N

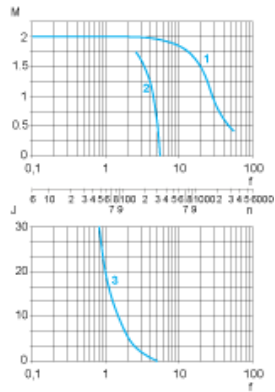

- M : Torque in Nm
- n : Speed in rpm
- f : Frequency in kHz
- J : Rotor inertia in $\text{kg}\cdot\text{cm}^2$
- 1 : Pull-out torque
- 2 : Pull-in torque
- 3 : Maximum load inertia