

BRS39AWB60FCA

3-phase stepper motor - 4.52 Nm - shaft Ø 12 mm - L=98 mm - with brake - conn

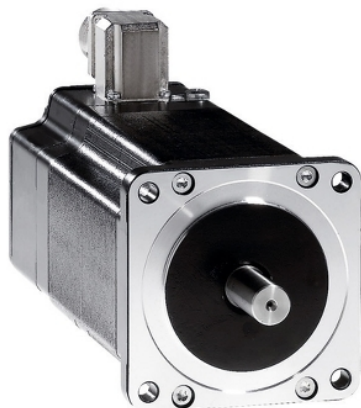

Main

Range compatibility	Lexium SD3
Product or component type	Motion control motor
Device short name	BRS3
Maximum mechanical speed	3000 rpm
Motor type	3-phase stepper motor
Number of motor poles	6
Supply voltage limits	230 V AC 325 V DC
Mounting support	Flange
Motor flange size	3.35 in (85 mm)
Length	5.55 in (141 mm)
Centring collar diameter	2.36 in (60 mm)

Complementary

Centring collar depth	0.08 in (2 mm)
Number of mounting holes	4
Mounting holes diameter	0.26 in (6.5 mm)
Circle diameter of the mounting holes	3.90 in (98.99 mm)
Electrical connection	Connector
Holding brake	With
Shaft end	Untapped
Second shaft	Without second shaft end
Shaft diameter	0.47 in (12 mm)
Shaft length	1.18 in (30 mm)
Nominal torque	35.40 lbf.in (4 N.m)
Peak stall torque	33.81 lbf.in (3.82 N.m)
Continuous stall torque	33.81 lbf.in (3.82 N.m)
Holding torque	40.01 lbf.in (4.52 N.m)
Rotor inertia	2.2 kg.cm ²
Resolution	1.8 °, 0.9 °, 0.72 °, 0.36 °, 0.18 °, 0.09 °, 0.072 °, 0.036 ° step angle 200, 400, 500, 1000, 2000, 4000, 5000, 10000 steps number of full steps per revolution
Accuracy error	+/- 6 arc min
Maximum starting frequency	5.3 kHz
Line Rated Current	2 A
Resistance	5.8 Ohm (winding)
Time constant	9 ms
Maximum radial force Fr	100 N (first shaft end) 50 N second shaft end)
Maximum axial force Fa	175 N tensile force) 30 N force pressure)
Service life in hours	20000 h bearing)
Angular acceleration	200000 rad/s ²
Net weight	7.05 lb(US) (3.2 kg)

The information provided in this documentation contains general descriptions and/or technical characteristics of the products of the products contained herein. This documentation is not intended as a substitute for and is not to be used for determining suitability or reliability of these products for specific user applications. It is the duty of any such user or integrator to perform the appropriate and complete risk analysis, evaluation and testing of the products with respect to the relevant specific application or use thereof. Neither Schneider Electric Industries SAS nor any of its affiliates or subsidiaries shall be responsible or liable for misuse of the information contained herein.

Environment

Standards	IEC 60072-1 EN 50347
Type of cooling	Natural convection
Ambient air temperature for operation	-13...104 °F (-25...40 °C)
Ambient air temperature for storage	-13...158 °F (-25...70 °C)
Operating altitude	<= 3280.84 ft (1000 m) without power derating
Relative humidity	15...85 % without condensation
Vibration resistance	20 m/s ² maximum A EN/IEC 60034-14
IP degree of protection	Shaft bushing IP56 EN/IEC 60034-5 Total except shaft bushing IP56 EN/IEC 60034-5
Temperature class	F winding IEC/EN 60034-1

Ordering and shipping details

Category	18284 - STEPPER MOTORS
Discount Schedule	PC55
GTIN	03389119223898
Nbr. of units in pkg.	1
Package weight(Lbs)	11.23 lb(US) (5.09 kg)
Returnability	No
Country of origin	DE

Packing Units

Unit Type of Package 1	PCE
Package 1 Height	8.86 in (22.5 cm)
Package 1 width	7.48 in (19 cm)
Package 1 Length	15.75 in (40 cm)

Contractual warranty

Warranty	18 months
----------	-----------

Dimensions

3-Phase Stepper Motor in Connector Version

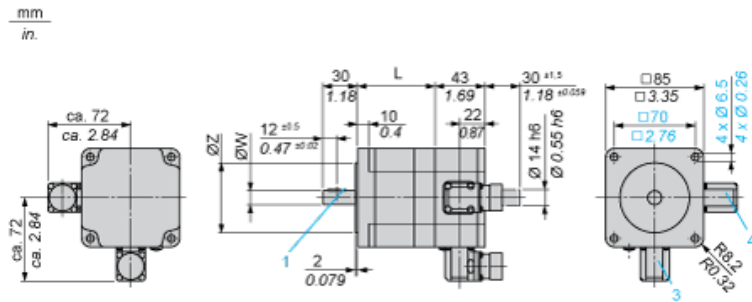

- 3 : Motor connection 6 poles
- 4 : Motor connection (optional) 12 poles

Holding Brake

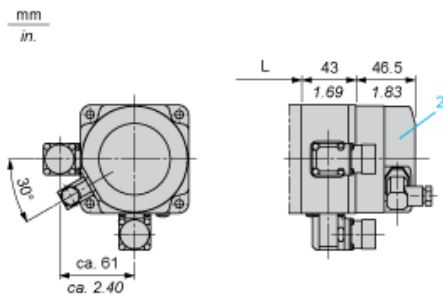

- 2 : Holding brake (optional)

Dimensions in mm

L	Shaft diameter ØW	Centring collar ØZ	Woodruff key DIN 6888 (1)
97.5 (+0.6) (-0.8)	12 h6	60 h8	4 x 6.5

Dimensions in in.

L	Shaft diameter ØW	Centring collar ØZ	Woodruff key DIN 6888 (1)
3.84 (+0.023) (-0.031)	0.47 h6	2.36 h8	0.16 x 0.25

Wiring Diagram of Holding Brake

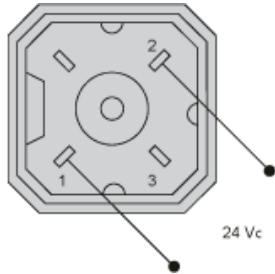

The connector is part of the scope of delivery. Connector designation: Hirschmann type G4 A 5M

Torque Characteristics

Measurement at 1000 Steps/Revolution, Nominal Voltage DC Bus U_N and Phase Current I_N

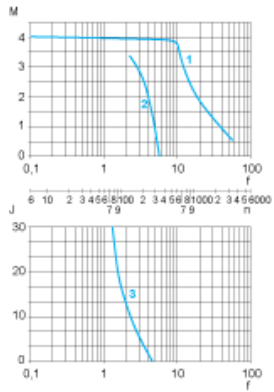

- M : Torque in Nm
- n : Speed in rpm
- f : Frequency in kHz
- J : Rotor inertia in kg.cm²
- 1 : Pull-out torque
- 2 : Pull-in torque
- 3 : Maximum load inertia