

AFS mine signal switch

APPLICATIONS:

AFS mine signal switches are used:

- For remote control of signaling circuits
- In non-hazardous areas of mines or process industry facilities where a rugged enclosure is needed for protection from falling ore and other material or dripping water
- Mounted on walls or in shaft ways and actuated by pulling line or cable attached to the loop at the bottom

FEATURES:

- Cast Feraloy® housing with water shedding cover
- Mounting lugs for ½" bolts or lag screws
- Single pole normally open double break switch contacts
- Switch is actuated by a spring-loaded plunger which returns to the normal position when the operating force is removed
- Standard pull spring on switch unit is 10 lbs
- Terminal block with heavy wire terminals is mounted in the box and readily accessible for ease of wiring
- Housing has ¾" NPT conduit hub on the bottom and slide-on steel, water shedding cover for convenient access
- No tools required, no screws to remove, no wiring to disturb for inspection or switch replacement

STANDARD MATERIALS:

- Enclosure – Feraloy® iron alloy
- Cover – sheet steel
- Plunger – steel
- Loop – bronze

STANDARD FINISHES:

- Feraloy® iron alloy – electrogalvanized and aluminum acrylic paint
- Steel – electrogalvanized
- Bronze – natural

ELECTRICAL RATING:

- Control circuit switch – 15 AMP, 125 VAC max.



AFS mine signal switch

ORDERING INFORMATION:

Maximum Weight of Line or Cable Without Actuating Switch (lbs.)	Total Operating Force Required (lbs.)	Cat #
7	10	AFS210-CD
10	15	AFS215-CD
25	50	AFS250-CD
75	100	AFS2100-CD

OPTIONS:

Description	Suffix
Finish: Corro-free™ epoxy powder coat – for coating outside only.	S752

DIMENSIONS (IN INCHES*):

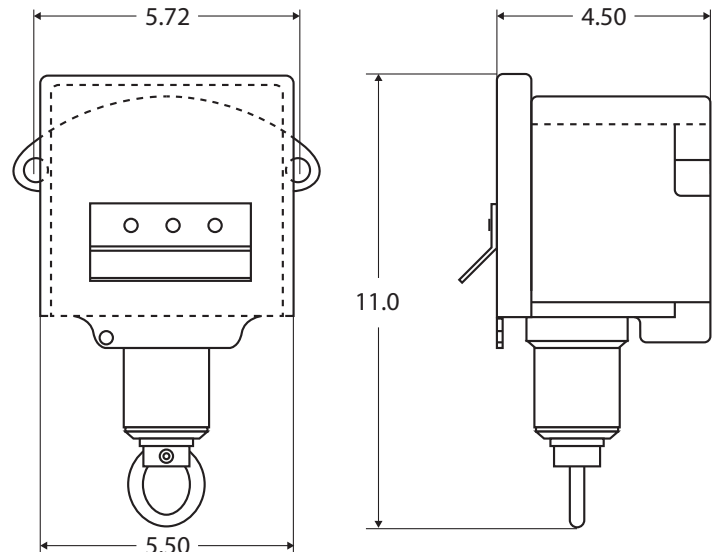

*Dimensions are approximate, not for construction purposes.