

## ORDERING INFORMATION

Order code: 62931  
 Description: BMH0100/TRITAP/C/HX/H/K/STD  
 UPC: 69549629318

## SPECIFICATIONS

Ballast type: Magnetic metal halide  
 Ballast style: Core and coil  
 Circuit type: HX-HPF  
 ANSI code: M90  
 Input voltage (V): 120/277/347  
 Input frequency (Hz): 60  
 Line volt regulation: 10 %  
 Line watt regulation: 10 %  
 Insulation class: H (180)

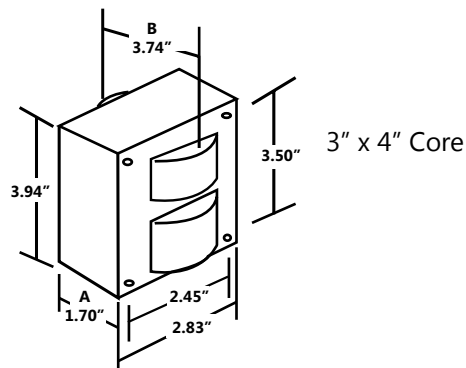
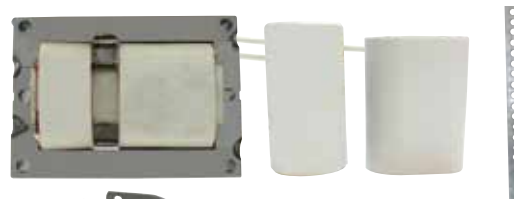

Input voltage (V)	Operating current (A)	Open circuit current (A)	Starting current (A)	Rated lamp watts (W)	Input watts (W)	OCV (V)	Dropout voltage (V)	UL 1029 code	Fuse rating (A)	Input current (A)	Power factor	Starting temperature
120	1.15	2.60	1.15	100	129	290	90	C	6	0.80 - 1.30	0.90	-20°F / -30°C
277	0.50	1.15	0.50	100	129	290	208	C	3	0.35 - 0.60	0.90	-20°F / -30°C
347	0.40	0.90	0.40	100	129	290	260	C	2	0.30 - 0.50	0.90	-20°F / -30°C

## HIGH POTENTIAL TEST (V)

1 minute:	2 000
2 seconds:	2 500
OCV test:	240 - 300
Short circuit:	1.3 - 1.65

## BALLAST DIMENSIONS

Dimension A:	1.70"
Dimension B:	3.74"
Lead lengths:	12" - 14"
Weight (lbs) :	5.07

## WIRING DIAGRAM

Ground ballast core

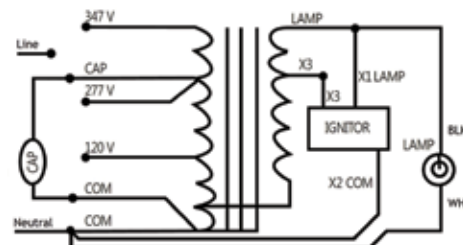

## BRACKET

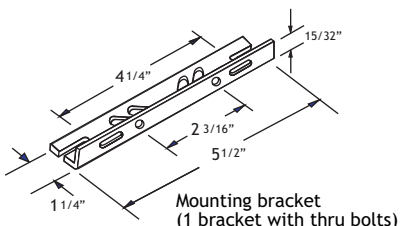

## CAPACITOR

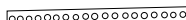
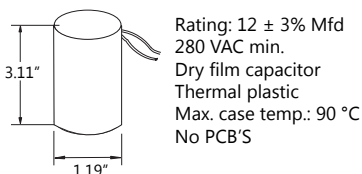

## IGNITOR

