



Main

Range of Product	Modicon M171
Product or Component Type	Display module
Display colour	Monochrome
Supply	External source

Complementary

Display Type	Backlit LCD screen
Number of key	4
Color	White
[Us] rated supply voltage	12 V DC
Power Consumption in W	0 W 5 W
Marking	CE
Realtime clock	With
Local signalling	LCD display
Product Compatibility	Logic controller M171 optimized
Height	5.39 in (137 mm)
Width	3.80 in (96.5 mm)
Depth	1.23 in (31.3 mm)
Net Weight	0.32 lb(US) (0.143 kg)

Environment

Product Certifications	cURus
IP degree of protection	Front face IP40

Ordering and shipping details

Category	22537-M171 / M172 HVAC CONTROLLERS
Discount Schedule	PC12
GTIN	3606480752650
Returnability	No
Country of origin	IT

Packing Units

Unit Type of Package 1	PCE
Number of Units in Package 1	1
Package 1 Height	5.12 in (13.0 cm)
Package 1 Width	3.58 in (9.1 cm)
Package 1 Length	7.28 in (18.5 cm)
Package 1 Weight	10.37 oz (294.0 g)
Unit Type of Package 2	S02

Number of Units in Package 2	6
Package 2 Height	5.91 in (15.0 cm)
Package 2 Width	11.81 in (30.0 cm)
Package 2 Length	15.75 in (40.0 cm)
Package 2 Weight	4.56 lb(US) (2.068 kg)

Offer Sustainability

California proposition 65	WARNING: This product can expose you to chemicals including: Lead and lead compounds, which is known to the State of California to cause cancer and birth defects or other reproductive harm. For more information go to www.P65Warnings.ca.gov
REACH Regulation	REACH Declaration
EU RoHS Directive	Pro-active compliance (Product out of EU RoHS legal scope)
Mercury free	Yes
China RoHS Regulation	China RoHS Declaration
RoHS exemption information	Yes
WEEE	The product must be disposed on European Union markets following specific waste collection and never end up in rubbish bins.
Upgradeability	Upgradeable through digital modules and upgraded components

Dimensions

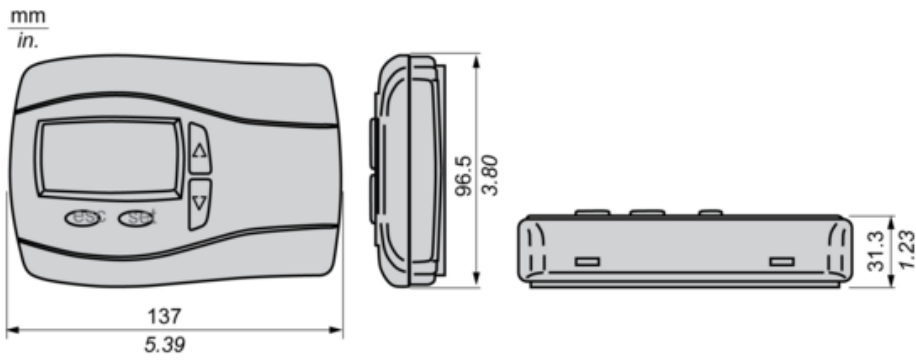

Mounting

mm
in.

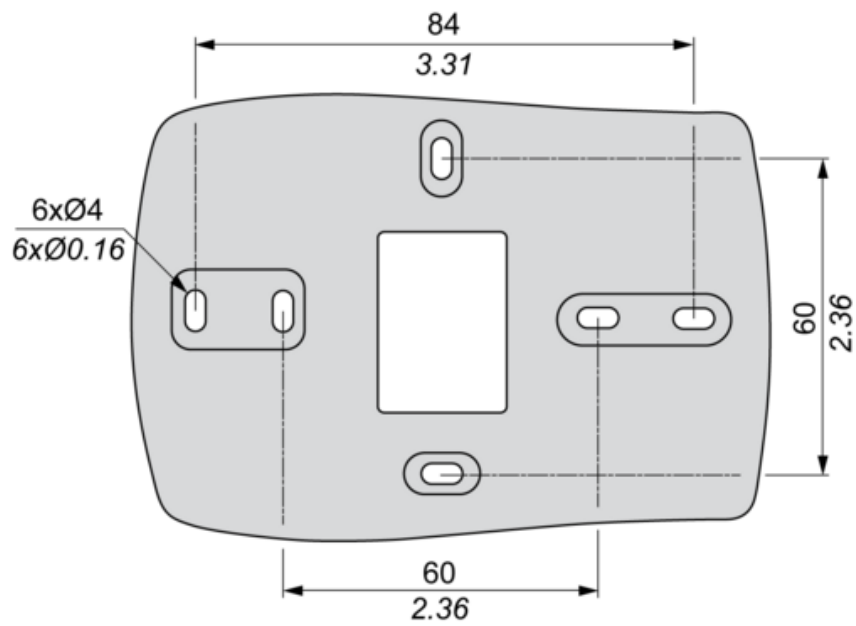

Wiring Diagram

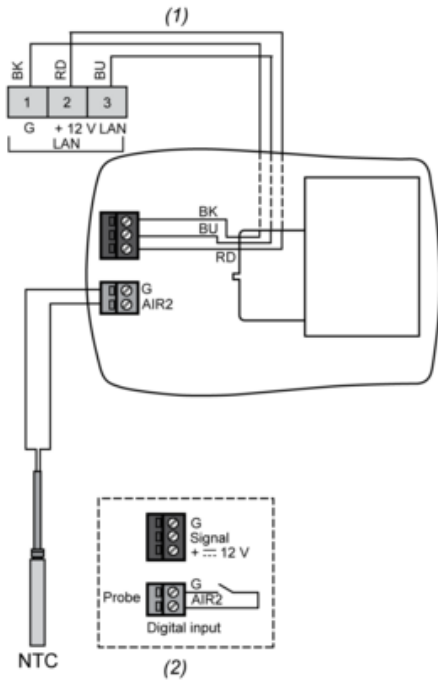

- (1) LAN Expansion bus
- (2) Remote probe not included

RD : Red
BU : Blue
BK : Black

Ex. Transducer

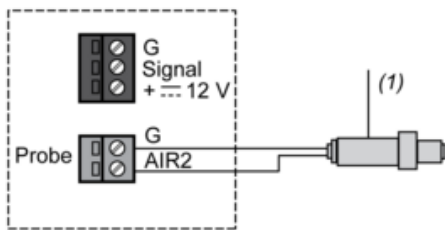

- (1) Power supply