

BMXDRA1605H

discrete output module, Modicon X80, 16 NO relay outputs, 24 to 240V AC, 24 to 48V DC, for severe environments



Main

Range of Product	Modicon X80
Product or Component Type	Discrete output module
Product Specific Application	For severe environments
Discrete output number	16 IEC 61131-2
Discrete output type	Relay
Discrete output voltage	24...48 V 19...60 V DC 24...240 V 19...264 V AC

Complementary

[I _{th}] conventional free air thermal current	2 A
Insulation resistance	> 10 MOhm 500 V DC
Power dissipation in W	3 W
Response time on output	< 8 ms activation < 10 ms deactivation
Typical current consumption	100 mA 3.3 V DC 95 mA 24 V DC
MTBF reliability	2100000 H
Output overload protection	Use 1 fast blow fuse per channel or group of channel
Output overvoltage protection	Use discharge diode on each output DC Use RC circuit on each output AC Use ZNO surge limiter on each output AC
Output short-circuit protection	Use 1 fast blow fuse per channel or group of channel
Minimum switching current	1 mA 5 V DC
Electrical durability	AC-15 100000 cycles 240 VA 200 V 0.7) AC-15 100000 cycles 120 VA 200 V 0.35) AC-12 100000 cycles 200 VA 100 V AC-12 100000 cycles 80 VA 48 V AC-12 100000 cycles 50 VA 24 V AC-15 100000 cycles 120 VA 100 V AC-15 100000 cycles 120 VA 24 V AC-15 100000 cycles 120 VA 48 V DC-12 100000 cycles 24 W 24 V DC-13 100000 cycles 10 W 24 V DC-13 100000 cycles 10 W 48 V AC-15 300000 cycles 72 VA 200 V 0.7) AC-15 300000 cycles 36 VA 200 V 0.35) AC-12 300000 cycles 200 VA 200 V AC-12 300000 cycles 80 VA 100 V AC-12 300000 cycles 50 VA 48 V AC-15 300000 cycles 36 VA 100 V AC-15 300000 cycles 72 VA 100 V AC-15 300000 cycles 36 VA 48 V AC-15 300000 cycles 72 VA 48 V AC-15 300000 cycles 36 VA 24 V AC-15 300000 cycles 72 VA 24 V DC-13 300000 cycles 3 W 24 V DC-13 300000 cycles 3 W 48 V DC-13 7000 cycles 24 W 24 V DC-13 7000 cycles 24 W 48 V DC-12 50000 cycles 24 W 48 V

The information provided in this documentation contains general descriptions and/or technical characteristics of the performance of the products contained herein. This documentation is not intended as a substitute for and is not to be used for determining suitability or reliability of these products for specific user applications. It is the duty of any such user or integrator to perform the appropriate and complete risk analysis, evaluation and testing of the products with respect to the relevant specific application or use thereof. Neither Schneider Electric Industries SAS nor any of its affiliates or subsidiaries shall be responsible or liable for misuse of the information contained herein.

Status LED	1 LED (Green) RUN 1 LED per channel (Green) channel diagnostic 1 LED (Red) ERR 1 LED (Red) I/O
Net Weight	0.33 lb(US) (0.15 kg)

Environment

IP Degree of Protection	IP20
Directives	2014/35/EU - low voltage directive 2014/30/EU - electromagnetic compatibility
Environmental characteristic	Gas resistant class Gx Gas resistant class 3C4 Dust resistant class 3S4 Sand resistant class 3S4 Salt resistant level 2 Mold growth resistant class 3B2 Fungal spore resistant class 3B2
Dielectric strength	2000 V AC 50/60 Hz 1 min
Vibration resistance	3 gn
Shock resistance	30 gn
Ambient Air Temperature for Storage	-40...185 °F (-40...85 °C)
Ambient Air Temperature for Operation	-13...158 °F (-25...70 °C)
Relative humidity	5...95 % 131 °F (55 °C) without condensation
Protective treatment	Conformal coating
Operating altitude	0...6561.68 ft (0...2000 m) 2000...5000 m with derating factor

Ordering and shipping details

Category	18160-MODICON M340
Discount Schedule	PC34
GTIN	3595864025803
Returnability	No
Country of origin	FR

Packing Units

Unit Type of Package 1	PCE
Number of Units in Package 1	1
Package 1 Height	2.17 in (5.5 cm)
Package 1 Width	4.33 in (11.0 cm)
Package 1 Length	4.57 in (11.6 cm)
Package 1 Weight	6.70 oz (190.0 g)
Unit Type of Package 2	S02
Number of Units in Package 2	15
Package 2 Height	5.91 in (15.0 cm)
Package 2 Width	11.81 in (30.0 cm)
Package 2 Length	15.75 in (40.0 cm)
Package 2 Weight	6.94 lb(US) (3.15 kg)

Offer Sustainability

California proposition 65	WARNING: This product can expose you to chemicals including: Lead and lead compounds, which is known to the State of California to cause cancer and birth defects or other reproductive harm. For more information go to www.P65Warnings.ca.gov
REACH Regulation	 REACH Declaration
EU RoHS Directive	Pro-active compliance (Product out of EU RoHS legal scope)
Mercury free	Yes
China RoHS Regulation	 China RoHS Declaration

RoHS exemption information



WEEE

The product must be disposed on European Union markets following specific waste collection and never end up in rubbish bins.

Contractual warranty

Warranty

18 months

Modules Mounted on Racks

Dimensions

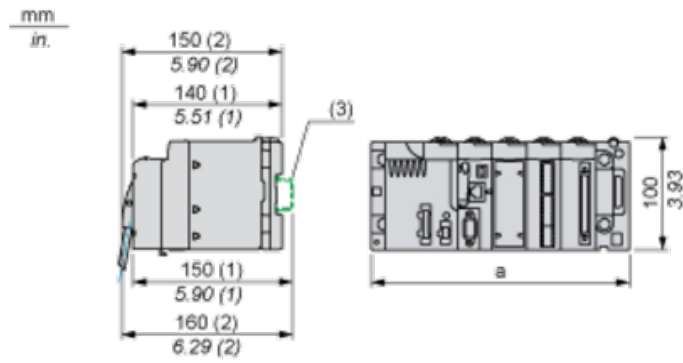

(1) With removable terminal block (cage, screw or spring).

(2) With FCN connector.

(3) On AM1 ED rail: 35 mm wide, 15 mm deep. Only possible with BMXXBP0400/0400H/0600/0600H/0800/0800H rack.

Rack references	a in mm	a in in.
BMXXBP0400 and BMXXBP0400H	242.4	09.54
BMXXBP0600 and BMXXBP0600H	307.6	12.11
BMXXBP0800 and BMXXBP0800H	372.8	14.68
BMXXBP1200 and BMXXBP1200H	503.2	19.81

Connecting the Module

Output Circuit Diagram

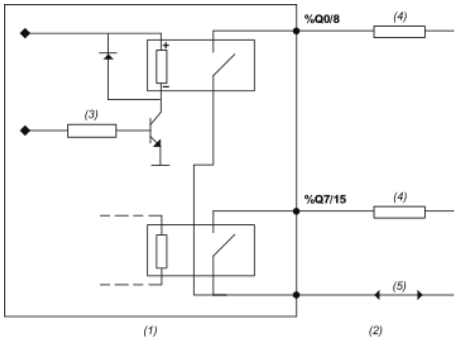

- (1) Module
- (2) Output
- (3) Command
- (4) Pre-actuator
- (5) Power supply

Module Connection

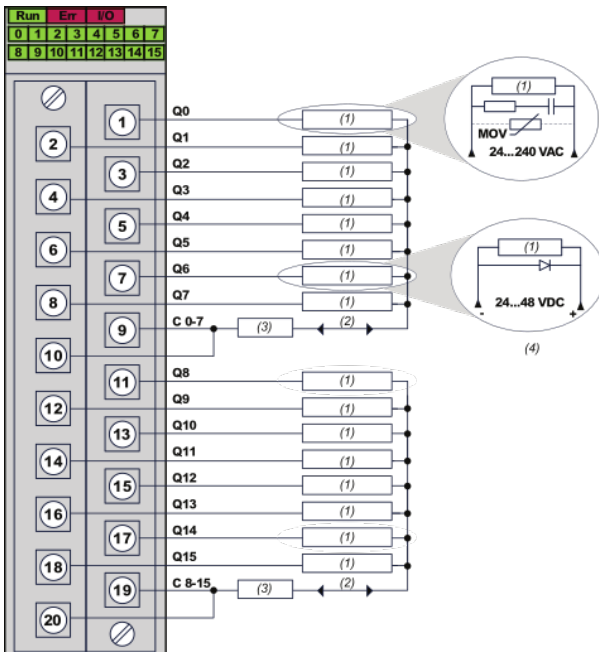

- (1) Pre-actuator
- (2) Power supply : 24...48 VDC or 24...240 VAC
- (3) Fuse : 1 fast blow fuse of 12 A for each 8-channel group
- (4) We recommend installing this type of protection on the terminals of each pre-actuator