

ORDERING INFORMATION

Order code: 59639
 Description: BMHP0400/TRITAP/C/CWA/H STD
 UPC: 69549596399



SPECIFICATIONS

Ballast type: Magnetic metal halide
 Ballast style: Core and coil
 Circuit type: CWA
 ANSI code: M135/M155
 Input voltage (V): 120/277/347
 Input frequency (Hz): 60
 Line volt regulation: $\pm 10\%$
 Line watt regulation: $\pm 10\%$
 Insulation class: H (180°)

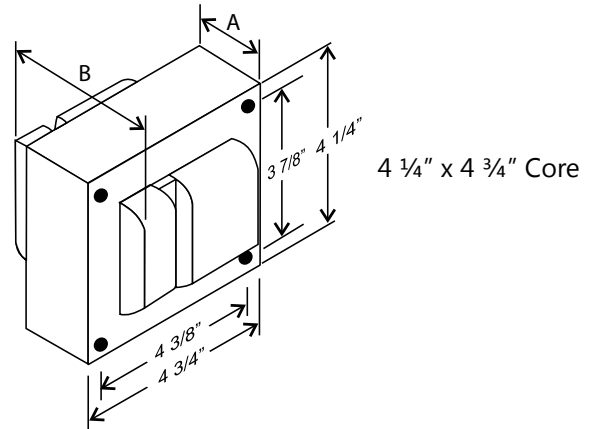

Input voltage (V)	Operating current (A)	Open circuit current (A)	Starting current (A)	Rated lamp watts (W)	Input watts (W)	OCV (V)	Dropout voltage (V)	UL 1029 code	Fuse rating (A)	Input current (A)	Power factor	Starting temperature
120	3.80	3.00	2.15	400	452	270	60	E	10	1.62 - 2.35	0.90	-20°F / -30°C
277	1.70	1.30	0.95	400	452	270	138	E	5	0.65 - 1.05	0.90	-20°F / -30°C
347	1.40	1.00	0.75	400	452	270	175	E	4	0.55 - 0.85	0.90	-20°F / -30°C

HIGH POTENTIAL TEST (V)

1 minute:	2 000
2 seconds:	2 500
OCV test:	245 - 300
Short circuit:	3.50 - 4.30

BALLAST DIMENSIONS

Dimension A:	1.80"
Dimension B:	3.70"
Lead Lengths:	12.00"
Weight (lbs):	12.25

WIRING DIAGRAM

Ground ballast core

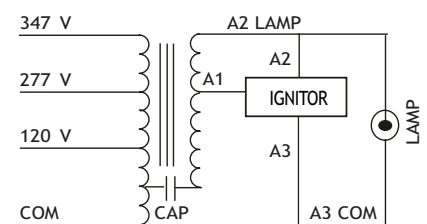

BRACKET

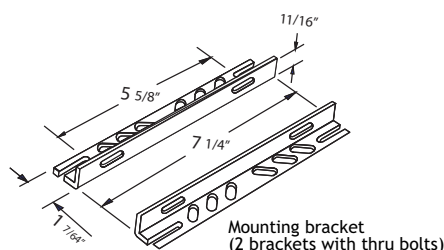

CAPACITOR

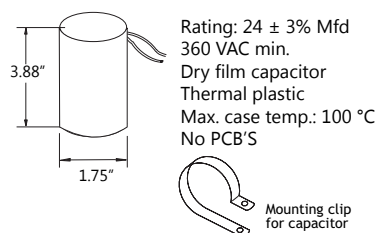

IGNITOR

