

ORDERING INFORMATION

Order code: 10021
 Description: BHPS0070/120/C/R/K/STD
 UPC: 69549100213

SPECIFICATIONS

Ballast type: Magnetic high pressure sodium
 Ballast style: Core and coil
 Circuit type: R-NPF (HPF with capacitor)
 ANSI code: S62
 Input voltage (V): 120
 Input frequency (Hz): 60
 Line volt regulation: $\pm 5\%$
 Line watt regulation: Within trapezoid
 Insulation class: H (180°)

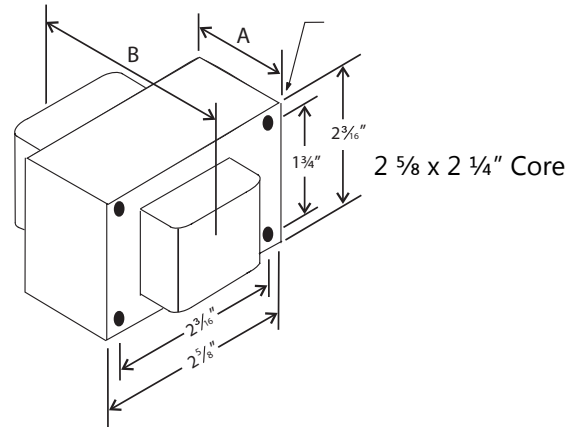

Input voltage (V)	Operating current (A)	Open circuit current (A)	Starting current (A)	Rated lamp watts (W)	Input watts (W)	OCV (V)	Dropout voltage (V)	UL 1029 code	Fuse rating (A)	Input current (A)	Power factor	Starting temperature
120	1.60	0.00	2.05	70	80	120	95	A	8	1.72 - 2.10	0.45 NPF	-40°F / -40°C
120	0.70	1.30	0.90	70	80	120	95	A	4	0.62 - 0.78	0.90 HPF with cap.	-40°F / -40°C

HIGH POTENTIAL TEST (V)

1 minute:	2 000
2 seconds:	2 500
OCV test:	114 - 126
Short circuit:	1.80 - 2.10

BALLAST DIMENSIONS

Dimension A:	1.30"
Dimension B:	2.25"
Lead Lengths:	12.00"
Weight (lbs):	2.13

WIRING DIAGRAM

Ground ballast core

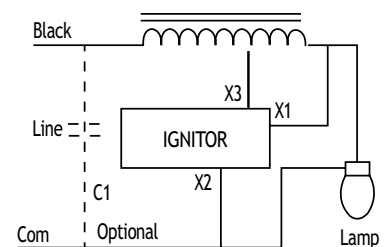

BRACKET

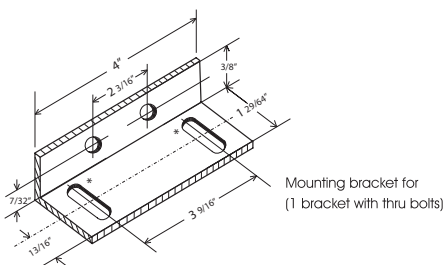

CAPACITOR

(Optional)

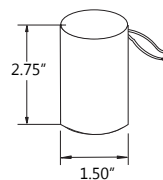

Rating: $28 \pm 3\%$ Mfd
 120 VAC min.
 Dry film capacitor
 Thermal plastic
 Max. case temp.: 90 °C
 No PCB'S



IGNITOR

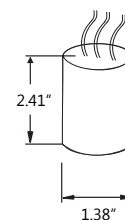

Ballast to lamp distance (BTL): 2'
 Thermal plastic
 Max. case temp.: 110 °C

