

Product data sheet

Characteristics

ZB5AZ022

Flush mounting kit, Harmony XB5, mounting kit 30mm for selector switches and illuminated push buttons 22mm, plastic



Main

| | |
|---------------------------------------|--|
| Range of Product | Harmony XB5 |
| Product or Component Type | Flush mounting kit |
| Accessory / separate part category | Mounting and fixing accessory |
| Product Compatibility | ZB5AD ZB5RTA ZB5AD.8 ZB5RZA0 ZB5AK ZB5AA.6 ZB5AD.9 ZB5AJ ZB5AW ZB5AH..3 |
| Accessory / separate part destination | Selector switch high bezel high guard Illuminated push-button high bezel high guard |

Complementary

| | |
|-------------------------|---|
| Colour | Black |
| IP degree of protection | IP66 IEC 60529 front face) IP69 IEC 60529 front face) IP69K DIN 40050-9 front face) |
| IK degree of protection | IK03 IEC 50102 |
| Mounting diameter | 1.20 in (30.5 mm) |
| Quantity per Set | Set of 1 |

Ordering and shipping details

| | |
|-------------------|---------------------------------|
| Category | 18079-SPARE PARTS DISCOUNT CP10 |
| Discount Schedule | CP10 |
| GTIN | 3606485440231 |
| Returnability | No |
| Country of origin | FR |

Packing Units

| | |
|------------------------------|------------------------|
| Unit Type of Package 1 | PCE |
| Number of Units in Package 1 | 1 |
| Package 1 Height | 2.05 in (5.2 cm) |
| Package 1 Width | 2.17 in (5.5 cm) |
| Package 1 Length | 2.24 in (5.7 cm) |
| Package 1 Weight | 0.53 oz (15.0 g) |
| Unit Type of Package 2 | S02 |
| Number of Units in Package 2 | 80 |
| Package 2 Height | 5.91 in (15.0 cm) |
| Package 2 Width | 11.81 in (30.0 cm) |
| Package 2 Length | 15.75 in (40.0 cm) |
| Package 2 Weight | 3.58 lb(US) (1.622 kg) |

Dimensions with Flush Mounting Kit

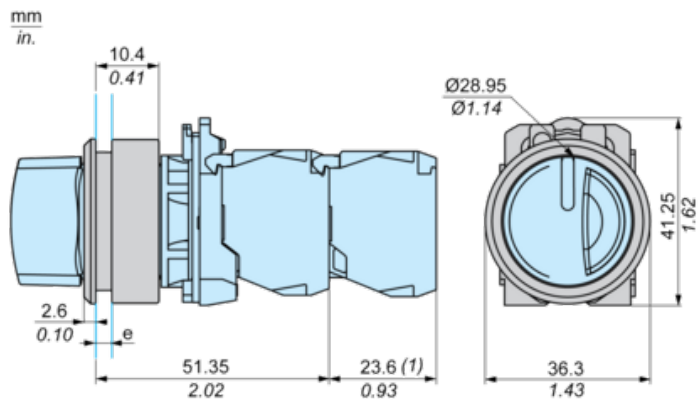

e : Clamping thickness : 1 to 3.5 mm / 0.04 to 0.14 in.

(1) Additional row of contacts or double contact

Panel Cut-Out and Mounting

