

CAT. NO.: PDB-11-350-3

MASS:

TOLERANCES-UNLESS OTHERWISE SPECIFIED
2 PL. DEC. ±.015 TRUE CL. ±.015
3 PL. DEC. ±.015 ANGLES ±1

DWG. NO.
M2564
SHEET 1 OF 1



DRAWN BY: CLH
DATE: 12/20/2007

SCALE:
SIZE: B

REV.	DESCRIPTION
H	

Cat #: PDB-11-350-3

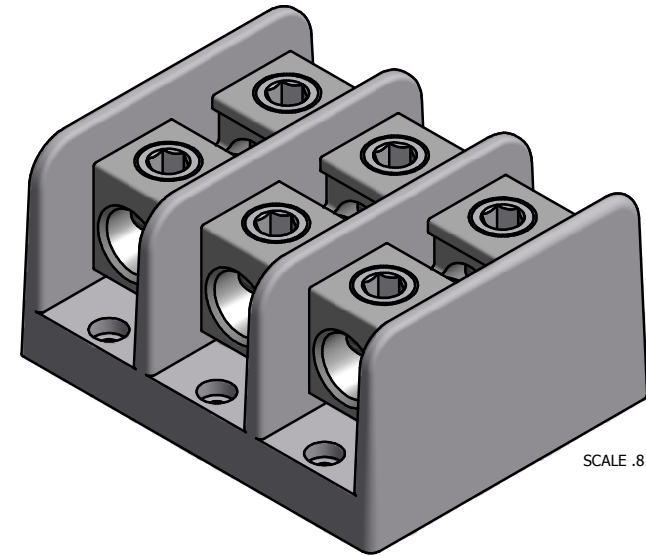
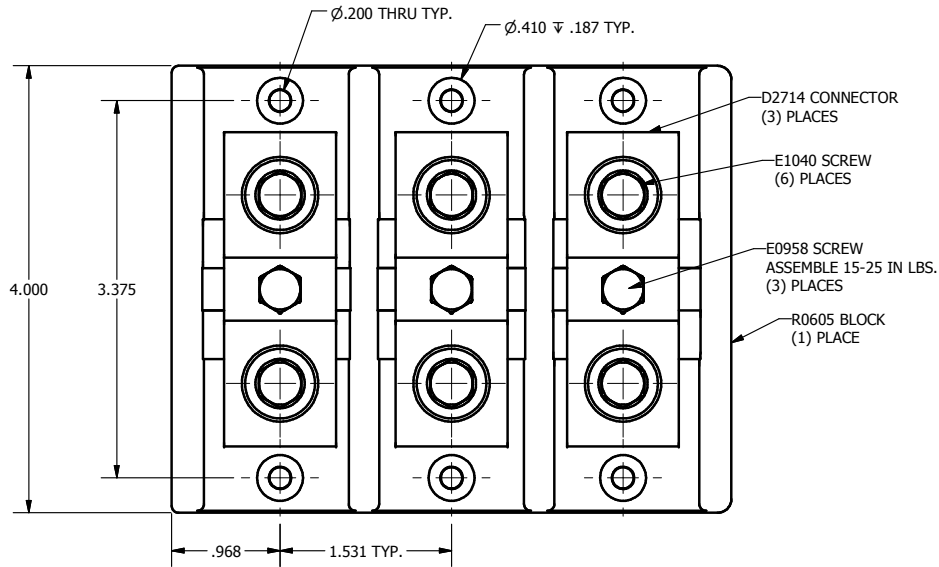

SCALE .8 : 1

