

BCH2MM1523CA6C

servo motor BCH, Lexium 28, 130mm, 1500W, 9.7kg.cm², with oil seal, with key, straight connection



Main

Range Compatibility	Lexium 28
Product or Component Type	Servo motor
Device short name	BCH2

Complementary

Maximum mechanical speed	3000 rpm
[Us] rated supply voltage	220 V
Phase	Single phase Three phase
Continuous stall current	6.18 A
Continuous stall torque	63.37 Lbf.in (7.16 N.m) LXM26D 7 A, 220 V, single phase 63.37 Lbf.in (7.16 N.m) LXM26D 7 A, 220 V, three phase 63.37 Lbf.in (7.16 N.m) LXM28... 7 A, 220 V, single phase 63.37 lbf.in (7.16 N.m) LXM28... 7 A, 220 V, three phase
Continuous power	1500 W
Peak stall torque	190.11 Lbf.in (21.48 N.m) LXM26D 7 A, 220 V, single phase 190.11 Lbf.in (21.48 N.m) LXM26D 7 A, 220 V, three phase 190.11 Lbf.in (21.48 N.m) LXM28... 7 A, 220 V, single phase 190.11 lbf.in (21.48 N.m) LXM28... 7 A, 220 V, three phase
Nominal output power	1500 W LXM26D 7 A, 220 V, single phase 1500 W LXM26D 7 A, 220 V, three phase 1500 W LXM28... 7 A, 220 V, single phase 1500 W LXM28... 7 A, 220 V, three phase
Nominal torque	63.37 Lbf.in (7.16 N.m) LXM26D 7 A, 220 V, single phase 63.37 Lbf.in (7.16 N.m) LXM26D 7 A, 220 V, three phase 63.37 Lbf.in (7.16 N.m) LXM28... 7 A, 220 V, single phase 63.37 lbf.in (7.16 N.m) LXM28... 7 A, 220 V, three phase
Nominal speed	2000 rpm LXM26D 7 A, 220 V, single phase 2000 rpm LXM26D 7 A, 220 V, three phase 2000 rpm LXM28... 7 A, 220 V, single phase 2000 rpm LXM28... 7 A, 220 V, three phase
Maximum current Irms	20.31 A LXM28... 1.5 kW, 220 V
Maximum permanent current	6.74 A
Product compatibility	LXM26D servo drive 1.5 kW, 220 V, single phase LXM26D servo drive 1.5 kW, 220 V, three phase LXM28... servo drive 1.5 kW, 220 V, single phase LXM28... servo drive 1.5 kW, 220 V, three phase
Shaft end	Keyed
Shaft diameter	0.87 in (22 mm)
Shaft length	2.17 in (55 mm)
Key width	0.31 in (8 mm)
Feedback type	20 bits single turn absolute encoder
Holding brake	Without

The information provided in this documentation contains general descriptions and/or technical characteristics of the performance of the products contained herein. This documentation is not intended as a substitute for and is not to be used for determining suitability or reliability of these products for specific user applications. It is the duty of any such user or integrator to perform the appropriate and complete risk analysis, evaluation and testing of the products with respect to the relevant specific application or use thereof. Neither Schneider Electric Industries SAS nor any of its affiliates or subsidiaries shall be responsible or liable for misuse of the information contained herein.

Mounting Support	Asian standard flange
Motor flange size	5.12 in (130 mm)
Electrical connection	Connector MIL
Torque constant	1.16 N.m/A 68 °F (20 °C)
Back emf constant	70 V/krpm 68 °F (20 °C)
Rotor inertia	9.7 kg.cm ²
Stator resistance	0.64 Ohm 68 °F (20 °C)
Stator inductance	6.4 mH 68 °F (20 °C)
Stator electrical time constant	10 ms 68 °F (20 °C)
Maximum radial force Fr	670 N 2000 rpm
Maximum axial force Fa	200 N
Brake pull-in power	19.7 W
Type of cooling	Natural convection
Length	6.57 in (167 mm)
Number of motor stacks	3
Centring collar diameter	4.33 in (110 mm)
Centring collar depth	0.31 in (8 mm)
Number of mounting holes	4
Mounting holes diameter	0.36 in (9.2 mm)
Circle diameter of the mounting holes	5.71 in (145 mm)
Distance shaft shoulder-flange	0.31 in (8 mm)
Net Weight	16.76 lb(US) (7.6 kg)

Environment

IP Degree of Protection	IP50 IM V3 IP65 IM B5, IM V1
Ambient Air Temperature for Operation	-4...104 °F (-20...40 °C)

Ordering and shipping details

Category	18281-LEXIUM 23/28 MOTORS
Discount Schedule	PC53
GTIN	3606480734342
Returnability	No
Country of origin	CN

Packing Units

Unit Type of Package 1	PCE
Number of Units in Package 1	1
Package 1 Height	7.83 in (19.9 cm)
Package 1 Width	9.29 in (23.6 cm)
Package 1 Length	14.37 in (36.5 cm)
Package 1 Weight	21.89 lb(US) (9.93 kg)
Unit Type of Package 2	S06
Number of Units in Package 2	9
Package 2 Height	28.94 in (73.5 cm)
Package 2 Width	23.62 in (60.0 cm)
Package 2 Length	31.50 in (80.0 cm)
Package 2 Weight	209.44 lb(US) (95.0 kg)

Offer Sustainability

Sustainable offer status	Green Premium product
California proposition 65	WARNING: This product can expose you to chemicals including: Lead and lead compounds, which is known to the State of California to cause cancer and birth defects or other reproductive harm. For more information go to www.P65Warnings.ca.gov
REACH Regulation	REACH Declaration
REACH free of SVHC	Yes
EU RoHS Directive	Pro-active compliance (Product out of EU RoHS legal scope)
Mercury free	Yes
China RoHS Regulation	China RoHS Declaration
RoHS exemption information	Yes
Environmental Disclosure	Product Environmental Profile
Circularity Profile	End Of Life Information
WEEE	The product must be disposed on European Union markets following specific waste collection and never end up in rubbish bins.
PVC free	Yes

Dimensions

Dimensions of Motor

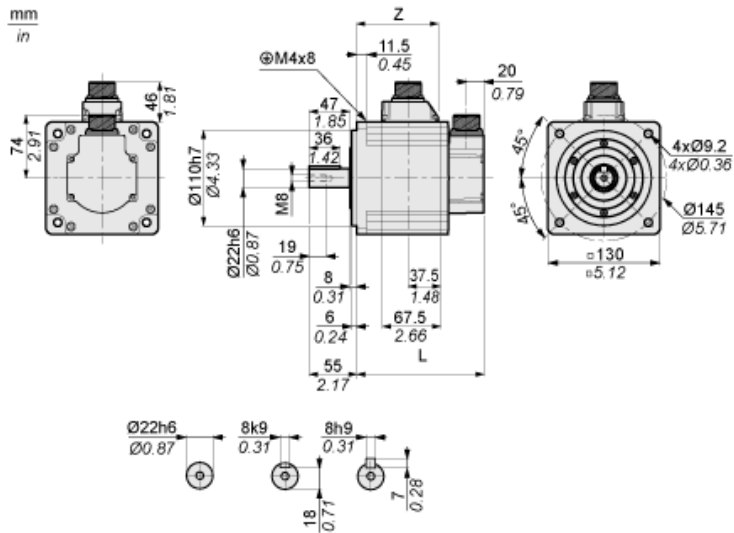

	mm	in.
L (without holding brake)	167	6.57
L (with holding brake)	202	7.95
Z	114.5	4.51

Torque/Speed Curves with 230 V Single/Three Phase Supply Voltage

Servo Motor with LXM28AU15●●● Servo Drive

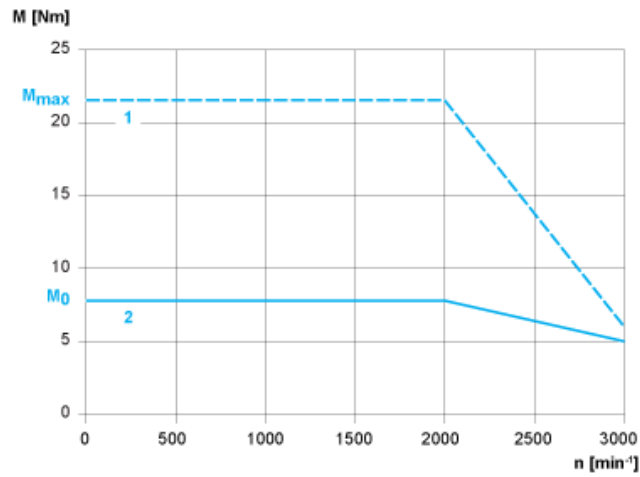

- 1 : Peak torque
- 2 : Continuous torque