



## Main

Range compatibility	Lexium 28
Product or component type	Servo motor
Device short name	BCH2

## Complementary

Maximum mechanical speed	5000 rpm
[Us] rated supply voltage	220 V
Phase	Three phase Single phase
Continuous stall current	5.83 A
Continuous stall torque	28.15 Lbf.In (3.18 N.m) LXM28... 7 A, 220 V, single phase 28.15 lbf.in (3.18 N.m) LXM28... 7 A, 220 V, three phase
Continuous power	1000 W
Peak stall torque	84.44 Lbf.In (9.54 N.m) LXM28... 7 A, 220 V, single phase 84.44 lbf.in (9.54 N.m) LXM28... 7 A, 220 V, three phase
Nominal output power	1000 W LXM28... 7 A, 220 V, single phase 1000 W LXM28... 7 A, 220 V, three phase
Nominal torque	28.15 Lbf.In (3.18 N.m) LXM28... 7 A, 220 V, single phase 28.15 lbf.in (3.18 N.m) LXM28... 7 A, 220 V, three phase
Nominal speed	3000 rpm LXM28... 7 A, 220 V, single phase 3000 rpm LXM28... 7 A, 220 V, three phase
Maximum current Irms	18.9 A LXM28... 1 kW, 220 V
Maximum permanent current	6.64 A
Product compatibility	LXM28... servo drive 1 kW, 220 V, single phase LXM28... servo drive 1 kW, 220 V, three phase
Shaft end	Keyed
Shaft diameter	0.87 in (22 mm)
Shaft length	1.77 in (45 mm)
Key width	0.31 in (8 mm)
Feedback type	20 bits single turn absolute encoder
Holding brake	Without
Mounting support	Asian standard flange
Motor flange size	3.94 in (100 mm)
Electrical connection	Connector MIL
Torque constant	0.55 N.m/A 68 °F (20 °C)
Back emf constant	33 V/krpm 68 °F (20 °C)
Rotor inertia	2.4 kg.cm <sup>2</sup>
Stator resistance	0.67 Ohm 68 °F (20 °C)
Stator inductance	4.2 mH 68 °F (20 °C)
Stator electrical time constant	6.27 ms 68 °F (20 °C)
Maximum radial force Fr	570 N 3000 rpm

Maximum axial force Fa	200 N
Brake pull-in power	10.4 W
Type of cooling	Natural convection
Length	6.04 in (153.5 mm)
Number of motor stacks	1
Centring collar diameter	3.74 in (95 mm)
Centring collar depth	0.28 in (7 mm)
Number of mounting holes	4
Mounting holes diameter	0.36 in (9.2 mm)
Circle diameter of the mounting holes	4.53 in (115 mm)
Distance shaft shoulder-flange	0.28 in (7 mm)
Net Weight	10.14 lb(US) (4.6 kg)

## Environment

IP degree of protection	IP54 IM B5, IM V1 IP50 IM V3
Ambient air temperature for operation	-4...104 °F (-20...40 °C)

## Ordering and shipping details

Category	18281 - LEXIUM 23/28 MOTORS
Discount Schedule	PC53
GTIN	03606480733987
Nbr. of units in pkg.	1
Package weight(Lbs)	1 lb(US) (0.45 kg)
Returnability	No
Country of origin	CN

## Packing Units

Unit Type of Package 1	PCE
Package 1 Height	7.13 in (18.1 cm)
Package 1 width	9.06 in (23 cm)
Package 1 Length	14.17 in (36 cm)

## Offer Sustainability

Sustainable offer status	Green Premium product
California proposition 65	WARNING: This product can expose you to chemicals including: Lead and lead compounds, which is known to the State of California to cause cancer and birth defects or other reproductive harm. For more information go to <a href="http://www.P65Warnings.ca.gov">www.P65Warnings.ca.gov</a>
REACH Regulation	<a href="#">REACH Declaration</a>
REACH free of SVHC	Yes
EU RoHS Directive	Pro-active compliance (Product out of EU RoHS legal scope) <a href="#">EU RoHS Declaration</a>
Mercury free	Yes
RoHS exemption information	<a href="#">Yes</a>
China RoHS Regulation	<a href="#">China RoHS Declaration</a>
Environmental Disclosure	<a href="#">Product Environmental Profile</a>
Circularity Profile	<a href="#">End Of Life Information</a>
WEEE	The product must be disposed on European Union markets following specific waste collection and never end up in rubbish bins.
PVC free	Yes

Dimensions

Dimensions of Motor

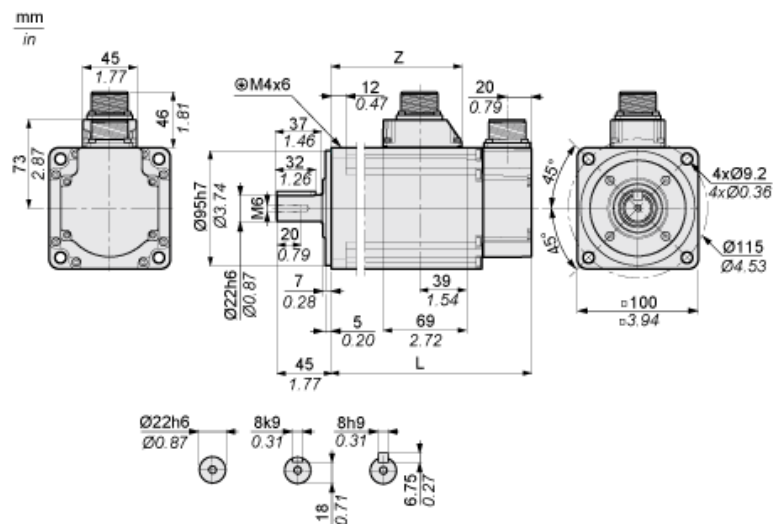

	mm	in.
L (without holding brake)	153.5	6.04
L (with holding brake)	180.5	7.11
Z	96	3.78

Torque/Speed Curves with 230 V Single/Three Phase Supply Voltage

Servo Motor with LXM28AU10●●● Servo Drive

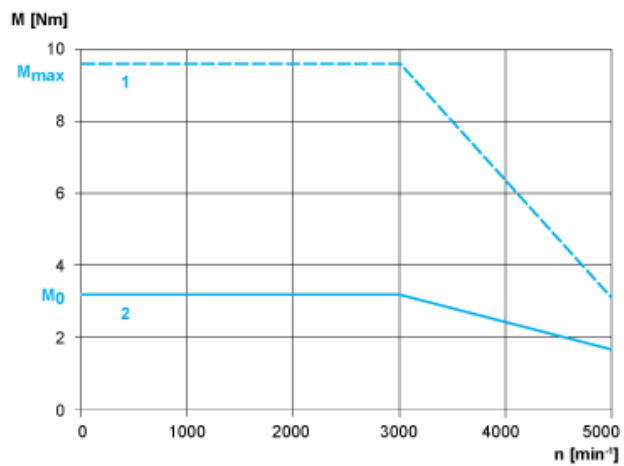

- 1 : Peak torque
- 2 : Continuous torque