



## Main

Range of Product	Lexium 28
Product or Component Type	Motion servo drive
Device short name	LXM28A
Format of the drive	Compact housing
Line current	17.9 A 147.1 % 220 V, three phase

## Complementary

Phase	Three phase
[Us] rated supply voltage	200...240 V - 10...15 %)three phase
Supply voltage limits	200...255 V three phase
Supply frequency	50/60 Hz - 5...5 %
Network Frequency	47.5...63 Hz
EMC filter	Without EMC filter
Continuous output current	22.9 A 8 kHz
Output current 3s peak	61 A 220 V
Continuous power	4500 W 220 V
Nominal power	4.5 kW 220 V 8 kHz
Switching frequency	8 kHz
Overvoltage category	III
Maximum leakage current	1.55 mA
Output voltage	<= power supply voltage
Electrical isolation	Between power and control
Type of cable	Shielded motor cable 32...131 °F (0...55 °C)) copper
Electrical connection	Spring terminal 6 mm <sup>2</sup> , AWG 10 L1-L2) Spring terminal 6 mm <sup>2</sup> , AWG 10 R, S, T) Spring terminal 6 mm <sup>2</sup> , AWG 10 U, V, W, PE) Spring terminal 6 mm <sup>2</sup> , AWG 10 PA/+, PBe)
Discrete input number	8 programmable CN1) 1 pulse train input (PTI) CN1) 2 fast capture CN1) 1 safety function STO CN9)
Discrete input voltage	24 V DC logic
Discrete input logic	Positive or negative CN1)
Discrete output number	5 logic output CN1)12...24 V DC 1 pulse train output (PTO) CN1)
Discrete output voltage	12...24 V DC
Discrete output logic	Positive or negative CN1)
Analogue input number	2
Absolute accuracy error	0.1 %
Analogue input type	V_REF voltage analog input - 10...10 V 10 kOhm 14 bits T_REF voltage analog input
Control signal type	Servo motor encoder feedback CN2

Protection type	Against reverse polarity inputs signal Against short-circuits outputs signal Overcurrent motor Overvoltage motor Undervoltage motor Overheating motor Overload motor Overspeed motor
Safety function	STO (safe torque off), Integrated
Safety level	SIL 2 IEC 61800-5-2 2007 SIL 2 IEC 61508-1 2010 PL d/category 3 ISO 13849-1 2008 SIL 2 ISO 13849-1 2009/AC SIL 2 IEC 60204-1 2006 SIL 2 IEC 60204-1 2009/A1 SIL 2 IEC 60204-1 2010/AC SIL 2 IEC 62061 2012
Communication interface	CANopen, Integrated CANmotion, Integrated
Connector type	RJ45 CN4)CANopen, CANmotion
Method of access	Slave
Transmission rate	250 kbit/s 328.08...820.21 ft (100...250 m) CANopen, CANmotion 500 kbit/s 13.12...328.08 ft (4...100 m) CANopen, CANmotion 1 Mbit/s 13.12 ft (4 m) CANopen, CANmotion
Number of addresses	1...127 CANopen, CANmotion
Physical interface	RS485 Modbus Serial line slave
Status LED	1 LED (Red) charge 1 LED (Green) RUN 1 LED (Red) error
Signalling function	Servo status and fault codes five 7-segment display units
Marking	CULus CSA CE
Type of cooling	Integrated fan
Operating position	Vertical
Product compatibility	Servo motor BCH2 7.09 in (180 mm), 3 4500 W Servo motor BCH2 7.09 in (180 mm), 2 3500 W
Width	4.57 in (116 mm)
Height	9.21 in (234 mm)
Depth	7.32 in (186 mm)
Net Weight	7.05 lb(US) (3.2 kg)
Output current 3s peak 2	61 A 220 V
Output current 3s peak 3	61 A 220 V

## Environment

Electromagnetic compatibility	Conducted emission - test level: level 3 category C3 conforming to IEC 61800-3
Standards	IEC 61800-5-1
Product Certifications	cULus[RETURN]CSA[RETURN]CE
IP degree of protection	IP20
Vibration resistance	3M4 3 mm 9...200 Hz)IEC 60721-3-3
Shock resistance	10 gn, type I IEC 60721-3-3
Relative humidity	5...95 % without condensation
Ambient Air Temperature for Operation	32...131 °F (0...55 °C)
Ambient Air Temperature for Storage	-13...149 °F (-25...65 °C)
Operating altitude	<= 3280.84 ft (1000 m) without derating > 3280.84...6561.68 ft (> 1000...2000 m) 1 % per 100 m

## Ordering and shipping details

Category	18262-LEXIUM 23/28 SERVO DRIVES
Discount Schedule	PC51
GTIN	3606480711848
Returnability	No
Country of origin	CN

## Packing Units

Unit Type of Package 1	PCE
Number of Units in Package 1	1
Package 1 Height	7.72 in (19.6 cm)
Package 1 Width	10.16 in (25.8 cm)
Package 1 Length	13.66 in (34.7 cm)
Package 1 Weight	11.00 lb(US) (4.988 kg)

## Offer Sustainability

Sustainable offer status	Green Premium product
California proposition 65	WARNING: This product can expose you to chemicals including: Lead and lead compounds, which is known to the State of California to cause cancer and birth defects or other reproductive harm. For more information go to <a href="http://www.P65Warnings.ca.gov">www.P65Warnings.ca.gov</a>
REACH Regulation	<a href="#">REACH Declaration</a>
REACH free of SVHC	Yes
EU RoHS Directive	Pro-active compliance (Product out of EU RoHS legal scope)
Mercury free	Yes
China RoHS Regulation	<a href="#">China RoHS Declaration</a>
RoHS exemption information	<a href="#">Yes</a>
Environmental Disclosure	<a href="#">Product Environmental Profile</a>
Circularity Profile	<a href="#">End Of Life Information</a>
WEEE	The product must be disposed on European Union markets following specific waste collection and never end up in rubbish bins.
PVC free	Yes

Dimensions

Dimensions of Drive

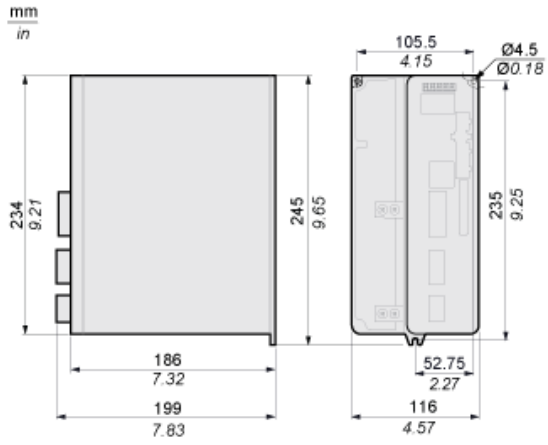

Mounting Clearance

Mounting Distances and Air Circulation

mm  
in.

