

BCH2LH1033CA6C

servo motor BCH, Lexium 28, 100mm, 1000W, 2.4kg.cm², with oil seal, with key, straight connection



Main

Range Compatibility	Lexium 28
Product or Component Type	Servo motor
Device short name	BCH2

Complementary

Maximum mechanical speed	5000 rpm
[Us] rated supply voltage	220 V
Phase	Single phase Three phase
Continuous stall current	5.83 A
Continuous stall torque	28.15 Lbf.in (3.18 N.m) LXM26D 7 A, 220 V, single phase 28.15 Lbf.in (3.18 N.m) LXM26D 7 A, 220 V, three phase 28.15 Lbf.in (3.18 N.m) LXM28... 7 A, 220 V, single phase 28.15 lbf.in (3.18 N.m) LXM28... 7 A, 220 V, three phase
Continuous power	1000 W
Peak stall torque	84.44 Lbf.in (9.54 N.m) LXM26D 7 A, 220 V, single phase 84.44 Lbf.in (9.54 N.m) LXM26D 7 A, 220 V, three phase 84.44 Lbf.in (9.54 N.m) LXM28... 7 A, 220 V, single phase 84.44 lbf.in (9.54 N.m) LXM28... 7 A, 220 V, three phase
Nominal output power	1000 W LXM26D 7 A, 220 V, single phase 1000 W LXM26D 7 A, 220 V, three phase 1000 W LXM28... 7 A, 220 V, single phase 1000 W LXM28... 7 A, 220 V, three phase
Nominal torque	28.15 Lbf.in (3.18 N.m) LXM26D 7 A, 220 V, single phase 28.15 Lbf.in (3.18 N.m) LXM26D 7 A, 220 V, three phase 28.15 Lbf.in (3.18 N.m) LXM28... 7 A, 220 V, single phase 28.15 lbf.in (3.18 N.m) LXM28... 7 A, 220 V, three phase
Nominal speed	3000 rpm LXM26D 7 A, 220 V, single phase 3000 rpm LXM26D 7 A, 220 V, three phase 3000 rpm LXM28... 7 A, 220 V, single phase 3000 rpm LXM28... 7 A, 220 V, three phase
Maximum current Irms	18.9 A LXM28... 1 kW, 220 V
Maximum permanent current	6.64 A
Product compatibility	LXM26D servo drive 1 kW, 220 V, single phase LXM26D servo drive 1 kW, 220 V, three phase LXM28... servo drive 1 kW, 220 V, single phase LXM28... servo drive 1 kW, 220 V, three phase
Shaft end	Keyed
Shaft diameter	0.87 in (22 mm)
Shaft length	1.77 in (45 mm)
Key width	0.31 in (8 mm)
Feedback type	20 bits single turn absolute encoder
Holding brake	Without

Mounting Support	Asian standard flange
Motor flange size	3.94 in (100 mm)
Electrical connection	Connector MIL
Torque constant	0.55 N.m/A 68 °F (20 °C)
Back emf constant	33 V/krpm 68 °F (20 °C)
Rotor inertia	2.4 kg.cm ²
Stator resistance	0.67 Ohm 68 °F (20 °C)
Stator inductance	4.2 mH 68 °F (20 °C)
Stator electrical time constant	6.27 ms 68 °F (20 °C)
Maximum radial force Fr	570 N 3000 rpm
Maximum axial force Fa	200 N
Brake pull-in power	10.4 W
Type of cooling	Natural convection
Length	6.04 in (153.5 mm)
Number of motor stacks	1
Centring collar diameter	3.74 in (95 mm)
Centring collar depth	0.28 in (7 mm)
Number of mounting holes	4
Mounting holes diameter	0.36 in (9.2 mm)
Circle diameter of the mounting holes	4.53 in (115 mm)
Distance shaft shoulder-flange	0.28 in (7 mm)
Net Weight	10.14 lb(US) (4.6 kg)

Environment

IP Degree of Protection	IP50 IM V3 IP65 IM B5, IM V1
Ambient Air Temperature for Operation	-4...104 °F (-20...40 °C)



Ordering and shipping details

Category	18281-LEXIUM 23/28 MOTORS
Discount Schedule	PC53
GTIN	3606480734021
Returnability	No
Country of origin	CN

Packing Units

Unit Type of Package 1	PCE
Number of Units in Package 1	1
Package 1 Height	7.13 in (18.1 cm)
Package 1 Width	9.06 in (23.0 cm)
Package 1 Length	14.17 in (36.0 cm)
Package 1 Weight	14.26 lb(US) (6.47 kg)

Offer Sustainability

Sustainable offer status	Green Premium product
California proposition 65	WARNING: This product can expose you to chemicals including: Lead and lead compounds, which is known to the State of California to cause cancer and birth defects or other reproductive harm. For more information go to www.P65Warnings.ca.gov
REACH Regulation	 REACH Declaration
REACH free of SVHC	Yes
EU RoHS Directive	Pro-active compliance (Product out of EU RoHS legal scope)
Mercury free	Yes
China RoHS Regulation	 China RoHS Declaration
RoHS exemption information	 Yes

Environmental Disclosure	Product Environmental Profile
Circularity Profile	End Of Life Information
WEEE	The product must be disposed on European Union markets following specific waste collection and never end up in rubbish bins.
PVC free	Yes

Dimensions

Dimensions of Motor

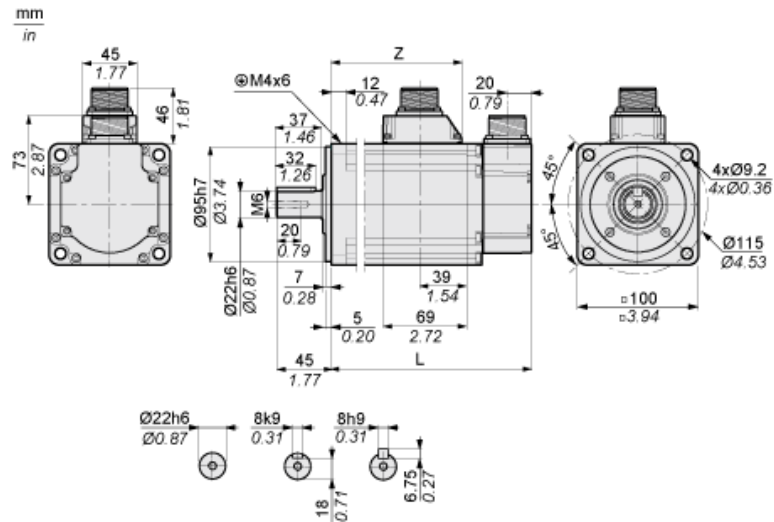

	mm	in.
L (without holding brake)	153.5	6.04
L (with holding brake)	180.5	7.11
Z	96	3.78

Torque/Speed Curves with 230 V Single/Three Phase Supply Voltage

Servo Motor with LXM28AU10●●● Servo Drive

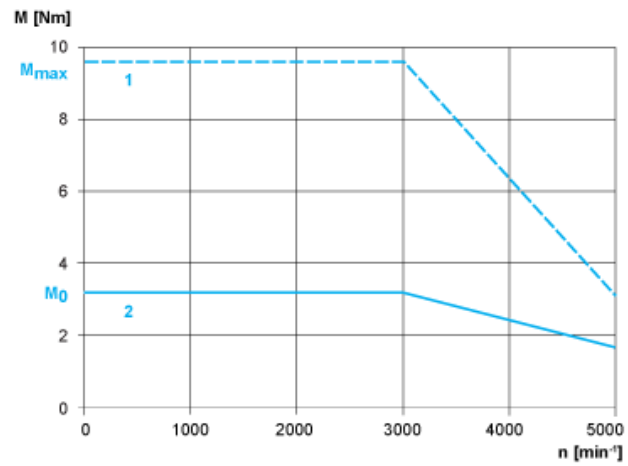

- 1 : Peak torque
- 2 : Continuous torque