

TM7BDO8TAB

Discrete I/O expansion block, Modicon TM7,
IP67, 8 DO, 24 V DC, 2 A, M8 connector



Main

Range of Product	Modicon TM7
Product or Component Type	Discrete I/O expansion block
Range Compatibility	Modicon LMC058 Modicon M258
Enclosure Material	Plastic
Bus type	TM7 bus
[Ue] rated operational voltage	24 V DC
Input/output number	8
Input/output number of block	8 O

Complementary

Discrete output number	8 <= 2 A transistor
Discrete output voltage	24 V
Discrete output voltage type	DC
Sensor power supply	24 V, 500 mA for all channels overload, short-circuit and reverse polarity protection
Electrical connection	1 male connector M12 - B coding - 4 ways bus IN 1 female connector M12 - B coding - 4 ways bus OUT 1 male connector M8 - 4 ways power IN 1 female connector M8 - 4 ways power OUT 1 female connector M8 - 3 ways actuator
Local signalling	For bus diagnostic 2 LEDs For sensor power supply diagnostics 2 LEDs
Operating position	Any position
Fixing Mode	By 2 screws
Net Weight	0.41 lb(US) (0.185 kg)

Environment

Standards	IEC 61131-2
Product Certifications	GOST-R[RETURN]C-tick[RETURN]ATEX II 3g EEx nA II T5[RETURN]cURus
Marking	CE
Ambient Air Temperature for Operation	14...140 °F (-10...60 °C)
Ambient Air Temperature for Storage	-13...185 °F (-25...85 °C)
Relative humidity	5...95 % without condensation or dripping water
Pollution degree	2 IEC 60664
IP degree of protection	IP67 conforming to IEC 61131-2
Operating altitude	0...6561.68 ft (0...2000 m)
Storage altitude	0.00...9842.52 ft (0...3000 m)
Vibration resistance	7.5 mm constant amplitude 2...8 Hz)IEC 60721-3-5 Class 5M3 2 gn constant acceleration 8...200 Hz)IEC 60721-3-5 Class 5M3 4 gn constant acceleration 200...500 Hz)IEC 60721-3-5 Class 5M3

The information provided in this documentation contains general descriptions and/or technical characteristics of the performance of the products contained herein. This documentation is not intended as a substitute for and is not to be used for determining suitability or reliability of these products for specific user applications. It is the duty of any such user or integrator to perform the appropriate and complete risk analysis, evaluation and testing of the products with respect to the relevant specific application or use thereof. Neither Schneider Electric Industries SAS nor any of its affiliates or subsidiaries shall be responsible or liable for misuse of the information contained herein.

Shock resistance	30 gn 11 ms IEC 60721-3-5 Class 5M3
Electromagnetic compatibility	Electrostatic discharge immunity test, 4 kV on contact IEC 61000-4-2 Electrostatic discharge immunity test, 8 kV in air IEC 61000-4-2 Susceptibility to electromagnetic fields, 1 V/m 2...2.7 GHz IEC 61000-4-3 Susceptibility to electromagnetic fields, 10 V/m 80...2000 MHz IEC 61000-4-3 Electrical fast transient/burst immunity test, 2 kV power supply IEC 61000-4-4 Electrical fast transient/burst immunity test, 1 kV input/output IEC 61000-4-4 Electrical fast transient/burst immunity test, 1 kV shielded cable IEC 61000-4-4 1.2/50 µs shock waves immunity test, 0.5 kV power supply (common mode) IEC 61000-4-5 1.2/50 µs shock waves immunity test, 1 kV power supply (differential mode) IEC 61000-4-5 1.2/50 µs shock waves immunity test, 0.5 kV unshielded links (common mode) IEC 61000-4-5 1.2/50 µs shock waves immunity test, 1 kV unshielded links (differential mode) IEC 61000-4-5 1.2/50 µs shock waves immunity test, 0.5 kV shielded links (common mode) IEC 61000-4-5 1.2/50 µs shock waves immunity test, 1 kV shielded links (differential mode) IEC 61000-4-5 Conducted RF disturbances IEC 61000-4-6 Conducted and radiated emissions CISPR 11

Ordering and shipping details

Category	22532-M258 PLC
Discount Schedule	PC12
GTIN	3595864093116
Returnability	No
Country of origin	AT

Packing Units

Unit Type of Package 1	PCE
Number of Units in Package 1	1
Package 1 Height	1.97 in (5.000 cm)
Package 1 Width	2.32 in (5.900 cm)
Package 1 Length	4.13 in (10.500 cm)
Package 1 Weight	7.20 oz (204.000 g)
Unit Type of Package 2	S02
Number of Units in Package 2	24
Package 2 Height	5.91 in (15.000 cm)
Package 2 Width	11.81 in (30.000 cm)
Package 2 Length	15.75 in (40.000 cm)
Package 2 Weight	11.51 lb(US) (5.222 kg)

Offer Sustainability

Sustainable offer status	Green Premium product
California proposition 65	WARNING: This product can expose you to chemicals including: Lead and lead compounds, which is known to the State of California to cause cancer and birth defects or other reproductive harm. For more information go to www.P65Warnings.ca.gov
REACH Regulation	REACH Declaration
EU RoHS Directive	Pro-active compliance (Product out of EU RoHS legal scope)
Toxic heavy metal free	Yes
Mercury free	Yes
China RoHS Regulation	China RoHS Declaration
RoHS exemption information	Yes
Environmental Disclosure	Product Environmental Profile
Circularity Profile	End Of Life Information
WEEE	The product must be disposed on European Union markets following specific waste collection and never end up in rubbish bins.
PVC free	Yes

Contractual warranty

Warranty	18 months
----------	-----------

Digital Output Block

Description

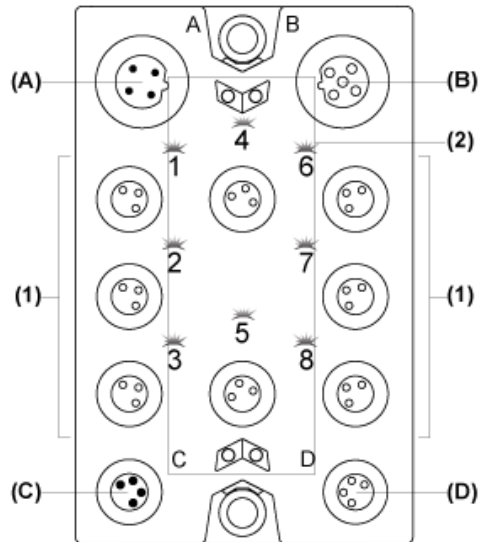

- (A) TM7 bus IN connector
- (B) TM7 bus OUT connector
- (C) 24 Vdc power IN connector
- (D) 24 Vdc power OUT connector
- (1) Output connectors
- (2) Status LEDs

Connector and Channel Assignments

Output connectors	Channel type	Channels
1	Output	Q0
2	Output	Q1
3	Output	Q2
4	Output	Q3
5	Output	Q4
6	Output	Q5
7	Output	Q6
8	Output	Q7

TM7 Block, Size 1

Dimensions

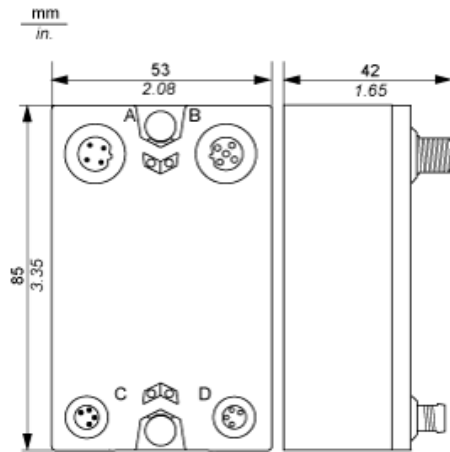

Spacing Requirements

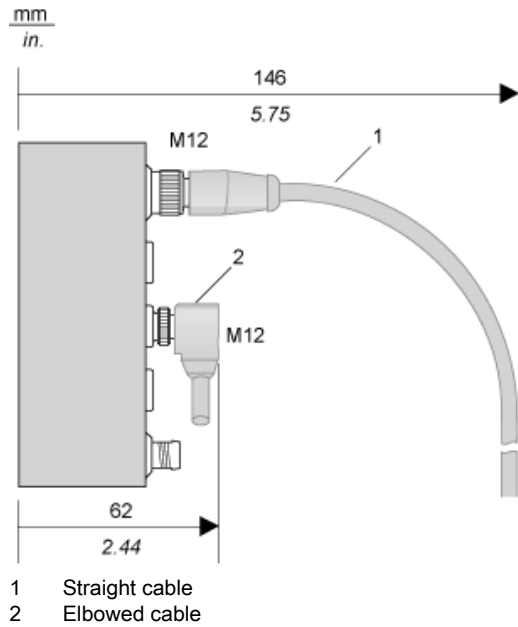

Installation Guidelines

TM7 Block on an Aluminium Frame

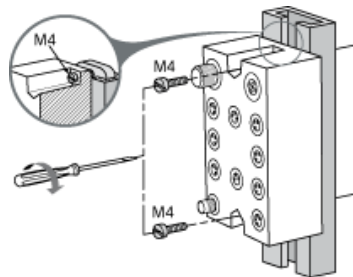

NOTE: Maximum torque to fasten the required M4 screws is 0.6 N.m (5.3 lbf-in).

TM7 Block on a DIN Rail

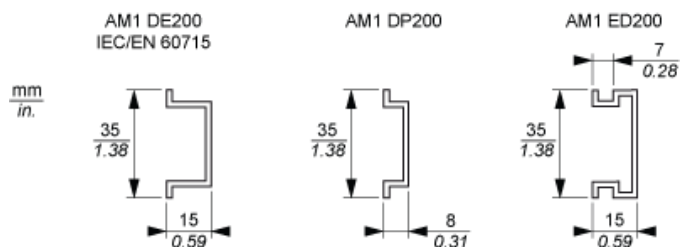

NOTE: Only size 1 (smallest) blocks can be installed on DIN rail with the TM7ACMP mounting plate.

TM7 Block Directly on the Machine

Drilling template of the block:

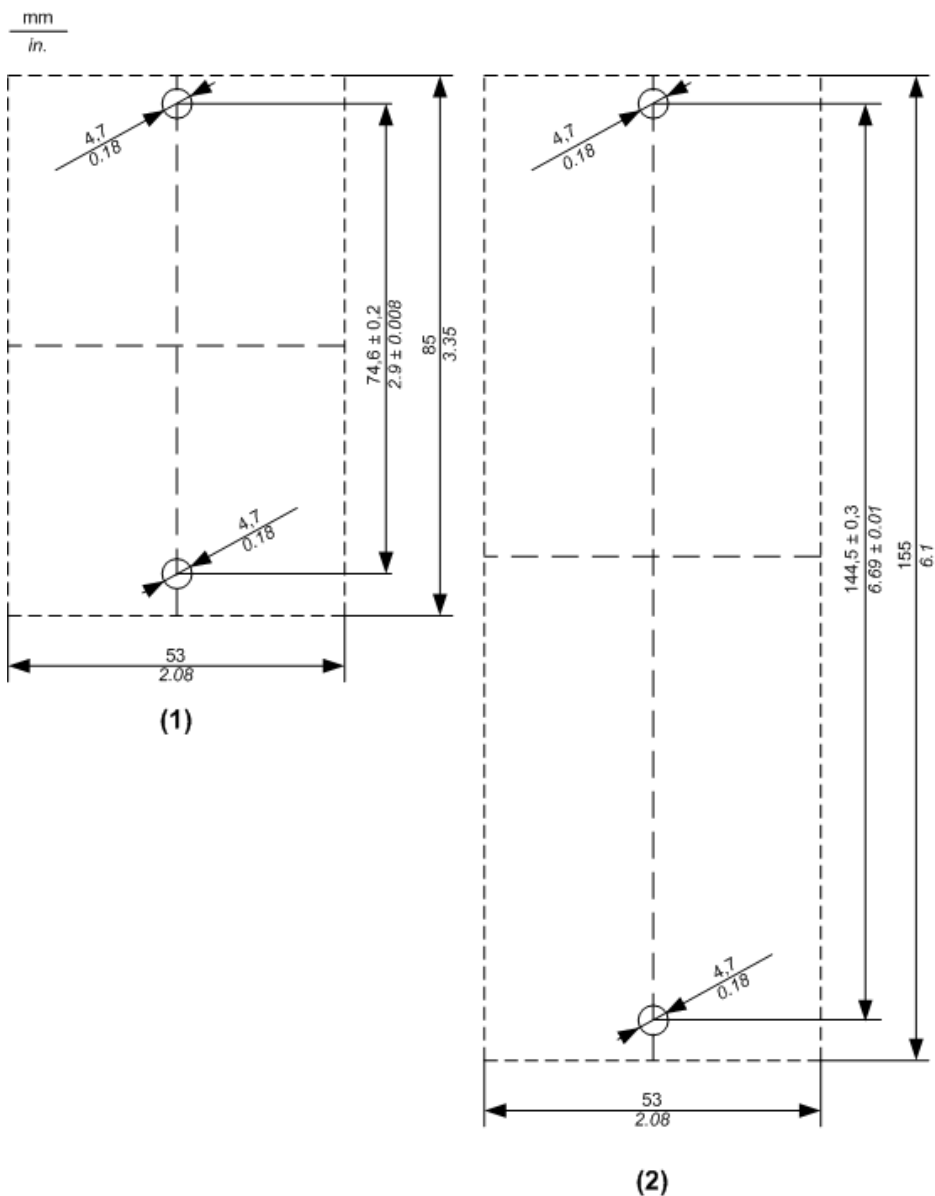

- (1) Size 1
- (2) Size 2

The thickness of the base plate should be taken into consideration when defining the screw length.

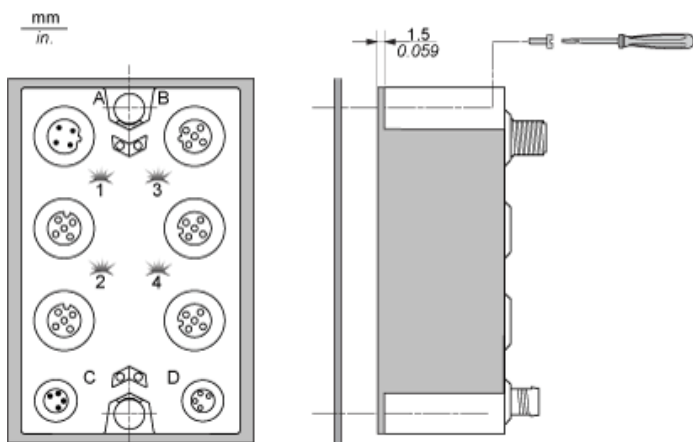

NOTE: Maximum torque to fasten the required M4 screws is 0.6 N.m (5.3 lbf-in).

Wiring Diagram

Pin Assignments for Output Connectors

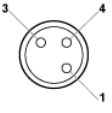
Connection	Pin	M8 Output
	1	24 Vdc actuator supply
3	0 Vdc	
4	DO: output signal	

Wiring the Power Supply

When you provide power to a TM7 I/O block using the 24 VDC Power OUT connector of the preceding I/O block, both blocks occupy the same 24 Vdc I/O power segment. However, if you connect an external isolated power supply to the 24 Vdc Power IN connector of a TM7 I/O block, you establish a new 24 Vdc I/O power segment beginning with that I/O block.

I/O block wired with one external 24 Vdc power supply:

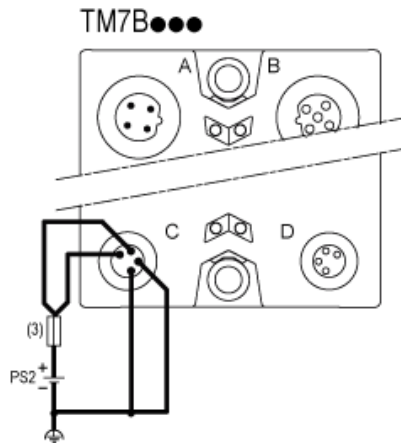

- (3) External fuse, Type T slow-blow, 8 A max., 250 V
- PS2 External isolated I/O power supply, 24 Vdc

Switching Inductive Load Characteristics

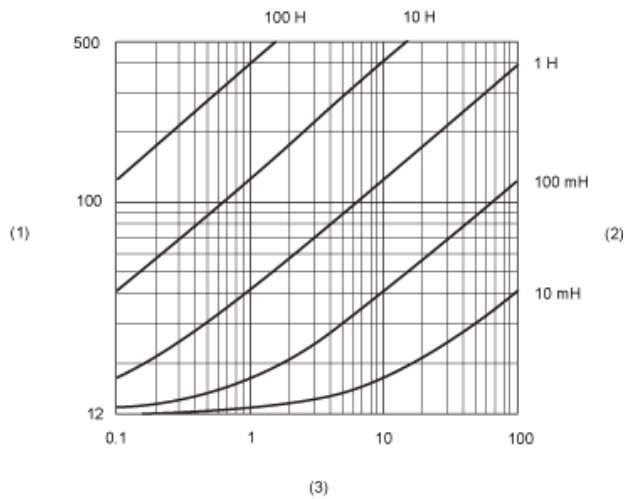

- (1) Load resistance in Ω
- (2) Load inductance in H
- (3) Max. operating cycles / second