

BMP1002R3NA2A

synchronous motor - BMP - 230 VAC - 1.5 kW - IP65 - IEC



Main

Product or Component Type	Synchronous motor
Device short name	BMP
Maximum mechanical speed	3600 rpm
Nominal output power	1100 W ATV32 1.1 kW 200 V single phase 1500 W ATV32 1.5 kW 200 V single phase 1100 W ATV320 1.1 kW 200 V single phase 1500 W ATV320 1.5 kW 200 V single phase
Nominal torque	30.98 lbf.in (3.5 N.m) ATV32 1.1 kW 200 V single phase[RETURN]42.22 lbf.in (4.77 N.m) ATV32 1.5 kW 200 V single phase[RETURN]30.98 lbf.in (3.5 N.m) ATV320 1.1 kW 200 V single phase[RETURN]42.22 lbf.in (4.77 N.m) ATV320 1.5 kW 200 V single phase
Nominal speed	3000 rpm ATV32 1.1 kW 200 V single phase[RETURN]3000 rpm ATV32 1.5 kW 200 V single phase[RETURN]3000 rpm ATV320 1.1 kW 200 V single phase[RETURN]3000 rpm ATV320 1.5 kW 200 V single phase
Product compatibility	Variable speed drive ATV32 1.1 kW 200 V single phase Variable speed drive ATV32 1.5 kW 200 V single phase Variable speed drive ATV320 1.1 kW 200...240 V single phase Variable speed drive ATV320 1.5 kW 200...240 V single phase
Shaft end	Keyed
IP Degree of Protection	IP65 standard IP67 with IP67 kit
Holding brake	Without
Mounting Support	International standard flange
Electrical Connection	Rotatable right-angled connector

Complementary

Range Compatibility	Altivar 32 Altivar Machine ATV320
[Us] rated supply voltage	230 V
Phase	Single phase
Maximum current Irms	10.4 A ATV32 1.1 kW 200 V single phase 12 A ATV32 1.5 kW 200 V single phase 10.4 A ATV320 1.1 kW 200 V single phase 12 A ATV320 1.5 kW 200 V single phase
Nominal operating frequency	250 Hz ATV32 1.1 kW 200 V single phase 250 Hz ATV32 1.5 kW 200 V single phase 250 Hz ATV320 1.1 kW 200 V single phase 250 Hz ATV320 1.5 kW 200 V single phase
Minimum operating frequency	25 Hz ATV32 1.1 kW 200 V single phase 25 Hz ATV32 1.5 kW 200 V single phase 25 Hz ATV320 1.1 kW 200 V single phase 25 Hz ATV320 1.5 kW 200 V single phase
Maximum operating frequency	300 Hz ATV32 1.1 kW 200 V single phase 300 Hz ATV32 1.5 kW 200 V single phase 300 Hz ATV320 1.1 kW 200 V single phase 300 Hz ATV320 1.5 kW 200 V single phase
Shaft diameter	0.75 in (19 mm)
Shaft length	1.57 in (40 mm)

The information provided in this documentation contains general descriptions and/or technical characteristics of the performance of the products contained herein. This documentation is not intended as a substitute for and is not to be used for determining suitability or reliability of these products for specific user applications. It is the duty of any such user or integrator to perform the appropriate and complete risk analysis, evaluation and testing of the products with respect to the relevant specific application or use thereof. Neither Schneider Electric Industries SAS nor any of its affiliates or subsidiaries shall be responsible or liable for misuse of the information contained herein.

Key width	0.24 in (6 mm)
Motor flange size	3.94 in (100 mm)
Torque constant	0.83 N.m/A 104 °F (40 °C)
Number of motor poles	5
Number of motor stacks	2
Rotor inertia	6.28 kg.cm ²
Stator resistance	0.53 Ohm 104 °F (40 °C)
Stator inductance	2.18 mH for q-axis winding 104 °F (40 °C) 1.89 mH for d-axis winding 104 °F (40 °C)
Maximum radial force Fr	990 N 1000 rpm 790 N 2000 rpm 690 N 3000 rpm 620 N 4000 rpm
Maximum axial force Fa	0.2 x Fr
Type of cooling	Natural convection
Length	6.32 in (160.6 mm)
Centring collar diameter	3.74 in (95 mm)
Centring collar depth	0.14 in (3.5 mm)
Number of mounting holes	4
Mounting holes diameter	0.35 in (9 mm)
Circle diameter of the mounting holes	4.53 in (115 mm)
Net Weight	10.85 lb(US) (4.92 kg)

Ordering and shipping details

Category	18282-LEXIUM 32 MOTORS
Discount Schedule	PC53
GTIN	3606480564451
Returnability	No
Country of origin	DE

Packing Units

Unit Type of Package 1	PCE
Number of Units in Package 1	1
Package 1 Height	8.66 in (22.0 cm)
Package 1 Width	7.68 in (19.5 cm)
Package 1 Length	15.55 in (39.5 cm)
Package 1 Weight	12.92 lb(US) (5.86 kg)
Unit Type of Package 2	P06
Number of Units in Package 2	6
Package 2 Height	30.31 in (77.0 cm)
Package 2 Width	31.50 in (80.0 cm)
Package 2 Length	23.62 in (60.0 cm)
Package 2 Weight	96.25 lb(US) (43.66 kg)

Offer Sustainability

California proposition 65	WARNING: This product can expose you to chemicals including: Lead and lead compounds, which is known to the State of California to cause cancer and birth defects or other reproductive harm. For more information go to www.P65Warnings.ca.gov
REACH Regulation	 REACH Declaration
EU RoHS Directive	Pro-active compliance (Product out of EU RoHS legal scope)
Mercury free	Yes
China RoHS Regulation	 China RoHS Declaration
RoHS exemption information	 Yes
WEEE	The product must be disposed on European Union markets following specific waste collection and never end up in rubbish bins.
PVC free	Yes

Contractual warranty

Warranty	18 months
----------	-----------

Dimensions

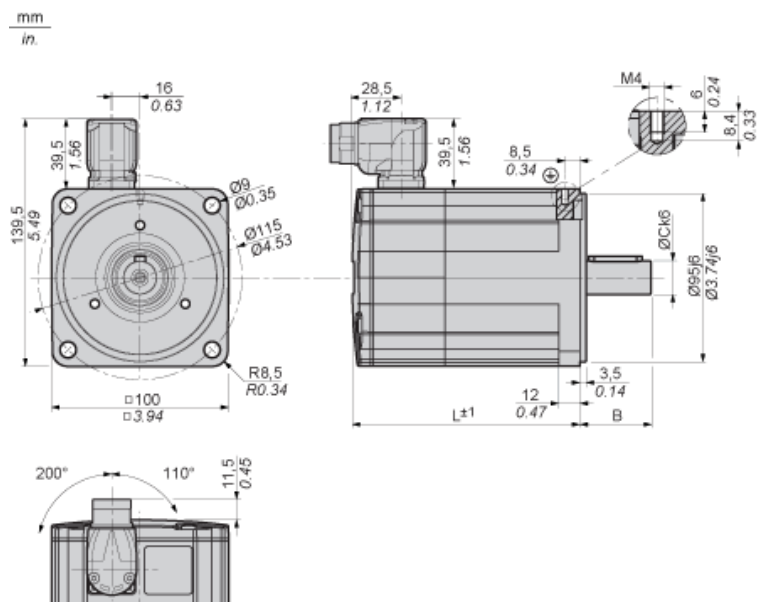

Parallel Key According to DIN 6885 A

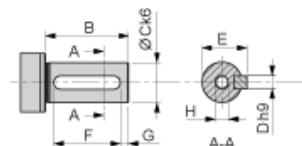

Female Thread of Shaft According to DIN 332-D

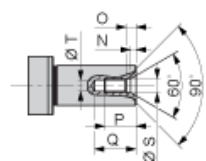

L	mm	160.6
in.	6.32	
B	mm	40
in.	1.57	
C	mm	19
in.	0.75	
D	mm	6
in.	0.24	
E	mm	21.5
in.	0.85	
F	mm	30
in.	1.18	
G	mm	5
in.	0.20	

H		M6
N	mm	2.8
in.	0.11	
O	mm	5
in.	0.20	
P	mm	16
in.	0.63	
Q	mm	21
in.	0.83	
S	mm	6.4
in.	0.25	
T	mm	5
in.	0.20	

Performance curves

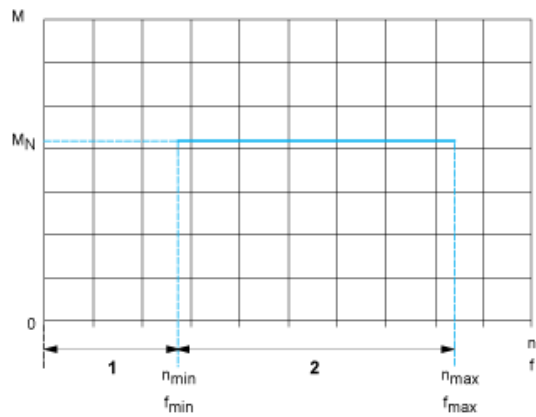

- M : Torque in Nm
- n : Speed in rpm
- f : frequency in Hz
- 1 : Only permissible during acceleration and deceleration phases.
- 2 : Continuous operation with the default values from the configuration file.