

ORDERING INFORMATION

Order code: 62936
 Description: BHPS0070/QUADTAP/C/HX/H/K/STD
 UPC: 69549629363



SPECIFICATIONS

Ballast type: Magnetic high pressure sodium
 Ballast style: Core and coil
 Circuit type: HX-HPF
 ANSI code: S62
 Input voltage (V): 120/208/240/277
 Input frequency (Hz): 60
 Line volt regulation: 5 %
 Line watt regulation: Within trapezoid
 Insulation class: H (180)

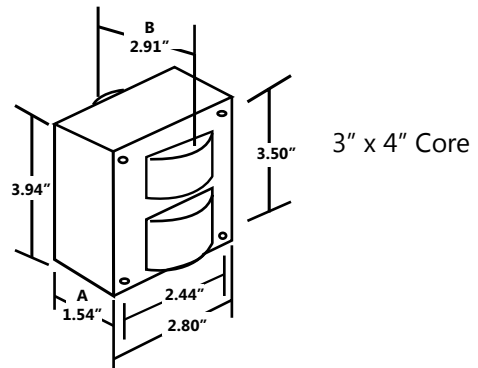

Input voltage (V)	Operating current (A)	Open circuit current (A)	Starting current (A)	Rated lamp watts (W)	Input watts (W)	OCV (V)	Dropout voltage (V)	UL 1029 code	Fuse rating (A)	Input current (A)	Power factor	Starting temperature
120	0.82	1.35	0.78	70	93	124	79	A	5	0.55-0.85	0.90	-40°F / -40°C
208	0.47	0.79	0.52	70	93	124	141	A	3	0.30-0.50	0.90	-40°F / -40°C
240	0.41	0.68	0.40	70	93	124	160	A	3	0.25-0.45	0.90	-40°F / -40°C
277	0.35	0.60	0.36	70	93	124	193	A	2	0.30-0.35	0.90	-40°F / -40°C

HIGH POTENTIAL TEST (V)

1 minute:	2 000
2 seconds:	2 500
OCV test:	122 - 124
Short circuit:	2.10 - 2.15

BALLAST DIMENSIONS

Dimension A:	1.54"
Dimension B:	2.91"
Lead lengths:	12" - 14"
Weight (lbs) :	4.74

WIRING DIAGRAM

Ground ballast core

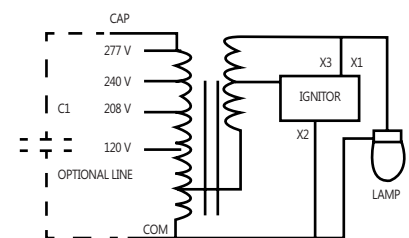

BRACKET

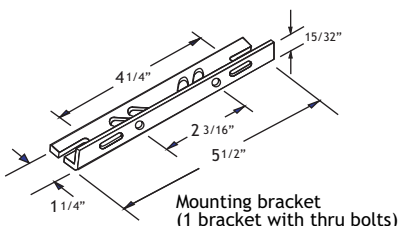

CAPACITOR

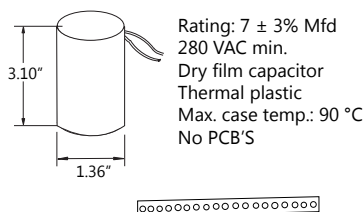

IGNITOR

