

BRS2851A600

2-phase stepper motor - 2.96 N.m - shaft Ø14 mm - L=60mm - without brake - 6.3A

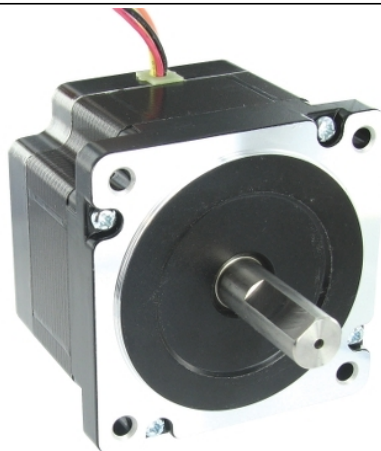

Main

Range compatibility	Lexium SD2
Product or component type	Motion control motor
Device short name	BRS2
Motor type	2-phase stepper motor

Complementary

Maximum mechanical speed	1800 rpm
Supply voltage limits	12...48 V DC
Mounting support	Flange
Motor flange size	3.39 in (86 mm)
Length	2.36 in (60 mm)
Number of motor stacks	1
Centring collar diameter	2.87 in (73 mm)
Centring collar depth	0.08 in (2 mm)
Number of mounting holes	4
Mounting holes diameter	0.22 in (5.5 mm)
Circle diameter of the mounting holes	3.87 in (98.4 mm)
Electrical connection	Flying lead
Holding brake	Without
Shaft end	Smooth shaft
Second shaft	Without second shaft end
Shaft diameter	0.55 in (14 mm)
Shaft length	1.38 in (35 mm)
Holding torque	26.20 lbf.in (2.96 N.m)
Rotor inertia	1 kg.cm ²
Resolution	200 steps number of full steps per revolution 1.8 ° step angle
Line Rated Current	6.3 A
Resistance	0.25 Ohm (winding)

Environment

Ambient air temperature for operation	-13...104 °F (-25...40 °C)
Ambient air temperature for storage	-13...158 °F (-25...70 °C)
Operating altitude	<= 3280.84 ft (1000 m) without power derating
Relative humidity	15...85 % without condensation
IP degree of protection	IP20 conforming to IEC/EN 60034-1
Temperature class	B winding conforming to IEC/EN 60034-1

Dimensions

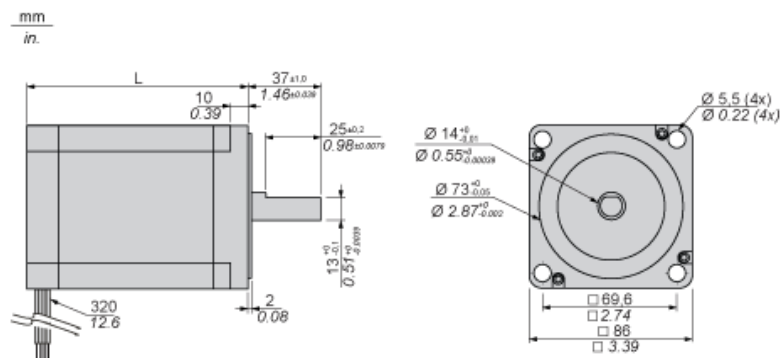

Dimensions in mm

L
60

Dimensions in in.

L
2.36

Torque Characteristics

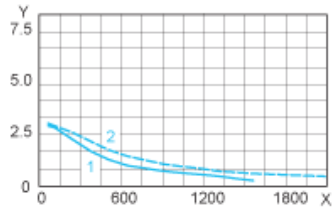

X : Speed of rotation in rpm
Y : Torque in Nm
1 : 24 VDC
2 : 48 VDC